





VIM is a global marketing and manufacturer of Fastening systems .  
Our production ranges include Nailers, Aftermarket Nailer Parts,  
collated screwdrivers and all kinds of collated fasteners.



Since Year of 2000, our goal has been simple: We are better than our words.  
VIM stands for innovation, quality and customer relationships.  
Generating hundreds of daily interactions with customers, creating the basis for the ongoing development of  
new products and services.

Above and beyond that legendary, gray body and black cap, instantly being recognized all around the world,  
VIM is a brand featuring a full range of high performance tools and spare parts.  
Our full line of professional grade speciality products to perform specific tasks fast and precisely.

At worksites and workplaces all around the globe, VIM's fasteners and tools contribute to the productivity and  
success of hardworking professionals.  
We create fastening systems that provide exceptional results and let you take pride in a job well done.

## Our Service



Punctual delivery



Operations & Maintenance



Providing a complete inspection report

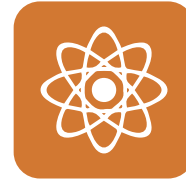

Energy



Communication



Strongest & Sustainable package



Always care your need



Careful inspection



Searching new items for you



Package design service



News



Expanding new Market



Cost reduction



Help

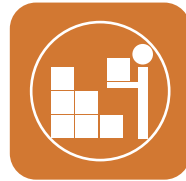

Storage



Always listen to you



Ambition



Innovation



Logistic



Quality assurance



Help you making money



Info provides



Experiment



Royalty



## Nailers

- 12-13 Concrete nailer
- 13 Positive placement metal connector nailer
- 14-17 Framing nailer
  - 17 Anchoring nailer
- 18-28 Coil nailer - 0 degree/ Angled/ Cap
- 29-33 Pin nailer
- 34-38 Finishing nailer
  - 39 Brad nailer
  - 40 T-nailer
- 41-44 Corrugated nailer
  - 44 Roofing nailer
  - 45 V-nailer
- 46-50 Palm nailer
  - 51 Insulation nailer
  - 52 Frame wedge nailer

## Manual Point Driver

- 52 Manual Point Driver

## Gas fuel cell pack

- 53 Gas fuel cell pack

## Staplers

- 54-61 Upholstery stapler
- 61-62 Polymer stapler
- 62-66 Wire staplers - Fine/Medium
- 67-70 Pneumatic stapler
  - 71 Cap stapler
  - 72 Roofing stapler
  - 72 Flooring stapler
- 73-79 Carton stapler
- 80-88 Bottomer
  - 89 Mattress stapler
- 90-92 Manual staple gun tracker
- 93 Stitcher

## Pliers

- 94-104 Hog ring plier - Pneumatic/Battery
- 105-109 Stapling plier
  - 110 D-ring plier
  - 111 Bedding plier

## Manual pliers

- 112 Clinching plier
- 113 Omega plier
- 113 C-ring plier
- 114 Stapling plier

## Other power source

- 115-116 Battery screwdriver
- 117 Power actuated tool
- 118 Refillable spray can



**Accessories**

- 119 Coupler
- 120 Carton supporter

**Air compressors** 122-130

**Air hose reel** 131-136

**Free service**

- 137 Free Artwork & Package Design are available

**Drive pin** 138-139

**Fasteners**

- 140 **Rings**
  - C-Ring
  - D-Ring
  - Omega Ring

- 141 **Screws**
  - Collated screw
  - Chipboard screw
  - Drywall screw
  - Self drilling screw
  - Tapping screw

- 142-153 **Nails**
  - Pin nail
  - Brad
  - T nail
  - Flooring cleat
  - Strip nail
  - Coil nail
  - Corrugated nail
  - Concrete nail

- 154-155 **Staples**
  - U staple
  - Power crown staple
  - Divergent point staple
  - Cable staple
  - Aluminum staple

156 **Carton closing**

157 **Cartridge wedge**

**V nail**

**Frame wedge**



158-159 **Clinching clip**



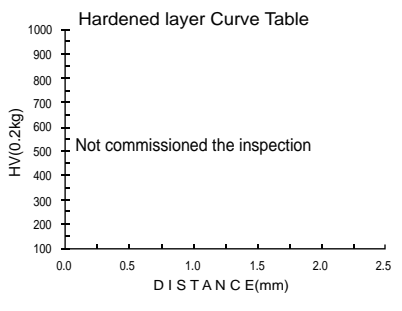

# Material Certificate For Driver Assembly

Made in Germany				 DEUTSCHE EDELSTAHLWERKE Providing special steel solutions															
ABNAHMEPRÜFZEUGNIS INSPECTION CERTIFICATE ACCORDING TO CERTIFICAT DE RECEPTION				EN 10204 3.1		zertifiziert nach ISO / TS 18949 ISO 14001 QS 9000 DGR 97/23/EG PED 97/23/EC LRQA GmbH Kenn-Nr.0525										ISO / IEC 17025		Prüf - Nr. 47688 / Seite Page / Page 1 / 1	
Hereteller Manufacteur Producteur DEUTSCHE EDELSTAHLWERKE GMBH Postf. 4263 / D-58042 HAGEN				Uns. Auftr.-Nr. Order - No. Notre Com. No. 1189488		Werkstoff Quelly Nuance 1.2249 2249				Eraegnlform Product Product Blankstahl in Staeben GKZ-geglueht,gezogen gezogen									
Besteller Customer Client VIM INTERNATIONAL ENTERPRISE CO.,LTD.				Bestell. Nr. Order-No. EC 1572		No. 21, Sec. 1, Ljouchuan E. Rd., South District, Taichung City 402, Taiwan R.O.C.				STRANGGUSS CONTINUOUS CASTING COULEE CONTINUE				Anforderungen Requirements Preecrodors de controlo KUNDENBESTELLUNG					
Schmelzen-Nr. Cast No. / Coulée No. 217890		Proben-Nr. Test N. / Eprouv.N. 793072		Los-Nr. Lot No. / Lot No. 793072		Pos. Item / Poste 001		Abmessung mm Dimensions / Dimensions 12,00 RD		Stückzahl Quantity / Nombre 3202		Gewicht KG Weight / Masse 3202		Stempel des Abnahmebeauftragten WA					
Pchmelzen-Nr. Cast No/Coulée No. 217890		% C 0,470	% SI 1,43	% MN 0,64	% P 0,010	% S 0,003	% CR 1,38	% CU 0,13	% AL 0,021	% V 0,080	% TI 0,0026	% SN 0,0096							
Proben-Nr. Test No. Eprouv.N. 793072	Ref. Zust. L	Probenabm. Samp.Dim. Dim.d'epr L	Problg. Spec.Pos. Pos.d'epr L	Zugversuch Tensile test / Essai de traction RM MPa 826 Z % 51				Kerbschlagversuch Impact test / Essai de resilience 815 53				Härteprüfung Hardness Dureté							
PRUEFUNG AUF WERKSTOFFIDENTITAET DURCHGEF.: OB.																			
Das Zeugnis wurde maschinell erstellt und ist gemäß EN 10204 ohne Unterschrift rechtsverbindlich. This certificate was generated by data system,acc. to EN 10204, it need not to be signed for validity. Ce certificat a été établi sur système informatique et est valable selon EN 10204 sans signature.												Datum : 17.02.2010 Tel : 02331/398-5326 Fax : 02331/398-5366 Hesse (Abnahmebeauftragter)							

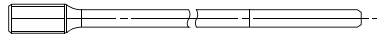
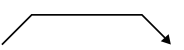
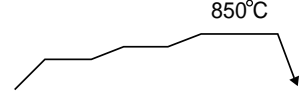
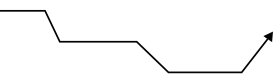
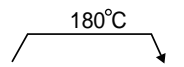

Quality inspection report form			ManagementNo.	
Customer Name	VIM INTERNATIONAL ENTERPRISE CO.,LTD.		Heat treatment name	Vacuum Whole hardening
Product Name & size	1857		Hardness values	HRC56±1
			Carburizing depth	- mm
	Cryogenic/Ultracold		-	
Quantity/weight	1000 /pcs /kg		Heat treatment after the completion of plus do	-
Date of Receipt	2012/3/23		Adjust the straightness	- pcs
Material	S7	Specify the delivery at the	Back to the company	
Material total weight	15.6 /kg			
Test results				
Customer commissioned pieces				
external In kind	Internal Cutting inlay Test piece			
Measure Hardness				
HRC				
1	55.5			
2	55.8			
3	55.6			
4	-			
5	-			
Average	55.6			
Delect Person	Shen-de,Yan			
<div style="border: 1px solid black; padding: 10px; text-align: center;">Not commissioned the inspection</div>			<div style="border: 1px solid black; padding: 10px; text-align: center;">Not commissioned the inspection</div>	
Corrosion Organization picture External(400x)			Corrosion Organization picture center(400x)	
 <b>VIM INTERNATIONAL ENTERPRISE CO., LTD.</b> No. 21, Sec. 1, Liouchuan E. Rd., South District, Taichung City 402, Taiwan R.O.C. Tel: 886-4-2373-0103 / Fax: 886-4-2373-0207			Manager	Be In Charge Of
			Yu Kai Liao	Shen-de, Yan
			Detect Personnel	

VIM INTERNATIONAL ENTERPRISE CO.,LTD. Heat Treatment Inspection Report				
Receive Date	2012104102	Delivery Date	2012104106	Sketch of Driver blade
Customer		ITEM	CN55	
Materials	Steel 2249	Quantity	307	
standard				
Case hardening	HRC:55-57	Care harding		
Carburized depth		Nitrogenation depth		
Heat treatment				
stress relieving		quenching		
				
sub-zero treatment		tempering		
				
Q.C report				
Case hardening	HRC:55-57			
Care liarding				
Carburized depth		Nitrogenation depth		
structure				
Result				Inspector
				









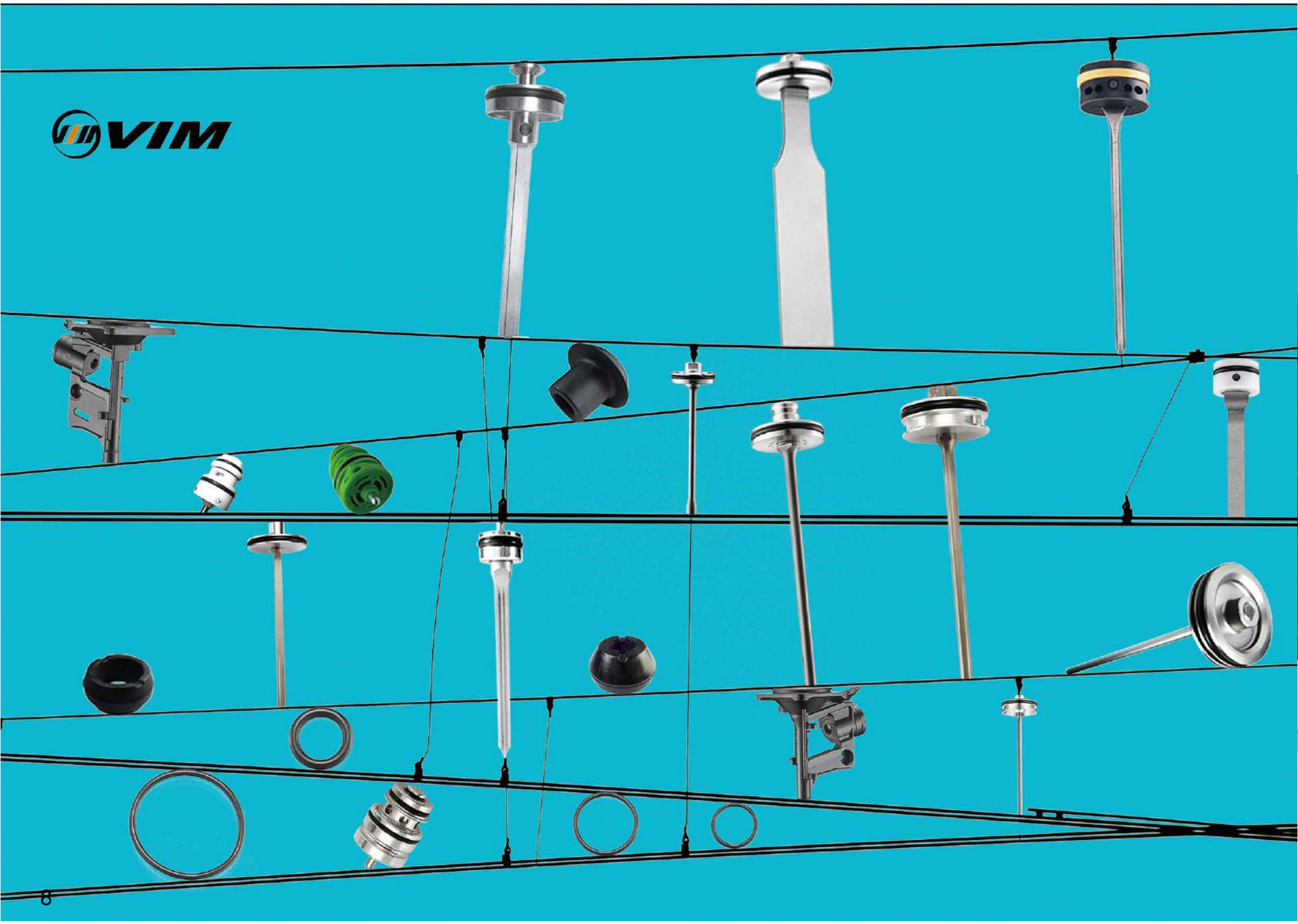





Heating the greatest driver assembly



***WE BUILD THE CITY***



# 12 GA. 0° Straight Collated Concrete Nailer

Model No: C3040

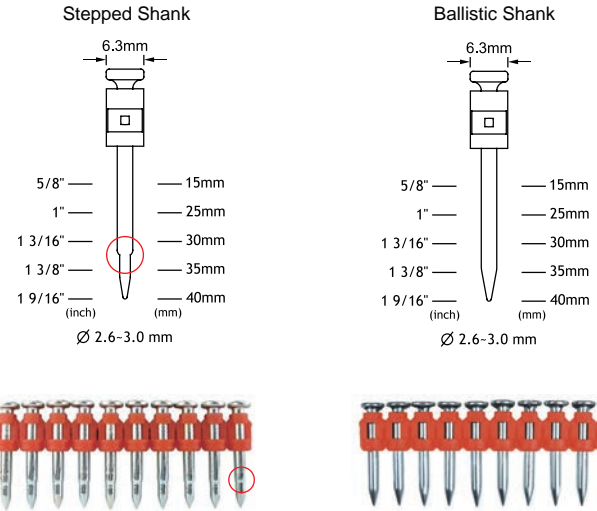

■ Heat-Treated Plastic Collated Concrete Nails For C3040

Model No	C3040
L x W x H	380x130x330 mm
Weight	2.6 kgs
Gauge	12 GA
Shank Dia	2.6~3.0 mm
Fastener Range	15~40 mm
Capacity	35 pcs
Working Pressure	80~125 psi
Power	88 J

### APPLICATION

- Reinforce construction
- Tectonic floor
- Drywall and partition
- Steel to concrete
- Steel to steel

### FEATURES

- Powerful
- Rubber grip for comfort
- Well-balanced
- Light weight only 2.6 kgs
- No licensing required
- No electric cord
- Battery pack required



Reinforce Construction



## 12 GA. 0° Heavy Duty Concrete Nailer

Model No: C3065

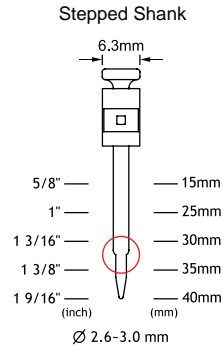

## Positive Placement Metal Connector Nailer

Model No: PM4165

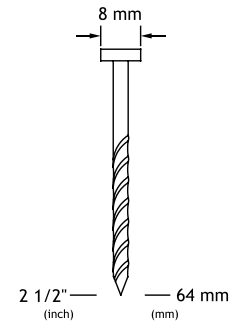

Model No	C3065
L x W x H	370x130x330 mm
Weight	5.2 kgs
Gauge	12 GA
Shank Dia	2.6~3.0 mm
Fastener Range	15~65 mm
Capacity	38 pcs
Working Pressure	80~125 psi

### APPLICATION

- Reinforce construction
- Tectonic floor
- Drywall and partition
- Steel to concrete
- Steel to steel
- Wood to concrete

### FEATURES

- More powerful than gas concrete pinner
- Use same pins with gas nailer
- 360 degree exhaust deflector
- Adjustable safety for pin depth control
- Extra handle bar for easy operation
- Single and consecutive fire

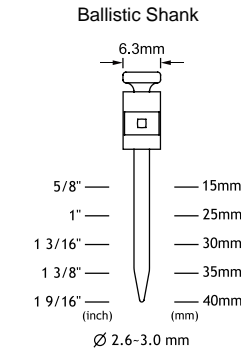

Model No	PM4165
L x W x H	330x100x315 mm
Weight	2.3 kgs
Fastener Range	USA:3.1-4.1 mm x 1-1/2",2",2-1/2"
	EURO:3.1-4.1 mm x 40,50,60 mm
Nail Capacity	25 nails
Operating Pressure	70~120 psi

### APPLICATION

- Metal connector strips
- Joist hangers
- Framing
- Trusses
- Decking

### FEATURES

- 360 Degree adjustable deflector
- Rear loading
- Positive nail setting design
- In line magazine, balance and convenient
- Powerful to shoot 65mm long nails
- Patented air sequential system
- Patented air control single firing, no double shooting



## Framing Nailer

Model No: 21130FNC

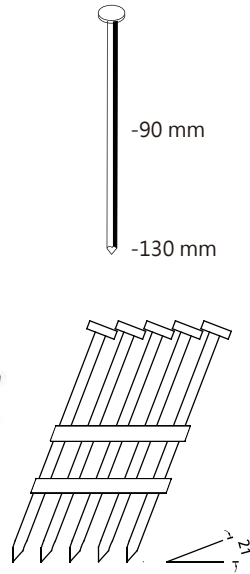

Model No	21130FNC
L x W x H	452x188x588 mm
Weight	5.4 kgs
Nail Shank Dia	3.33~4.19 mm
Length	90~130 mm
Nail Angle	21°
Capacity	50 pcs
Operating Pressure	85~120 psi

### APPLICATION

- Packaging, crating, pallets
- Industrial, Pre-Fabricated housing

### FEATURES

- 360 degree adjustable exhaust deflector with noise reducer
- Depth-Of drive adjustable
- Aggressive Toe-Nailing teeth for Slip-Free grip when fastening
- Sofa rubber grip for added comfort and less fatigue
- Well balanced
- Sequential fire trigger
- Dry-Fire lock

## Framing Nailer

Model No: 2190FNCA

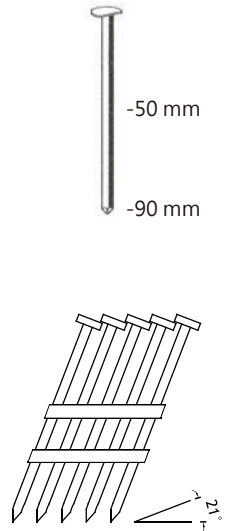

Model No	2190FNCA
L x W x H	442x124x331 mm
Weight	3.7 kgs
Nail Shank Dia	2.87~4.1 mm
Length	50~90 mm
Nail Angle	21°
Capacity	60 pcs
Operating Pressure	70~100 psi

### APPLICATION

- Roofing, carpentry
- Framing, joiner
- Door, window, trimming, picture, frames, building components
- Packaging, crating, pallets
- Industrial, Pre-Fabricated housing

### FEATURES

- Aggressive Toe-Nailing teeth for Slip-Free grip when fastening
- Depth-of drive adjustment
- Special design No-Mar rubber pad
- Dedicated sequential or bumper or Anti-Double fire Trigger - For enhanced safety and durability
- Optional hanger





## Framing Nailer

Model No: 21100FNCA



Model No	21100FNCA
L x W x H	49 5x117x376 mm
Weight	3.64 kgs
Nail Shank Dia	2.87~4.1 mm
Length	50~100 mm
Nail Angle	21°
Capacity	60 pcs
Operating Pressure	70~100 psi

### APPLICATION

- Roofing, carpentry
- Framing, joiner
- Door, window, trimming, picture, frames, building components
- Packaging, crating, pallets
- Industrial, Pre-Fabricated housing

### FEATURES

- 360 degree adjustable exhaust deflector
- Depth-of-drive adjustment
- Agressive toe-nailing teeth for slip-free grip when fastening
- Removable no-mar rubber tip
- Dedicated sequential or bump fire trigger -for enhanced safety and durability
- Top load magazine
- Dry-fire lock

## Framing Nailer

Model No: 3490FNCA



Model No	349 0FNCA
L x W x H	442x124x331 mm
Weight	3.7 kgs
Nail Shank Dia	2.87~4.1 mm
Length	50~9 0 mm
Nail Angle	34°
Capacity	60 pcs
Operating Pressure	70~100 psi

### APPLICATION

- Roofing, carpentry
- Framing, joiner
- Door, window, trimming, picture, frames, building components
- Packaging, crating, pallets
- Industrial, Pre-Fabricated housing

### FEATURES

- Agressive Toe-Nailing teeth for Slip-Free grip when fastening
- Depth-of drive adjustment
- Special design No-Mar rubber pad
- Dedicated sequential or bumper or Anti-Double fire Trigger - For enhanced safety and durability
- Optional hanger



## Framing Nailer

Model No: 3490FNCA2

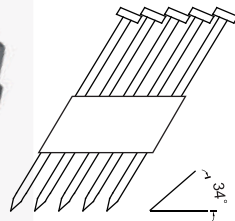

Model No	3490FNCA2
L x W x H	465x155x370 mm
Weight	3.65 kgs
Nail Shank Dia	2.87~4.1 mm
Length	50~90 mm
Nail Angle	34°
Capacity	75~90 pcs
Operating Pressure	70~100 psi

### APPLICATION

- Roofing, carpentry
- Framing, joiner
- Door, window, trimming, picture, frames, building components
- Packaging, crating, pallets
- Industrial, Pre-Fabricated housing

### FEATURES

- 360 degree adjustable air deflector
- Depth-of-drive adjustment
- Toe-nailing teeth for slip-free grip
- No-mar rubber pad
- Sequential fire trigger available
- Dry-fire lock

## Framing Nailer

Model No: 34100FNCA

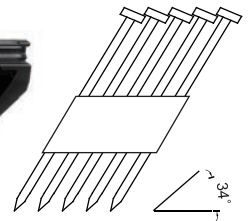
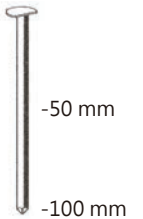

Model No	34100FNCA
L x W x H	354x153x443 mm
Weight	3.43 kgs
Nail Shank Dia	2.87~3.3 mm
Length	50~100 mm
Nail Angle	34°
Capacity	75 pcs
Operating Pressure	85~120 psi

### APPLICATION

- Roofing, carpentry, framing, joiner
- Door, window, trimming, picture, frames, building components
- Packaging, crating, pallets
- Industrial, Pre-Fabricated housing

### FEATURES

- Depth-of-drive adjustment
- Aggressive toe-nailing teeth for slip-free grip when fastening
- Special design no-mar rubber pad for better working performance
- Dedicated sequential or bump fire trigger -for enhanced safety and durability
- Light weight and well balance
- Optional hanger



Special no-mar rubber pad



## Framing Nailer

Model No: 34100FNCA2

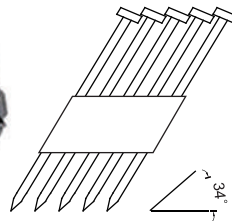
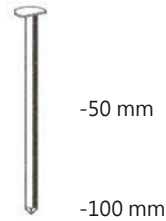

## Anchoring Nailer

Model No: AN65

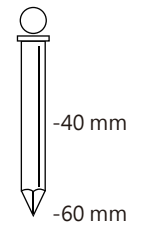

Model No	34100FNCA2
L x W x H	495x117x376 mm
Weight	3.64 kgs
Nail Shank Dia	2.87~4.1 mm
Length	50~100 mm
Nail Angle	34°
Capacity	60 pcs
Operating Pressure	70~100 psi

### APPLICATION

- Roofing, carpentry
- Framing, joiner
- Door, window, trimming, picture, frames, building components
- Packaging, crating, pallets
- Industrial, Pre-Fabricated housing

### FEATURES

- 360 degree adjustable exhaust deflector
- Depth-of-drive adjustment
- Aggressive toe-nailing teeth for slip-free grip when fastening
- Removable no-mar rubber tip
- Dedicated sequential or bump fire trigger -for enhanced safety and durability
- Top load magazine
- Dry-fire lock

Model No	AN65
L x W x H	320x86x290 mm
Weight	2.5 kgs
Nail Shank Dia	3.3, 3.8, 4.1 mm
Length	40, 50, 60 mm
Capacity	25 pcs

### APPLICATION

- Joist hangers
- Metal connectors

### FEATURES

- Nail setting design for exact nails drive into metal connector holes
- Complete single fire for safety purpose
- Drives both 34 degree paper and plastic collated strip nails with either heat-treated or non heat-treated
- Directional air exhaust

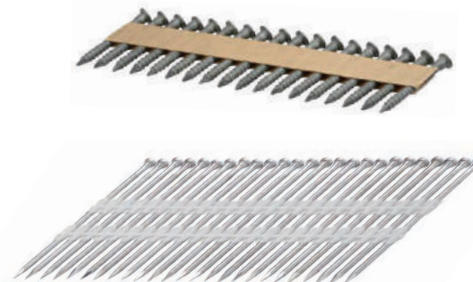

## 16° Coil Nailer

Model No: CN130WPB

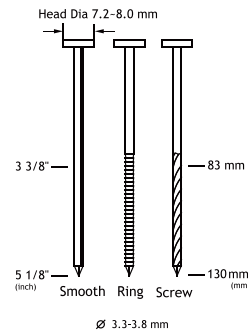

## 16° Wire Collated Coil Nailer

Model No: CN100WPB

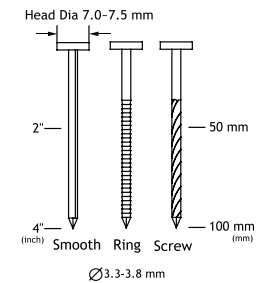

Model No	CN130WPB	CN100WPB
L x W x H	380x113x480 mm	380x113x420 mm
Weight	5.5 kgs	5 kgs
Head Dia	7.2~8.0 mm	7.0~7.5 mm
Nail Shank	3.3~3.8 mm	3.3~3.8 mm
Fastener Range	83~130 mm	50~100 mm
Magazine Type	Flat type	Flat type
Capacity	200~300 nails	200~300 nails
Operating Pressure	100~120 psi	100~120 psi

### APPLICATION

- Construction work (ex:siding, roofing and sheathing)
- Wooden cases
- Pallets
- Wooden furniture
- Wooden sashes and other wood products
- Reinforce construction
- Floor
- Drywall and partition
- Steel to steel
- Steel to concrete

### FEATURES

- 360 degree exhaust deflector allows exhaust of air in any direction
- Depth of drive adjustment to countersink or flush drive nails
- Lightweight design prevents arm fatigue for user
- Drives wire and plastic sheet collated nails
- Aluminium Alloy Housing
- Side loading magazine
- Single fire and consecutive driving of nails for CN100WPB

### FEATURES OF CN130WPB & CN100WPB

- A : Gun body with handle
- B : Single or sequential firing trigger
- C : Nail depth adjustable dial



A



B



C



## 15° Wire Collated Coil Nailer

Model No: CN100M

■ All parts compatible with MAX@CN100

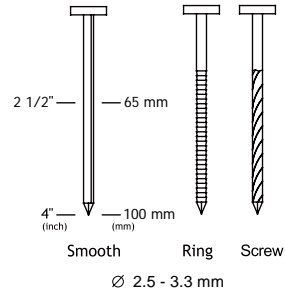

## Heavy Duty Coil Nailer

Model No: CN90AC

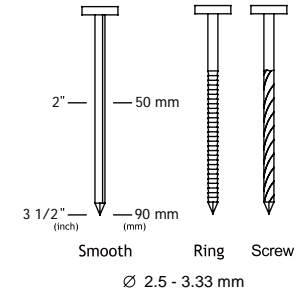

Model No	CN100M
L x W x H	338x156x417 mm
Weight	5.5 kgs
Angle	15°
Fastener Range	65~100 mm
Shank Type	Smooth / Ring / Screw
Capacity	200~300 pcs
Working Pressure	70~120 psi

### APPLICATION

- Wooden pallet, drums and boxes construction
- Crating
- Wooden fencing
- General construction
- Siding
- Decking, sheathing and framing

### FEATURES

- Cushioned rubber grip and Ergonomic frame design provide comfort and balance during operation
- Tough nylon, fast and easy loading magazine
- Metal nail tray, most durable in the industry
- Dust cover blocks nails or wire chips
- Body Protector on enduring frame

Model No	CN90AC
L x W x H	300x98x370 mm
Weight	3.44 kgs
Angle	15°
Fastener Range	50~90 mm
Shank Type	Smooth / Ring / Screw
Capacity	300 pcs
Working Pressure	80~120 psi

### APPLICATION

- Packaging, crating, pallets
- Siding, sheathing, paneling, fencing
- Industrial, pre-fabricated housing

### FEATURES

- Ergonomic design, well balanced
- Powerful, rapid nailing performance



## Heavy Duty Coil Nailer

Model No: CN90BC

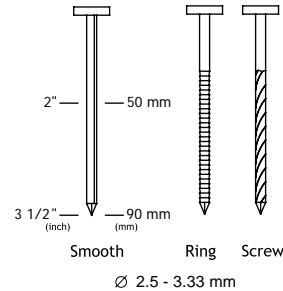

## Heavy Duty Coil Nailer

Model No: CN90C

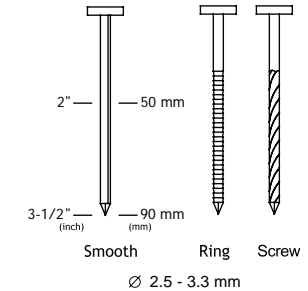

Model No	CN90BC
L x W x H	345x130x370 mm
Weight	3.71 kgs
Angle	15°
Fastener Range	50~90 mm
Shank Type	Smooth / Ring / Screw
Capacity	300 pcs
Working Pressure	80~120 psi

### APPLICATION

- Packaging, crating, pallets
- Siding, sheathing, paneling, fencing
- Industrial, pre-fabricated housing

### FEATURES

- Ergonomic design, well balanced
- Powerful, rapid nailing performance

Model No	CN90C
L x W x H	300x130x380 mm
Weight	3.7 kgs
Angle	15°
Nail Shank Dia	2.5~3.3 mm
Fastener Range	50~90 mm
Magazine Type	Flat type
Housing Material	Aluminum Alloy
Magazine Loading	Side loading magazine
Trigger Type	Consecutive driving of nails
Capacity	225~300 nails
Operating Pressure	100~200 psi

### APPLICATION

- Construction work (ex: siding, roofing and sheathing).
- Use for wooden cases, light pallets, wooden furniture, wooden sashes and other wood products

### FEATURES

- Accepts 2.5mm up through 3.3mm shank
- Powerful motor provides penetration through the toughest materials
- Lightweight design prevents arm fatigue for user
- Ergonomic comfort handgrip provides a firm grip for user
- Durable driver and piston o-ring assembly
- Convenient depth of drive dial allows precise nail settings
- Similar to Max CN80, and Hitachi NV83A
- Adjustable exhaust cover and safety



## 16° Wire Collated Coil Nailer

Model No: CN80M

■ All parts compatible with MAX@CN80

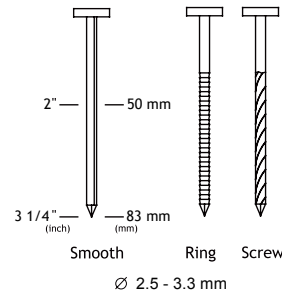

Model No	CN80M
L x W x H	307x132x362 mm
Weight	3.7 kgs
Angle	16°
Fastener Range	50~83 mm
Shank Type	Smooth / Ring / Screw
Capacity	300 pcs
Operating Pressure	85~120 psi

### APPLICATION

- Making and repairing pallets
- Crating
- Fencing
- Siding
- Decking
- Sheathing

### FEATURES

- Extra heavy-duty: Die casting aluminium construction
- Light weight and powerful
- Rugged magazine
- Drives 300 nails continuously by full-loading
- Multi-directional exhaust
- Comfortable rubber grip
- Equipped with dust cover and body protector

## 16° Wire Collated Coil Nailer

Model No: CN70M

■ All parts compatible with MAX CN70

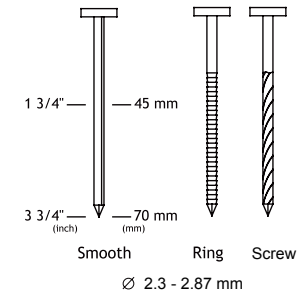

Model No	CN70M
L x W x H	306x128x315 mm
Weight	3.5 kgs
Angle	16°
Fastener Range	45~70 mm
Shank Type	Smooth / Ring / Screw
Capacity	225~300 pcs
Operating Pressure	70~100 psi

### APPLICATION

- Making and repairing pallets
- Crating
- Fencing
- Siding
- Decking
- Sheathing

### FEATURES

- Extra heavy-duty: Die casting aluminium construction
- Light weight and powerful
- Rugged magazine
- Drives 225~300 nails continuously by full-loading
- Multi-directional exhaust
- Comfortable rubber grip
- Equipped with dust cover and body protector



## Heavy Duty Coil Nailer

Model No: CN70AC

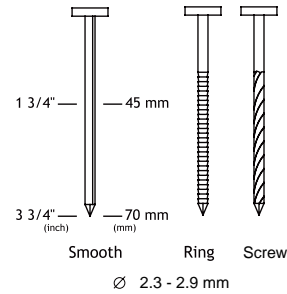

## Heavy Duty Coil Nailer

Model No: CN70H

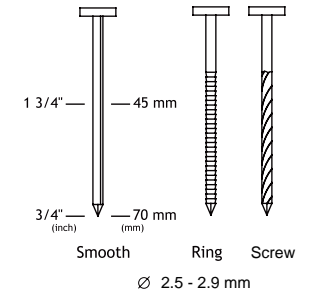

Model No	CN70AC
L x W x H	320x125x318 mm
Weight	3.62 kgs
Angle	15°
Fastener Range	45~70 mm
Shank Type	Smooth / Ring / Screw
Capacity	300 pcs
Working Pressure	70~100 psi

### APPLICATION

- Packaging, crating, pallets
- Siding, sheathing, paneling, fencing
- Industrial, pre-fabricated housing

### FEATURES

- Ergonomic design, well balanced
- Powerful, rapid nailing performance
- Body protectors equipped
- Nail punchers for pallet recycling available
- Top exhaust cap available

Model No	CN70H
L x W x H	300x98x330 mm
Weight	3.12 kgs
Angle	15°
Nail Shank Dia	2.5~2.9 mm
Fastener Range	45~70 mm
Capacity	300 pcs

### APPLICATION

- Decking
- Sheathing
- Subfloors
- Crate and pallet construction
- Exterior trim

### FEATURES

- Ergonomic design, well balanced
- Powerful, rapid nailing performance
- Body protectors equipped
- Nail punchers for pallet recycling available
- Top exhaust cap available





## Wire Coil Nailer

Model No: CN70A1

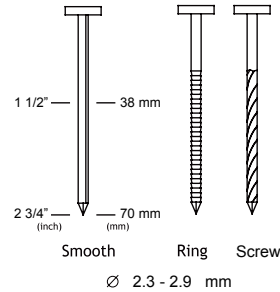

## Construction Coil Nailer

Model No: CN65WPA, CN65WPB

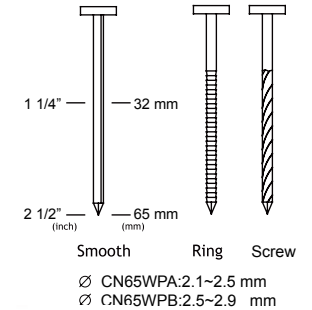

Model No	CN70A1
L x W x H	300x130x360 mm
Weight	3.45 kgs
Nail Shank Dia	2.3~2.9 mm
Length	38~70 mm
Capacity	250~300 pcs
Working Pressure	100~120 psi

### APPLICATION

- Construction work ( ex: siding, roofing and sheathing)
- Use for wooden cases, light pallets, wooden furniture, wooden sashes and other wood products

### FEATURES

- Accepts 2.5mm up through 2.87mm shank
- Powerful motor provides penetration through the toughest materials
- Lightweight design prevents arm fatigue for user
- Ergonomic comfort handgrip provides a firm grip for user
- Durable driver and piston o-ring assembly
- Convenient depth of drive dial allows precise nail settings
- Adjustable exhaust cover and safety
- Similar to Max CN70, and Hitachi NV 65

Model No	CN65WPA	CN65WPB
L x W x H	300x135x320 mm	
Weight	2.74 kgs	
Angle	15°	
Head Dia	5.0~6.0 mm	6.0~7.0 mm
Fastener Range	32~65 mm	
Shank Type	Smooth / Ring / Screw	
Capacity	300 pcs	
Working Pressure	75~100 psi	

### APPLICATION

- Construction work ( ex: siding, roofing and sheathing)
- Use for wooden cases
- Light pallets
- Wooden furniture
- Wooden sashes and other wood products

### FEATURES

- 360 degree exhaust deflector allows exhaust of air in any direction
- Depth of drive adjustment to countersink or flush drive nails
- Lightweight design prevents arm fatigue for user
- Drives wire and plastic sheet collated nails



## Wire Coil Nailer

Model No: CN60A1

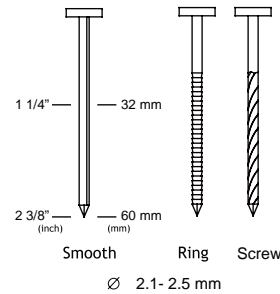

## Heavy Duty Coil Nailer

Model No: CN2557

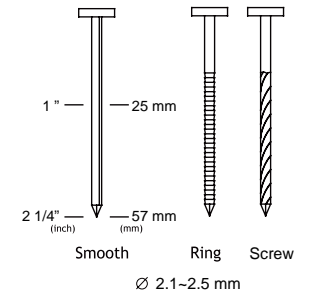

Model No	CN60A1
L x W x H	270x130x270 mm
Weight	2.54 kgs
Nail Shank Dia	2.1~2.5 mm
Length	32~60 mm
Capacity	350 pcs
Working Pressure	100~120 psi

### APPLICATION

- Construction work (ex: siding, roofing and sheathing)
- Use for wooden cases, light pallets, wooden furniture, wooden sashes and other wood products

### FEATURES

- Accepts 2.1mm up through 2.5mm shank
- Powerful motor provides penetration through the toughest materials
- Lightweight design prevents arm fatigue for user
- Adjustable exhaust cover
- Ergonomic comfort handgrip provides a firm grip for user
- Convenient depth of drive dial allows precise staple settings
- Similar to Max CN55

Model No	CN2557
L x W x H	270x90x275 mm
Weight	2.53 kgs
Angle	15°
Fastener Range	25~57 mm
Shank Type	Smooth / Ring / Screw
Capacity	350 pcs
Working Pressure	80~115 psi

### APPLICATION

- Packaging, crating, pallets
- Siding, sheathing, paneling, fencing
- Industrial, Pre-Fabricated housing

### FEATURES

- Ergonomic design
- Well balanced
- Powerful rapid nailing performance
- 360 degree adjustable exhaust port
- Body protectors equipped
- Adjustable safety yoke available



## Heavy Duty Coil Nailer

Model No: CN2357

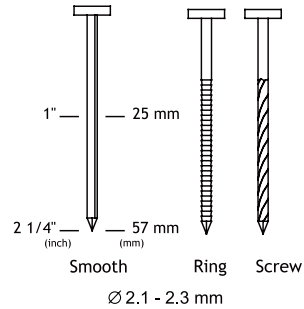

## 16° Wire Collated Coil Nailer

Model No: CN55M

■ All parts compatible with MAX®CN55

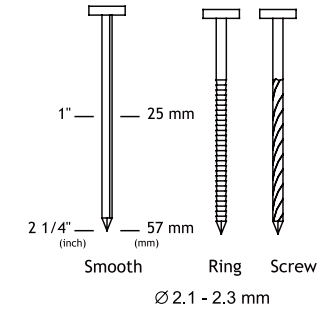

Model No	CN2357
L x W x H	305x130x280 mm
Weight	2.435 kgs
Angle	15°
Fastener Range	25~57 mm
Shank Type	Smooth / Ring / Screw
Capacity	350 pcs
Working Pressure	80~115 psi

### APPLICATION

- Packaging, crating, pallets
- Siding, sheathing, paneling, fencing
- Industrial, Pre-Fabricated housing

### FEATURES

- Ergonomic design, well balanced
- Powerful, rapid nailing performance
- Adjustable safety yoke available
- Body protectors equipped

Model No	CN55M
L x W x H	270x131x283 mm
Weight	2.5 kgs
Angle	16°
Fastener Range	25~57 mm
Shank Type	Smooth / Ring / Screw
Capacity	300~400 pcs
Working Pressure	70~100 psi

### APPLICATION

- Making and repairing pallets
- Crating
- Fencing
- Siding
- Decking
- Sheathing

### FEATURES

- Extra heavy-duty: Die casting aluminium construction
- Light weight and powerful
- Rugged magazine
- Drives 300-400 nails continuously by full-loading
- Multi-directional exhaust
- Comfortable rubber grip
- Equipped with dust cover and body protector



# Duplex Head Coil Nailer

Model No: CN90DH

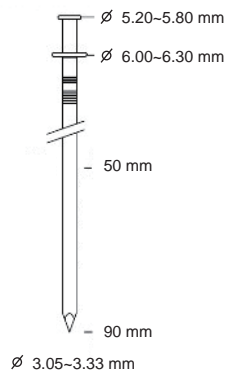

Model No	CN90DH
L x W x H	339x136x344 mm
Weight	3.44 kgs
Fastener Range	50-90 mm
Capacity	200/300 pcs
Operating Pressure	70-120 psi

## APPLICATION

- Crates & containers, load blocking, strapping, prehung door, concrete forming, scaffolding

## FEATURES

- Front exhaust deflector
- Eliminate wasted power design
- Bump fire trigger
- Tool-free depth-adjustment device
- Transparent magazine cover
- Nail tray is sliding out automatically when open magazine cover
- Debris shield keep user from flying debris or serious damage
- Aggressive tip - grab well enough to toenail engineered lumber
- No-mar pad
- Belt hook is accessory for customer option



**VIM INTERNATIONAL ENTERPRISE CO., LTD.**  
 No. 21, Sec. 1, Liouchuan E. Rd., South District,  
 Taichung City 402, Taiwan R.O.C.  
 Tel: 886-4-2373-0103 / Fax: 886-4-2373-0207  
 E-mail: vimcom@ms48.hinet.net / Web: www.evim.com.tw

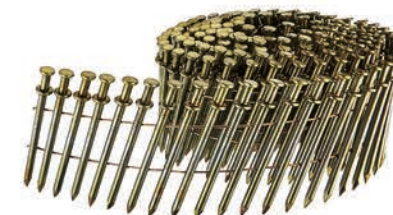

## Cap Coil Nailer

Model No: CN90CP

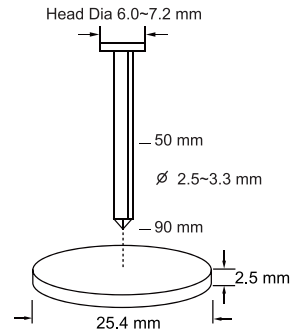

Model No	CN90CP
L x W x H	300x130x330 mm
Weight	3.6 kgs
Head Dia	6.0~7.2 mm
Shank Dia	Wire coil nails dia : 2.5~3.3 mm Plastic coil nails dia : 2.5~2.9 mm
Fastener Range	83~130 mm
Magazine Type	Flat and Convex type
Capacity	Wire coil nails : 400 pcs Plastic coil nails : 200 pcs
Operating Pressure	100~120 psi

### APPLICATION

- Roofing felt
- Foam and fiberboard sheathing
- Insulation house wrap cardboard or carton to pallet

### FEATURES

- 360 degree exhaust deflector allows exhaust of air in any direction
- Depth of adjustment to countersink of flush drive nails
- Lightweight design prevents arm fatigue for user
- Drives wire and plastic sheet collated nails
- Use plastic cap, metal cap, stainless cap, waterproof stainless cap

## Cap Coil Nailer

Model No: CN65CPA, CN65CPB

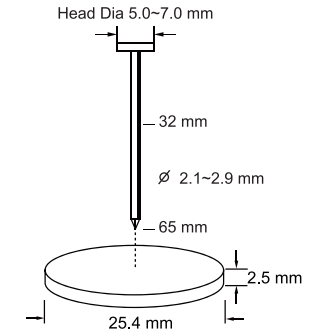

Model No	CN65CPA	CN65CPB
L x W x H	300x130x330 mm	
Weight	3.6 kgs	
Head Dia	6.0~7.2 mm	5.0~6.0 mm
Shank Dia	2.5~2.9 mm	2.1~2.5 mm
Fastener Range	32~65 mm	
Magazine Type	Flat and Convex type	
Capacity	200~300 nails	
Operating Pressure	100~120 psi	

### APPLICATION

- Roofing felt
- Foam and fiberboard sheathing
- Insulation house wrap cardboard or carton to pallet

### FEATURES

- 360 degree exhaust deflector allows exhaust of air in any direction
- Depth of adjustment to countersink of flush drive nails
- Lightweight design prevents arm fatigue for user
- Drives wire and plastic sheet collated nails



# Multi-Construction Nailer

Model No: DN42

Single or bump fire

Tool-free depth control

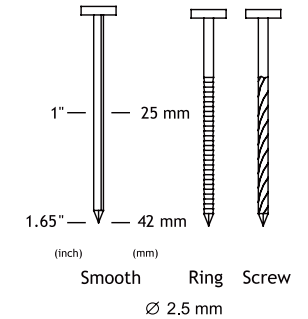

Accurate nailing device for driving nails into material straightly

Model No	DN42
L x W x H	205x103x203 mm
Weight	1.4 kgs
Max Head Dia	6.8 mm
Shank Dia	2.5 mm
Nail Length	25~42 mm
Capacity	200 nails
Operating Pressure	90~110 psi

## APPLICATION

- Drywall installation
- Roof and wall claddings of aluminium, stainless steel or titanium zinc
- Valley boards and metal sheet fixing on wood
- Ideal for slate cladding
- Metal connectors

## FEATURES

- Single or bump fire
- Adjustable exhaust cover
- Straight drive nail holders in nose ensure nails will be driven straight
- Light weight
- Adjustable safety
- Dial adjustable depth control
- Special nose with no-mar tip
- 360 degree adjustable exhaust
- Exhaust silencer
- Ergonomic, rubbered handle grip

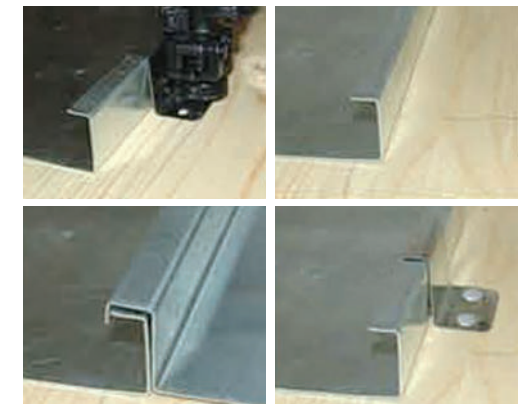

Suitable for all types of metal connectors



## 21 GA. 2 In 1 Pin Nailer With Rear Exhaust

Model No: RPT850R

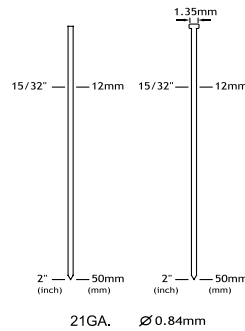

Model No	RPT850R
L x W x H	255x60x225 mm
Weight	1.35 kgs
Gauge	21 GA
Shank Dia	0.84 mm
Fastener Range	12~50 mm
Capacity	150 pcs
Working Pressure	70~100 psi

### APPLICATION

- Light wood assy
- Finish and trim work
- Decorative trim
- Dowel and joint pinning
- Mirror and picture frame assy
- Glazing stips
- Craft work
- Paneling external softwood trim
- Wall framing
- Truss construction
- Rattan furniture
- Window beading
- Display and sign work

### FEATURES

- Drives headless pins and small head brads
- Rear exhaust with Silence
- The patented adjust-free magazine for easy using any fastener length
- Double trigger safety lock helps prevent accidental firing of the tool
- Removable nose cover provides easy access to clear fastener jams
- A narrow nose on the pinners allows the tool to reach into tight areas, and detailed work surfaces
- The storage area provides easy access to your no-mar rubber tip and hex wrench used for removing the nose plate
- Auto Lock-out prevents dry-firing of the tool
- The belt hook provides easy carrying of the tool
- The window on the magazine can show if fasteners are low and when reloading is necessary
- A manual override button allows the last several pins to be driven if necessary
- The rear of the magazine is cut-off at an angle to allow the tool to be placed right up to the coner
- Rubber grip for comfort usage

## 21 GA. 2 In 1 Pin Nailer With Rear Exhaust

Model No: PT840F

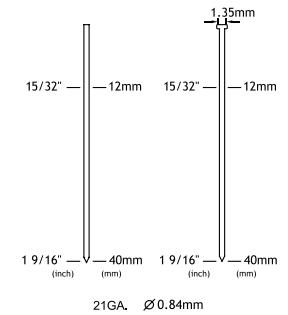

Model No	PT840F
L x W x H	250x43x200 mm
Weight	1.2 kgs
Gauge	21 GA
Shank Dia	0.84 mm
Fastener Range	12~40 mm
Capacity	150 pcs
Working Pressure	70~100 psi

### APPLICATION

- Light wood assy
- Finish and trim work
- Decorative trim
- Dowel and joint pinning
- Mirror and picture frame assy
- Glazing stips
- Craft work
- Paneling external softwood trim
- Wall framing
- Truss construction
- Rattan furniture
- Window beading
- Display and sign work

### FEATURES

- Drives headless pins and micro head brads
- Front exhaust
- The patented adjust-free magazine for easy using any fastener length
- Double trigger safety lock helps prevent accidental firing of the tool
- Removable Nose Cover provides easy access to clear fastener jams
- A narrow nose on the pinners allows the tool to reach into tight areas, and detailed work surfaces
- The window on the magazine can show if fasteners are low and when reloading is necessary
- Rubber grip for comfort usage



## 21 GA. 2 In 1 Pin Nailer With Extended Magazine And Front Exhaust Model No: PT830FL

## 23 GA. 2 In 1 Pin Nailer With Rear Exhaust Model No: RPT650R

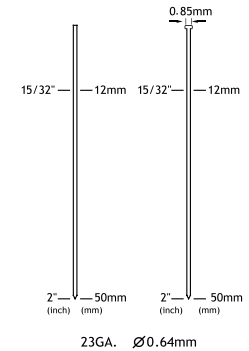
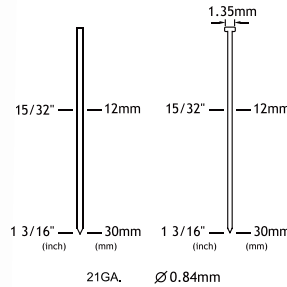

Model No	PT830FL
L x W x H	265x40x175 mm
Weight	1.06 kgs
Gauge	21 GA
Shank Dia	0.84 mm
Fastener Range	12~30 mm
Capacity	150 pcs
Working Pressure	70~100 psi

### APPLICATION

- Light wood assy
- Finish and trim work
- Decorative trim
- Dowel and joint pinning
- Mirror and picture frame assy
- Glazing strips
- Craft work
- Paneling external softwood trim
- Wall framing
- Truss construction
- Rattan furniture
- Window beading
- Display and sign work

Model No	RPT650R
L x W x H	230x65x225 mm
Weight	1.24 kgs
Gauge	23 GA
Shank Dia	0.64 mm
Fastener Range	12~50 mm
Capacity	120 pcs
Working Pressure	70~100 psi

### APPLICATION

- Light wood assy
- Finish and trim work
- Decorative trim
- Dowel and joint pinning
- Mirror and picture frame assy
- Glazing strips
- Craft work
- Paneling external softwood trim
- Wall framing
- Truss construction
- Rattan furniture
- Window beading
- Display and sign work

### FEATURES

- Drives headless pins and small head brads
- Rear exhaust with Silence
- The patented adjust-free magazine for easy using any fastener length
- Double trigger safety lock helps prevent accidental firing of the tool
- Removable nose cover provides easy access to clear fastener jams
- A narrow nose on the pinners allows the tool to reach into tight areas, and detailed work surfaces
- The storage area provides easy access to your no-mar rubber tip and hex wrench used for removing the nose plate
- Auto Lock-out prevents dry-firing of the tool
- The belt hook provides easy carrying of the tool
- The window on the magazine can show if fasteners are low and when reloading is necessary
- A manual override button allows the last several pins to be driven if necessary
- The rear of the magazine is cut-off at an angle to allow the tool to be placed right up to the coner
- Rubber grip for comfort usage
- Extended Magazine for loading more nails
- Removable no-mar rubber tip protect your work surface
- Bigger loading capacity to save your time from reloading pins (200 pcs)
- Plastic end core on magazine for easy and comfort usage

### FEATURES

- Drives headless pins and small head brads
- Rear exhaust with Silence
- The patented adjust-free magazine for easy using any fastener length
- Double trigger safety lock helps prevent accidental firing of the tool
- Removable nose cover provides easy access to clear fastener jams
- A narrow nose on the pinners allows the tool to reach into tight areas, and detailed work surfaces
- The storage area provides easy access to your no-mar rubber tip and hex wrench used for removing the nose plate
- Auto Lock-out prevents dry-firing of the tool
- The belt hook provides easy carrying of the tool
- The window on the magazine can show if fasteners are low and when reloading is necessary
- A manual override button allows the last several pins to be driven if necessary
- The rear of the magazine is cut-off at an angle to allow the tool to be placed right up to the coner
- Rubber grip for comfort usage





## 23 GA. 3 In 1 Built-In Air Blower Pin Nailer

Model No: PT635B

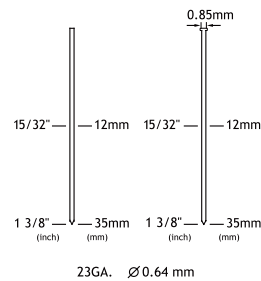

Model No	PT635B
L x W x H	220x52x188 mm
Weight	0.92 kgs
Gauge	23 GA
Shank Dia	0.64 mm
Fastener Range	12~35 mm
Capacity	120 pcs
Working Pressure	70~100 psi

### APPLICATION

- Light wood ass'y
- Finish and trim work
- Decorative trim
- Dowel and joint pinning
- Mirror and picture frame ass'y
- Glazing strips
- Craft work
- Paneling external softwood trim
- Wall framing
- Truss construction
- Rattan furniture
- Window beading
- Display and sign work

### FEATURES

- Light weight & well balanced
- Fine precision nose for easy aiming
- No-mar soft plastic nose tip
- Belt hook
- Magazine sight window
- Trigger safety
- Cushion grip
- Comes with carry case
- Built-in blower gun

## 23 GA. 2 In 1 Pin Nailer

Model No: PT635A1

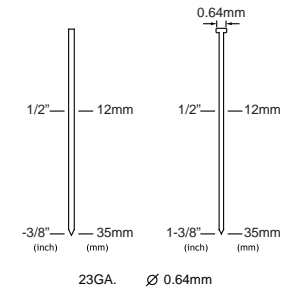

Model No	PT635A1
L x W x H	210x40x200 mm
Weight	1 kgs
Gauge	23 GA
Shank Dia	0.64 mm
Fastener Range	12~35 mm
Capacity	120 pcs
Working Pressure	70~100 psi

### APPLICATION

- Light wood ass'y
- Finish & trim work
- Molding & decorative trim
- Dowel & joint pinning
- Mirror & picture frame ass'y
- Paneling, external softwood trim, wall framing
- Truss construction, roofing

### FEATURES

- Trigger Safety
- Anti-Dry fire Mechanism
- Built in Blow Gun
- Rubber nose tip
- Convenient side loading magazine without any adjustment
- Durable driver unit for long term use
- Long nose for easy aiming



## 23 GA. 2 In 1 Pin Nailer With Rear Exhaust

Model No: RPT635R



Model No	RPT635R
L x W x H	220x58x188 mm
Weight	0.92 kgs
Gauge	23 GA
Shank Dia	0.64 mm
Fastener Range	12~35 mm
Capacity	120 pcs
Working Pressure	70~100 psi

### APPLICATION

- Light wood assy
- Finish and trim work
- Decorative trim
- Dowel and joint pinning
- Mirror and picture frame assy
- Glazing stips
- Craft work
- Paneling external softwood trim
- Wall framing
- Truss construction
- Rattan furniture
- Window beading
- Display and sign work

### FEATURES

- Drives headless pins and micro head brads
- The patented adjust-free magazine for easy using any fastener length
- Double trigger safety lock helps prevent accidental firing of the tool
- Removable nose cover provides easy access to clear fastener jams
- A narrow nose on the pinners allows the tool to reach into tight areas, and detailed work surfaces
- The window on the magazine can show if fasteners are low and when reloading is necessary
- Rubber grip for comfort usage
- Convenient belt hook for easy carrying tool
- Rear Exhaust with Silence
- Plastic end core on magazine for easy and comfort usage
- Quick access magazine storage for wrench and no-mar rubber tip
- Powerful motor penetrates through the hardest materials
- Compact and lightweight design for improved maneuverability
- Side loading with mechanism to prevent fasteners from tumbling
- Removable no-mar tip prevents marring of work surface

## 23 GA. 3 In 1 Built-In Air Blower Pin Nailer

Model No: PT630B

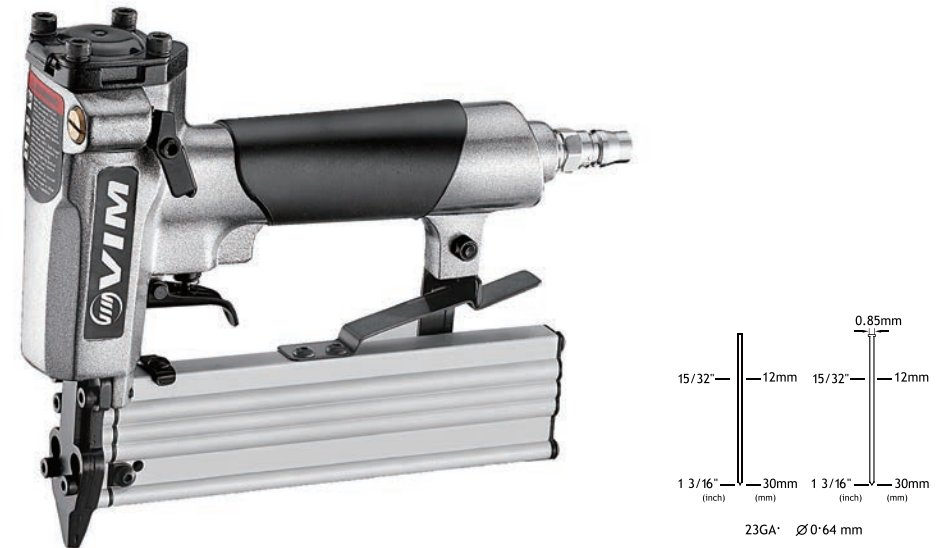

Model No	PT630B
L x W x H	220x52x185 mm
Weight	0.95 kgs
Gauge	23 GA
Shank Dia	0.64 mm
Fastener Range	12~30 mm
Capacity	120 pcs
Working Pressure	70~100 psi

### APPLICATION

- Light wood assy
- Finish and trim work
- Decorative trim
- Dowel and joint pinning
- Mirror and picture frame assy
- Glazing stips
- Craft work
- Paneling external softwood trim
- Wall framing
- Truss construction
- Rattan furniture
- Window beading
- Display and sign work

### FEATURES

- Light weight & well balanced
- Fine precision nose for easy aiming
- No-mar soft plastic nose tip
- Belt hook
- Magazine sight window
- Trigger safety
- Cushion grip
- Comes with carry case
- Built-in blow gun



## 23 GA. 2 In 1 Pin Nailer

Model No: RPT630F

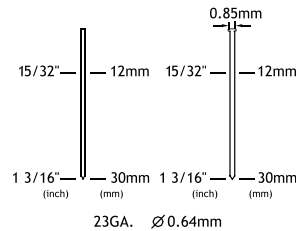

## 23 GA. 2 In 1 Pin Nailer With Rear Exhaust

Model No: RPT630R

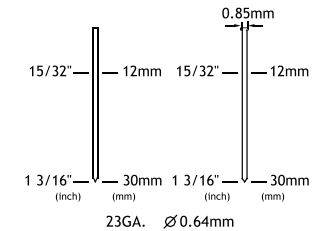

Model No	RPT630F
L x W x H	175x40x220 mm
Weight	1.02 kgs
Gauge	23 GA
Shank Dia	0.64 mm
Fastener Range	12~30 mm
Capacity	120 pcs
Working Pressure	70~100 psi

### APPLICATION

- Light wood assy
- Finish and trim work
- Decorative trim
- Dowel and joint pinning
- Mirror and picture frame assy
- Glazing strips
- Craft work
- Paneling external softwood trim
- Wall framing
- Truss construction
- Rattan furniture
- Window beading
- Display and sign work

Model No	RPT630R
L x W x H	175x40x220 mm
Weight	1.02 kgs
Gauge	23 GA
Shank Dia	0.64 mm
Fastener Range	12~30 mm
Capacity	120 pcs
Working Pressure	70~100 psi

### APPLICATION

- Light wood assy
- Finish and trim work
- Decorative trim
- Dowel and joint pinning
- Mirror and picture frame assy
- Glazing strips
- Craft work
- Paneling external softwood trim
- Wall framing
- Truss construction
- Rattan furniture
- Window beading
- Display and sign work

### FEATURES

- Drives headless pins and micro head brads
- The patented adjust-free magazine for easy using any fastener length
- Double trigger safety lock helps prevent accidental firing of the tool
- Removable nose cover provides easy access to clear fastener jams
- A narrow nose on the pinners allows the tool to reach into tight areas, and detailed work surfaces
- The window on the magazine can show if fasteners are low and when reloading is necessary
- Rubber grip for comfort usage
- Rear exhaust with silence
- Plastic end core on magazine for easy and comfort usage
- Front Exhaust
- The belt hook provides easy carrying of the tool

### FEATURES

- Drives headless pins and micro head brads
- Rear exhaust conveniently directs exhaust away from user and work surface
- The patented adjust-free magazine for easy using any fastener length
- Double trigger safety lock helps prevent accidental firing of the tool
- Removable nose cover provides easy access to clear fastener jams
- A narrow nose on the pinners allows the tool to reach into tight areas, and detailed work surfaces
- The belt hook provides easy carrying of the tool
- The rear of the magazine is cut-off at an angle to allow the tool to be placed right up to the coner
- Rear Exhaust with Silence
- The window on the magazine can show if fasteners are low and when reloading is necessary
- Rubber grip for comfort usage
- Drives headless pins and small head brads



## Finishing Nailer

Model No: DA50

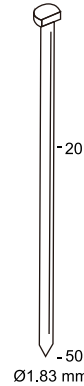

Model No	DA50
L x W x H	320x80x260 mm
Weight	2.04 kgs
Gauge	15 GA
Nail shank dia	1.83 mm
Length	20-50 mm
Capacity	100 pcs

### APPLICATION

- Framing, joiner
- Upholstery, furniture, bedding
- Door, window, trimming, picture frames, building components
- Cabinets, furniture, light wood assembly
- Siding, sheathing, paneling, fencing

### FEATURES

- 360° rotatable air deflector
- Rear load, durable aluminum magazine
- Tool-Free quick release nose cover for easy jam removal
- Tool-Free Depth-of-Drive adjustment
- Removable No-Mar rubber pad
- Swivel belt hook for both left and Right-Handed users

## Finishing Nailer

Model No: DA65

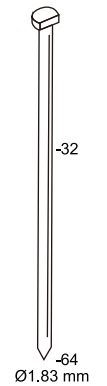

Model No	DA65
L x W x H	330x86x310 mm
Weight	2.36 kgs
Gauge	15 GA
Nail shank dia	1.83 mm
Length	32-64 mm
Capacity	100 pcs

### APPLICATION

- Framing, joiner
- Upholstery, furniture, bedding
- Door, window, trimming, picture frames, building components
- Cabinets, furniture, light wood assembly
- Siding, sheathing, paneling, fencing

### FEATURES

- 360° rotatable air deflector
- Rear load, durable aluminum magazine
- Tool-Free quick release nose cover for easy jam removal
- Tool-Free Depth-of-Drive adjustment
- Removable No-Mar rubber pad
- Swivel belt hook for both left and Right-Handed users



## 15/16 GA. 3 In 1 Finish Nailer

Model No: 1550FN

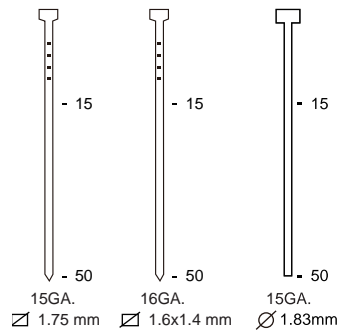

Model No	1550FN		
L x W x H	250x58x250 mm		
Weight	1.4 kgs		
Nail Shank	1.75 mm	1.6x1.4 mm	1.83 mm
Length	15~50 mm		
Gauge	15 GA	16 GA	15 GA
Capacity	80 pcs		
Operating Pressure	70~100 psi		

### APPLICATION

- Upholstery, furniture, bedding
- Door, window, trimming, picture frames, building components
- Cabinets, furniture, light wood assembly
- Packaging, crating, pallets

### FEATURES

- Accept three types of fasteners without any adjustment
- 360° Rotatable air deflector
- Light and compact, ideal for soft wood trimming and fixation of wood to concrete
- Well balanced with comfortable rubber grip
- Removable no-mar rubber pad
- Durable aluminium magazine

## 15 & 16 GA. 2 in 1 Light-Duty Concrete Finishing Nailer

Model No: T50L

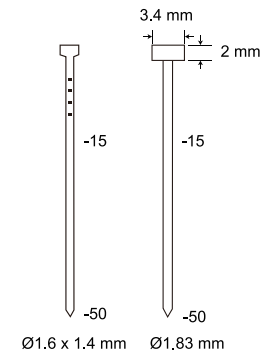

Model No	T50L	
L x W x H	250x58x248 mm	
Weight	1.37 kgs	
Gauge	16 GA	15 GA
Nail shank	1.6x1.4 mm	1.83 mm
Length	15, 20, 25, 30, 32, 35, 38, 40, 45, 50 mm	
Capacity	100 pcs	

### APPLICATION

- Upholstery, Furniture, Bedding
- Door, Window, Trimming, Picture Frames, Building Components
- Cabinets, Furniture, Light wood assembly
- Siding, Sheathing, Paneling, Fencing

### FEATURES

- Accepts both 16 GA finish nails & .072" (1.83 mm) concrete nails
- 360° adjustable air deflector
- Light weight
- Well balanced
- Long magazine
- Holds 2 strips of 16 GA finish nails



## 15 & 16 GA. 2 in 1 Heavy-Duty Concrete Finishing Nailer Model No: T50H



Model No	T50H	
L x W x H	317x72x265 mm	
Weight	1.81 kgs	
Gauge	16 GA	15 GA
Nail shank	1.6x1.4 mm	1.83 mm
Length	18, 20, 25, 30, 32, 38, 40, 45, 50 mm	
Capacity	100 pcs	

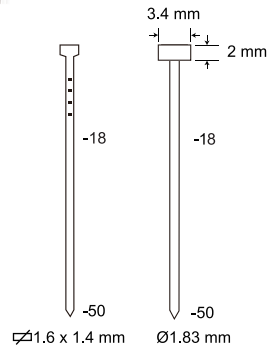

### APPLICATION

- Upholstery, furniture, bedding
- Door, window, trimming, picture frames, building components
- Cabinets, furniture, light wood assembly
- Packaging, crating, pallets
- Siding, sheathing, paneling, fencing
- Industrial, Pre-Fabricated housing

### FEATURES

- Accepts 15/16 GA finish nails
- 360° adjustable air deflector
- Quick release nose cover
- Well balanced

## Finishing Nailer Model No: T1664



Model No	T1664	
L x W x H	317x72x265 mm	
Weight	1.91 kgs	
Gauge	16 GA	
Nail shank	1.6x1.4 mm	
Length	18, 20, 25, 30, 32, 38, 40, 45, 50, 57, 64 mm	
Capacity	100 pcs	



### APPLICATION

- Upholstery, Furniture, Bedding
- Door, Window, Trimming, Picture Frames,
- Building Components
- Cabinets, Furniture, Light wood assembly
- Siding, Sheathing, Paneling, Fencing

### FEATURES

- Accepts 15/16 GA finish nails
- 360° adjustable air deflector
- Quick release nose cover
- Well balanced



## Finishing Nailer

Model No: F1832



Model No	F1832
L x W x H	255x62x205 mm
Weight	0.99 kgs
Gauge	18 GA
Nail shank	1.26x1.05 mm
Length	10, 15, 20, 25, 30, 32 mm
Capacity	100 pcs

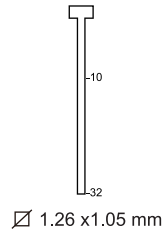

### APPLICATION

- Upholstery, furniture, bedding
- Framing, joiner
- Cabinets, furniture, light wood assembly
- Siding, sheathing, paneling, fencing
- Industrial, Pre-Fabricated housing

### FEATURES

- Light weight
- Easy side loading magazine with visible magazine cover
- Equipped with single / sequential fire switch & driving depth adjustment
- Removable contact tip
- One size hex wrench to assemble / disassemble the tool

## Finishing Nailer

Model No: F1850



Model No	F1850
L x W x H	250x58x248 mm
Weight	1.37 kgs
Gauge	18 GA
Nail shank	1.26x1.05 mm
Length	15, 20, 25, 30, 32, 35, 38, 40, 45, 50 mm
Capacity	100 pcs

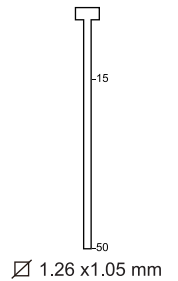

### APPLICATION

- Upholstery, furniture, bedding
- Framing, joiner
- Cabinets, furniture, light wood assembly
- Siding, sheathing, paneling, fencing
- Industrial, Pre-Fabricated housing

### FEATURES

- 360° adjustable air deflector
- Quick release nose cover
- Optional single-bump fire switch available



## 18 GA. 2 in 1 Finishing Nailer

Model No: F1850C

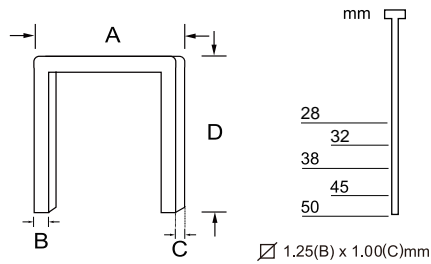

Model No	F1850C
L x W x H	223x58x226 mm
Weight	1.45 kgs
Gauge	18 GA
Crown(A)	6.4 mm
Width(B)xThickness(C)	1.25x1.00 mm
Length(D)	28~40 mm
Capacity	100 pcs
Operating Pressure	70~100 psi

### APPLICATION

- Upholstery, furniture, bedding
- Door, window, trimming, picture frames, building components
- Cabinets, furniture, light wood assembly
- Packaging, crating, pallets

### FEATURES

- Visual reload indicator
- Single-bump fire switch
- Depth adjustment
- No-mar tip
- Bottom load

## Finishing Nailer

Model No: F1857

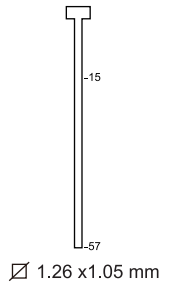

Model No	F1857
L x W x H	255x62x255 mm
Weight	1.21 kgs
Gauge	18 GA
Nail shank	1.26x1.05 mm
Length	15, 20, 25, 30, 32, 35, 38, 40, 45, 50, 55, 57 mm
Capacity	100 pcs

### APPLICATION

- Upholstery, furniture, bedding
- Framing, joiner
- Cabinets, furniture, light wood assembly
- Siding, sheathing, paneling, fencing
- Industrial, Pre-Fabricated housing

### FEATURES

- Light weight
- Easy side loading magazine with visible magazine cover
- Equipped with single / sequential fire switch & driving depth adjustment
- Removable contact tip
- One size hex wrench to assemble / disassemble the tool
- Drive brads from 15~57 mm (19/32"~2 1/4")





## 18 GA. Brad Nailer

Model No: 1850AA



Model No	1850AA
L x W x H	243x58x248 mm
Weight	1.4 kgs
Nail Shank	1.25x1.00 mm
Length	15~50 mm
Gauge	18 GA
Capacity	100 pcs
Operating Pressure	70~100 psi

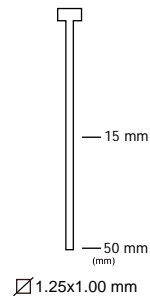

### APPLICATION

- Upholstery, furniture, bedding
- Framing, joiner
- Cabinets, furniture, light wood assembly
- Siding, sheathing, paneling, fencing
- Industrial, pre-fabricated housing

### FEATURES

- 360° Rotatable air deflector
- Quick release nose cover
- Optional single-bump fire switch available
- No-mar rubber pad available

## 18 GA. Brad Nailer

Model No: 1850A1



Model No	1850A1
L x W x H	230x51x235 mm
Weight	1.2 kgs
Gauge	18 GA
Nail shank	1.25x1.00 mm
Length	19~50 mm
Capacity	100 pcs
Working Pressure	70~100 psi

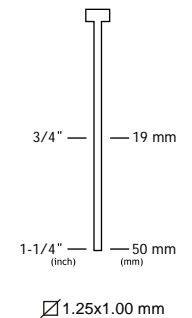

### APPLICATION

- Rattern manufacturers, plastic and wood, overlays, picture frame, sash and door moldings
- Cabinet manufacturers

### FEATURES

- Extended small nose provides access to tight corners and hard to reach areas for accurate brad placement
- Quick release nose cover provides easy access for clearing jams
- Lightweight design prevents arm fatigue for user
- High fastener capacity reduces frequency for reloading
- Convenient side loading provides quick fastener reloading
- Ergonomic comfort handgrip provides a firm grip for user
- 360° adjustable exhaust cover



## T-Nailer

Model No: 2264T

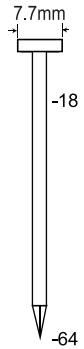

Model No	2264T
L x W x H	310x95x310 mm
Weight	2.8 kgs
Nail shank dia	2.2~2.5 mm
Length	18, 25, 32, 38, 45, 50, 57, 64 mm
Capacity	80 pcs

### APPLICATION

- Roofing, carpentry
- Framing, joiner
- Door, window, trimming, picture frames, building components
- Cabinets, furniture, light wood assembly
- Packaging, crating, pallets
- Industrial, pre-fabricated housing

### FEATURES

- Accept Both .086 & .098" / 2.2 & 2.5 mm
- Concrete nails
- 360° adjustable air deflector
- Powerful
- Well balanced
- Quick release bolted nose
- Sequential trigger mode, can be adjusted to bump fire mode without changing parts



## T-Nailer

Model No: 2264TA

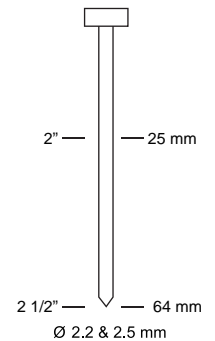

Model No	2264TA
L x W x H	282x94x306 mm
Weight	2.7 kgs
Gauge	14 GA
Shank dia	2.2 & 2.5 mm
Fastener Range	25~64 mm
Capacity	80 pcs
Working Pressure	70~100 psi

### APPLICATION

- Roofing, carpentry
- Framing, joiner
- Door, window, trimming, picture frames, building components
- Cabinets, furniture, light wood assembly
- Packaging, crating, pallets
- Industrial, pre-fabricated housing

### FEATURES

- Accept Both .086 & .098" / 2.2 & 2.5 mm
- Concrete nails
- 360° adjustable air deflector
- Powerful
- Well balanced
- Quick release bolted nose
- Sequential trigger mode, can be adjusted to bump fire mode without changing parts



# Mini Corrugated Nailer

Model No: MCF120, MCF124

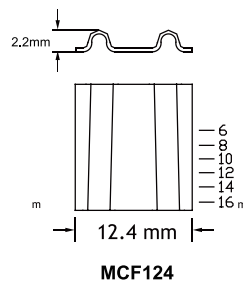
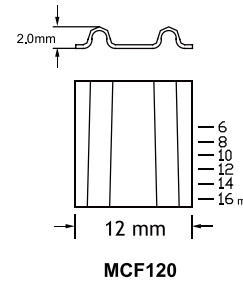

## APPLICATION OF MCF120&MCF124



Butt joints. Inside Mitres. Outside Mitres, Picture Frames and Face Frames

Model No	MCF120	MCF124
L x W x H	355x90x205 mm	
Weight	1.56 kgs	
Crown	12 mm	12.4 mm
Shank Dia	2.0 mm	2.2 mm
Fastener Range	6~16 mm	
Capacity	200 pcs	
Working Pressure	85.2~114 psi	

## APPLICATION

- Trackless carpet strip
- Wood furring
- Floor underlay
- Carpet edge molding
- Installation of metal drywall track
- Door and window
- Furniture and cabinet making
- Face frames
- Picture & mirror frames curios
- All kinds of mitre joint especially where MDF is used
- Compact, lightweight, powerful
- Extra big loading capacity for professional users

## FEATURES

- Plastic end core provide comfort usage
- PATENTED Tool-Free nail length adjustment
- Adjustable deflector conveniently directs exhaust
- Quick bottom loading
- View Window for re-loading nails easily
- Compact, lightweight, powerful
- Big loading capacity for professional users



PATENTED Tool-free nail length adjustment



View Window for re-loading nails easily



# Corrugated Nailers

Model No: CF17, CF25S, CF25P

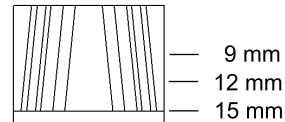
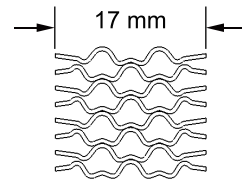

CF17

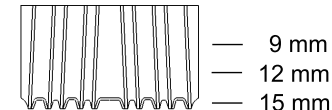
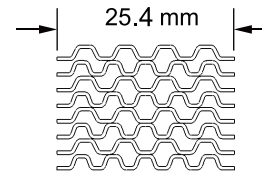

CF25S

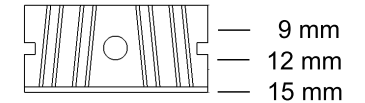
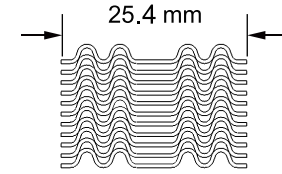

CF25P

Model No	CF17	CF25S	CF25P
L x W x H	280x85x290 mm		
Weight	2.75 kgs		
Crown	17.0 mm	25.4 mm	25.4 mm
Length Of Fastener	9, 12, 15 mm		
Capacity	100 pcs		
Operating Pressure	100-120 psi		

## APPLICATION

- Picture
- Mirror
- Door
- Window frames assembly

## FEATURES

- Perfect balance and light-weight
- High power for hard wood applications
- 360° adjustable exhaust cover.
- Slide-in insert to adjust the different lengths of fasteners
- Fasteners for CF25S equivalent to fasteners for Senco, Ni the operator karma, Atro®, Haubold®, Spotnails®
- Anti-double shot mechanism
- Profiled Nose and extended driver to work on corner joints
- Aluminium alloy housing



With safety device

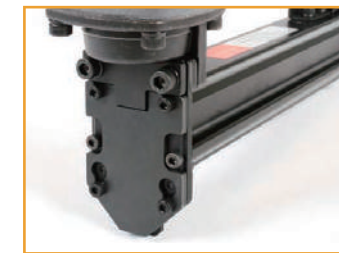

Quick release nose cover provides easy clearing nails jammed



# Corrugated Nailers

Model No: CF175P, CF185S, CF254S, CF264P

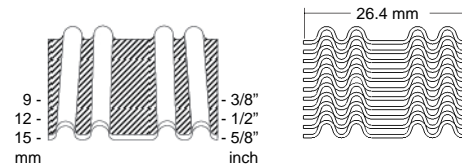

CF264P

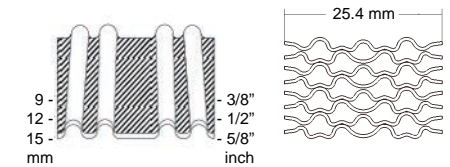

CF254S

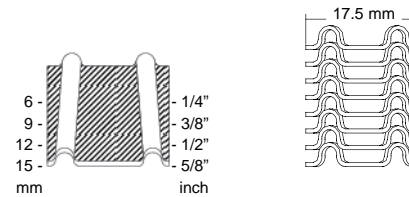

CF175P

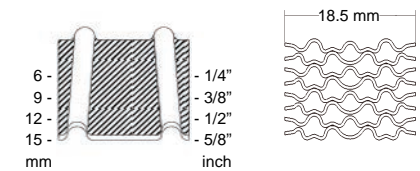

CF185S

Model No	CF175P	CF185S	CF254S	CF264P
L x W x H	300x92x270 mm			
Weight	2.3 kgs		2.4 kgs	
Crown	17.5 mm	18.5 mm	25.4 mm	26.4 mm
Length Of Fastener	6, 9, 12, 15 mm		9, 12, 15 mm	
Capacity	80 pcs	180 pcs	80 pcs	180 pcs
Operating Pressure	100-120 psi			

## APPLICATION

- Furniture, Bedding
- Ticking (Flange) to Innerspring
- Novelty
- Components

## FEATURES

- Adjustable driver length
- Magnesium housing
- Extremely light for using



## Corrugated Nailer

Model No: WN3525



Model No	WN3525
L x W x H	350x110x340 mm
Weight	4 kgs
Crown	35 mm
Fastener Range	12, 15, 18, 25 mm
Loading Capacity	100~120 psi
Working Pressure	100 pcs

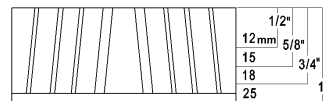
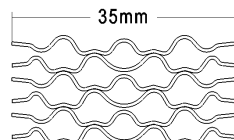

### APPLICATION

- Picture
- Mirror
- Door
- Window frames assembly

### FEATURES

- Perfect balance and light-weight
- High power for hard wood applications
- 360° adjustable exhaust cover
- Slide-in insert to adjust the different lengths of fasteners
- Fasteners for WN3525 equivalent to fasteners for Haubold®, Prebena®, BeA®
- Anti-double shot mechanism
- Profiled Nose and extended driver to work on corner joints
- Aluminium alloy housing

## Roofing Nailer

Model No: RN45 ■ All parts are compatible with Hitachi NV45AB



Model No	RN45
L x W x H	260x110x260 mm
Weight	2.4 kgs
Nail shank dia	3.05 mm
Length	22~45 mm
Capacity	120 pcs

### APPLICATION

- Roofing
- Insulate sheathing and siding

### FEATURES

- Exchangable spare parts with Hitachi roofing coil nailer model No.:NV45AB
- Accepts all 3.05mm diameter 15 degree coil roofing nails
- Adjustable shingle guide for optimal performance
- Durable steel safety foot with carbide inserts
- Lightweight design for improved maneuverability
- Ergonomic comfort handgrip provides a firm grip for user
- Durable driver and o-ring assembly

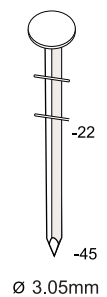

## Air V-Nailer / Picture Framer Nailer

Model No: V15N, V15W

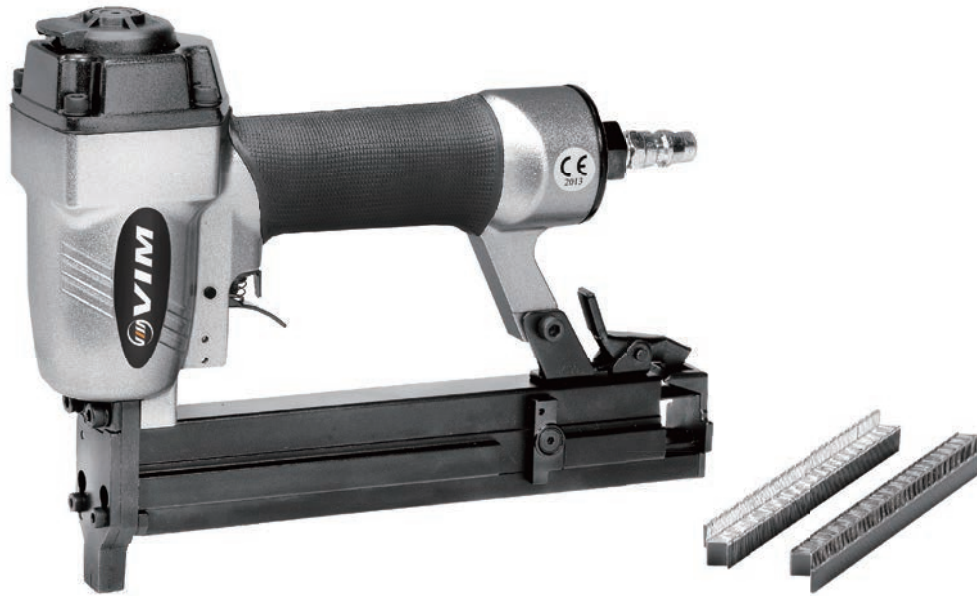

Model No	V15N	V15W
L x W x H	200x70x255 mm	
Weight	1.28 kgs	
Crown (A)	10.3 mm	10.8 mm
Height (B)	4~4.1 mm	4.35~4.45 mm
Thickness (C)	0.3 mm	0.3 mm
Length	7, 10, 12, 15 mm	7, 10, 12, 15 mm
Nail Capacity	300 pcs	300 pcs

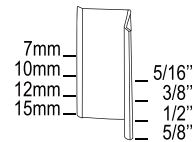
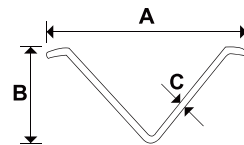

### APPLICATION

- Picture Frame Assembly

### FEATURES

- Lightweight design prevents arm fatigue for user
- Fast easy bottom loading
- Ergonomic comfort handgrip provides a firm grip on tool
- Durable
- Power



# Air Palm Nailer

Model No: AN2



Model No	AN2
L x W x H	100x82x130 mm
Weight	0.95 kgs
Max Nail Head Dia	13 mm

## APPLICATION

- Drives different bulk nails, rivets, leather buttons
- Drives different finish nails and spring pins
- Drives rivets, spring pins and nails into the corner
- Ideal for molding dowels, automotive body works with "No Mar" rubber hammer head
- Ideal for removing plastic floor, carpet, ceramic tile before re-application
- Ideal for digging concrete surface or carving work
- Ideal for digging concrete Chisel

## FEATURES





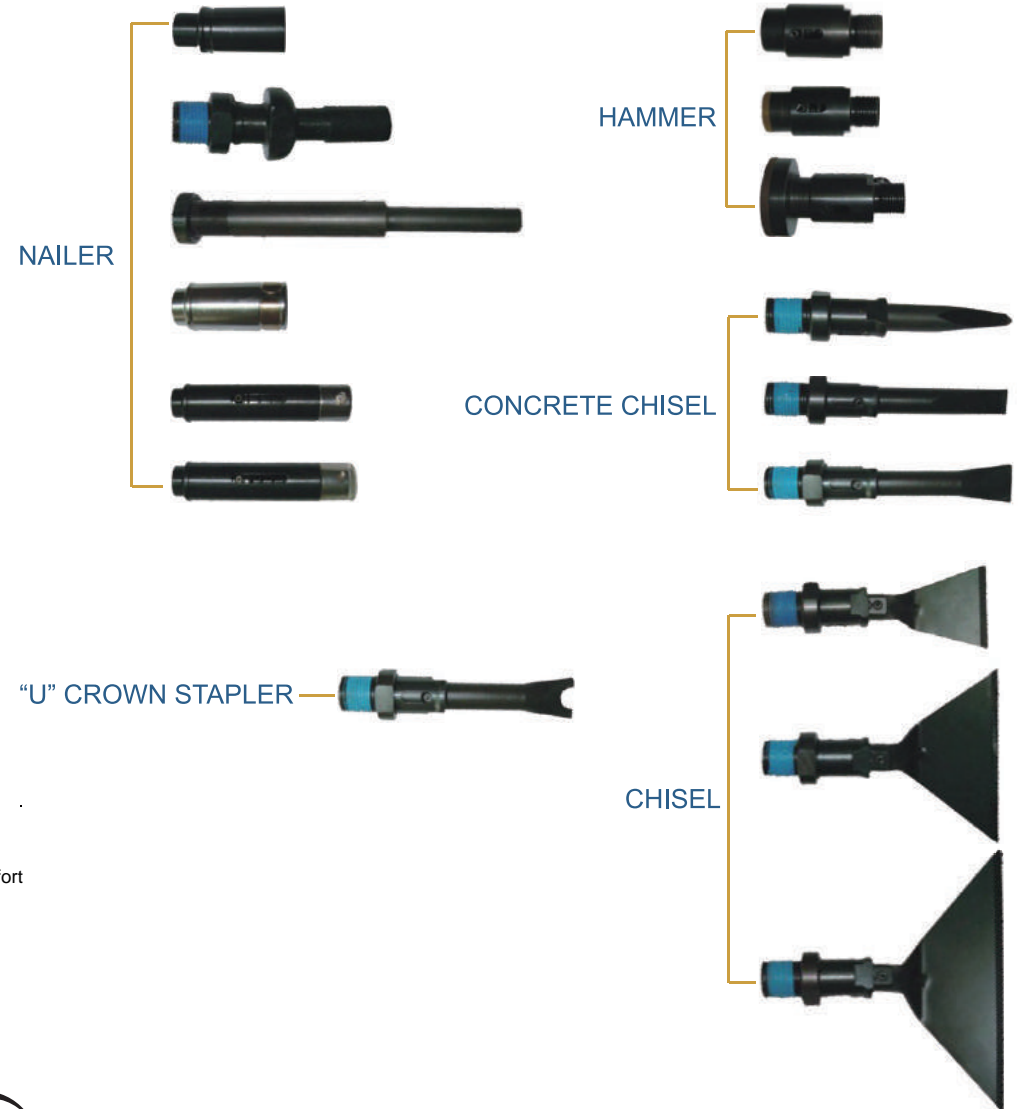

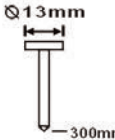

- "No screw cover" with ergonomic design gives comfortable grip
- Patented design effectively reduce the impact for extreme comfort
- All part through hardened treatment for high durability
- Optional adapters
- One-hand operation
- Workable under water

## AN2 ADAPTERS:

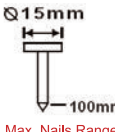



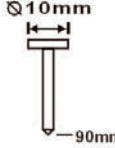
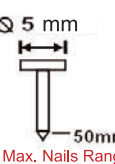

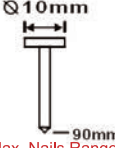
# Adapters for Air Palm Nailer

NAILER	
 	<p><b>Standard Guide Tip</b></p> <ul style="list-style-type: none"> <li>• Drives up to 70d (300mm).</li> <li>• Hardened steel nose for extreme durability.</li> <li>• For nail head 13 mm or under.</li> <li>• Ideal for most type of nails such as notched head nails,clipped head nails,full round-head nails,screw shank nails,ring shank nails...</li> <li>• Ideal for driving most common bulk nails,timber nails and framing nails.</li> </ul>
 	<p><b>15mm Standard Guide Tip</b></p> <ul style="list-style-type: none"> <li>• Extra large nose for longer nails (for nail head 15mm).</li> <li>• Hardened steel nose for extreme durability.</li> <li>• Ideal for most type of nails such as notched head nails,clipped head nails,full round-head nails,screw shank nails,ring shank nails...</li> <li>• Ideal for driving most common bulk nails,timber nails and framing nails.</li> </ul>
 	<p><b>150mm Extra Large Standard Guide Tip</b></p> <ul style="list-style-type: none"> <li>• Hardened steel nose for extreme durability.</li> <li>• Able to drive over 100mm nails.</li> <li>• Long nose stabilizes extra long nails for accurate placement. For nail head 10 mm or under.</li> <li>• Ideal for most common bulk nails,timber nails and framing nails.</li> <li>• Ideal for most type of nails such as notched head nails,clipped head nails,full round-head nails,screw shank nails,ring shank nails...</li> </ul>
 	<p><b>Magnetic Standard Guide Tip</b></p> <ul style="list-style-type: none"> <li>• Magnetic nose stabilizes nails for accurate placement.</li> <li>• Drives up to 16d (90mm)</li> <li>• Hardened steel nose for extreme durability.</li> <li>• For nail head 10mm or under.</li> <li>• Ideal for most type of nails such as notched head nails,clipped head nails,full round-head nails,screw shank nails,ring shank nails...</li> <li>• Ideal for driving most common bulk nails,timber nails and framing nails.</li> </ul>
 	<p><b>Long Magnetic Guide Tip</b></p> <ul style="list-style-type: none"> <li>• Even better in angle and confined areas.</li> <li>• Magnetic nose stabilizes nails for accurate placement.</li> <li>• Drives up to 6d (50mm).</li> <li>• Rubber covered nose makes no scratch.</li> <li>• For nail head 5mm or under.</li> <li>• Ideal for all size of finishing nails.</li> </ul>
 	<p><b>Long Magnetic Guide Tip</b></p> <ul style="list-style-type: none"> <li>• For nail head 10mm or under.</li> <li>• Even better in angle and confined areas.</li> <li>• Magnetic nose stabilizes nails for accurate placement.</li> <li>• Hardened steel nose for extreme durability.</li> <li>• Drives up to 16d (90mm).</li> <li>• Ideal for all size of finishing nails.</li> </ul>

HAMMER	
	<p><b>Steel Hammer</b></p> <ul style="list-style-type: none"> <li>• Can be used as a regular hammer.</li> <li>• Hardened steel hammer for extreme durability.</li> <li>• Ideal for moldings, dowels, automotive body works.</li> </ul>
	<p><b>Rubber Hammer</b></p> <ul style="list-style-type: none"> <li>• "No Mar" rubber hammer head.</li> <li>• Can be used as a regular mallet.</li> <li>• Ideal for moldings, dowels, automotive body works.</li> </ul>
	<p><b>Large Rubber Hammer</b></p> <ul style="list-style-type: none"> <li>• Extra large rubber hammer head.</li> <li>• "No Mar" rubber hammer head.</li> <li>• Can be used as a regular mallet.</li> <li>• Ideal for moldings, dowels, automotive body works.</li> </ul>
CONCRETE CHISEL	
	<p><b>Sharp End Concrete Chisel</b></p> <ul style="list-style-type: none"> <li>• Hardened steel chisel for extreme durability.</li> <li>• Sharp end for exquisite works.</li> <li>• Ideal for digging concrete surfaces or carving work.</li> </ul>
	<p><b>Small Concrete Chisel</b></p> <ul style="list-style-type: none"> <li>• Hardened steel chisel for extreme durability.</li> <li>• 3/4" (20mm) chisel head.</li> <li>• Ideal for digging concrete surfaces or carving work.</li> </ul>
	<p><b>Large Concrete Chisel</b></p> <ul style="list-style-type: none"> <li>• Hardened steel chisel for extreme durability.</li> <li>• 1" (25mm) chisel head.</li> <li>• Extra large head works more efficiently.</li> <li>• Ideal for digging concrete surfaces or carving work.</li> </ul>
"U" CROWN STAPLER	
	<p><b>U type stapler</b></p> <ul style="list-style-type: none"> <li>• Hardened head for extreme durability.</li> <li>• Ideal for fencing, fastening iron wire or wire mesh.</li> </ul>

CHISEL	
	<p><b>Small Chisel</b></p> <ul style="list-style-type: none"> <li>• 2" (50mm) chisel</li> <li>• Hardened steel chisel for extreme durability.</li> <li>• Ideal for removal of plastic floor,carpet, ceramic tile...</li> </ul>
	<p><b>Medium chisel</b></p> <ul style="list-style-type: none"> <li>• 4" (100mm) chisel</li> <li>• Hardened steel chisel for extreme durability.</li> <li>• Ideal for removal of plastic floor,carpet, ceramic tile...</li> </ul>
	<p><b>Large Chisel</b></p> <ul style="list-style-type: none"> <li>• 6" (150mm) chisel</li> <li>• Hardened steel chisel for extreme durability.</li> <li>• Ideal for removal of plastic floor,carpet, ceramic tile...</li> </ul>



## 21° Air Palm Nailer With Swivel Magazine

Model No: AN3



Model No	AN3
L x W x H	336x82x223 mm
Weight	1.84 kgs
Angle	21°
Head Dia	7.5 mm
Shank Dia	3.1~3.8 mm
Nail Length	38 mm
Nail Type	Full round head nails
Magazine Capacity	30 pcs paper strip collation

### APPLICATION

- Metal connector
- Dist hangers
- Decking
- Fastening steel to wood
- Framing
- Trusses

### FEATURES

- U.S and Taiwan patents, effectively reduce the impact from the piston avoiding from uncomfortable and wrist injury. It can still function after a long time of overturn or accidental fall which cause the cylinder sink and airway close.
- Cover arc shaped by ergonomics, with no screws in the cover for a smoother touch. The vent was place in the front and back instead of top to avoid the cause of smudge on hand
- Cylinder surface progress through tust hard coat treatment for high durability and rust less
- Valve surface progress through tust hard coar treatment for high durability
- 7075 piston for high abrasion resistance and stable
- SKD61 driver for superior stable and firm
- The unique design makes the magazine can rotate 360 degree for easier coener working

## 21° Air Palm Nailer With Swivel Magazine

Model No: AN4



Model No	AN4
L x W x H	319x82x295 mm
Weight	1.96 kgs
Angle	21°
Head Dia	7.5 mm
Shank Dia	3.1~3.8 mm
Nail Length	38, 64 mm
Nail Type	Full round head nails
Magazine Capacity	33 pcs plastic or paper strip collation

### APPLICATION

- Metal connector
- Dist hangers
- Decking
- Fastening steel to wood
- Framing
- Trusses

### FEATURES

- U.S and Taiwan patents, effectively reduce the impact from the piston avoiding from uncomfortable and wrist injury. It can still function after a long time of overturn or accidental fall which cause the cylinder sink and airway close.
- Cover arc shaped by ergonomics, with no screws in the cover for a smoother touch. The vent was place in the front and back instead of top to avoid the cause of smudge on hand
- Cylinder surface progress through tust hard coat treatment for high durability and rust less
- Valve surface progress through tust hard coar treatment for high durability
- 7075 piston for high abrasion resistance and stable
- SKD61 driver for superior stable and firm
- The unique design makes the magazine can rotate 360 degree for easier coener working



## 34° Air Palm Nailer With Swivel Magazine

Model No: AN6



Model No	AN6
L x W x H	319x82x295 mm
Weight	1.96 kgs
Angle	34°
Head Dia	7.5 mm
Shank Dia	3.1~3.8 mm
Nail Length	38, 64 mm
Nail Type	Full round head nails
Magazine Capacity	33 pcs paper strip collation

### APPLICATION

- Metal connector
- Dist hangers
- Decking
- Fastening steel to wood
- Framing
- Trusses

### FEATURES

- U.S and Taiwan patents, effectively reduce the impact from the piston avoiding from uncomfortable and wrist injury. It can still function after a long time of overturn or accidental fall which cause the cylinder sink and airway close.
- Cover arc shaped by ergonomics, with no screws in the cover for a smoother touch. The vent was place in the front and back instead of top to avoid the cause of smudge on hand
- Cylinder surface progress through tust hard coat treatment for high durability and rust less
- Valve surface progress through tust hard coar treatment for high durability
- 7075 piston for high abrasion resistance and stable
- SKD61 driver for superior stable and firm
- The unique design makes the magazine can rotate 360 degree for easier coener working

## 34° Air Palm Nailer With Swivel Magazine

Model No: AN7



Model No	AN7
L x W x H	336x82x223 mm
Weight	1.84 kgs
Angle	34°
Head Dia	7.5 mm
Shank Dia	3.1~3.8 mm
Nail Length	38, 40 mm
Nail Type	Full round head nails
Magazine Capacity	30 pcs paper strip collation

### APPLICATION

- Metal connector
- Dist hangers
- Decking
- Fastening steel to wood
- Framing
- Trusses

### FEATURES

- U.S and Taiwan patents, effectively reduce the impact from the piston avoiding from uncomfortable and wrist injury. It can still function after a long time of overturn or accidental fall which cause the cylinder sink and airway close.
- Cover arc shaped by ergonomics, with no screws in the cover for a smoother touch. The vent was place in the front and back instead of top to avoid the cause of smudge on hand
- Cylinder surface progress through tust hard coat treatment for high durability and rust less
- Valve surface progress through tust hard coar treatment for high durability
- 7075 piston for high abrasion resistance and stable
- SKD61 driver for superior stable and firm
- The unique design makes the magazine can rotate 360 degree for easier coener working



## Palm Nailer

Model No: PN90



Model No	AN6
L x W x H	70x56x102 mm
Weight	0.33 kgs



**PN90**  
nail guide  
ø8.7mm

## Palm Nailers

Model No: PN120, PN180



Model No	PN120	PN180
L x W x H	336x82x223 mm	
Weight	1.84 kgs	



**PN120**  
nail guide  
ø11.5mm

**PN180**  
nail guide  
ø13.5mm

## Pneumatic Insulation Nailer

Model No: AI150



Model No	AI150
L x W x H	400x105x360 mm
Weight	2.2 kgs
Nail Shank	2.6~3.1 mm
Concrete Nail Length	45~50 mm
Over All Length	30~150 mm

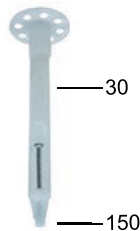

### APPLICATION

- To fix insulation materials onto wall

### FEATURES

- More efficiency and labor-saving
- Great self-powered and easy to maneuver
- Unique design
- Easy maintenance and equipped with maintenance indicator light

## Pneumatic Insulation Nailer

Model No: AI200



Model No	AI200
L x W x H	450x105x360 mm
Weight	2.7 kgs
Nail Shank	3.2~3.6 mm
Concrete Nail Length	42, 52 mm
Over All Length	30~200 mm

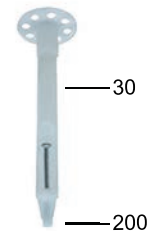

### APPLICATION

- To fix insulation materials onto wall

### FEATURES

- More efficiency and labor-saving
- Great self-powered and easy to maneuver
- Unique design
- Easy maintenance and equipped with maintenance indicator light



## Frame Wedge Nailer

Model No: FW15



Model No	FW15
L x W x H	161x48x225 mm
Weight	0.86 kgs
Crown	5 mm
Thickness	0.35 mm
Length	15 mm
Capacity	300 nails

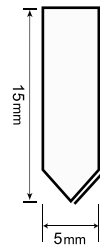
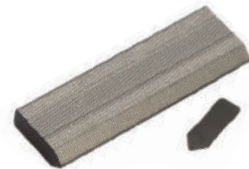

### APPLICATION

- Picture frames
- Mirror frames
- Photo frames
- Window frames assembly

### FEATURES

- Perfect balance and light weight
- High power for hard wood applications
- Slide in insert to adjust the different lengths of fasteners
- Fasteners for CF25S equivalent to fasteners to Senco, Ni the operator karma, Atro, Haubold, Spotnails
- Anti double shot mechanism
- Quick bottom loading
- Plastic end core provide comfort usage

## Manual Point Driver

Model No: MD150



Model No	MD150	
L x W x H	180x63x140 mm	
Weight	0.5 kgs	
Magazine Capacity	150 pcs	

Nail Type	Flexipoints	Arrow head points (Fletcher points)
Crown	12.8 mm	10 mm
Thickness	1x1.15 mm	1.4x1.6 mm
Length	9~16 mm	11~16 mm

Flexipoints

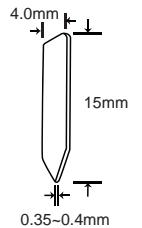

### APPLICATION

- Used in jobs where changeable artwork & photographs are needed
- The best fastener for layered (stacked) and liner mouldings
- Professional quality used to permanently hold glass, art work and backing materials securely in place
- Professional, volume assembly pneumatic drivers
- Making the most trusted points and drivers in the industry

### FEATURES

- Precision firing, no jamming or double feeding
- Spring-adjusted firing power to match wood density
- Used with Fletcher's Framers Points
- Easy-to-load magazine accommodates 150 flexible points
- Lightweight and full-grip trigger provides comfortable firing of points
- Used with Fletcher's flexible points that can be easily bent to change frame contents
- Driver to fire consistently
- Driver won't double-feed

Arrow head points (Fletcher points)

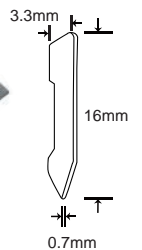
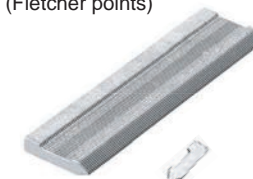

## Gas Fuel Cell Pack



Model No	FC165T
Tool Models Suitable	Paslode IM350, Senco GT90-CH, Max GS683CH-EX, Max GS683RH-EX, Bea Dynamik D90S
Height	165 mm
Capacity	80 mm
Diameter Of Gas Can	32 mm
Fuel Cell Life	1100 pcs



Model No	FC154T
Tool Models Suitable	Powers Trak-It C3, Max GS865E, Hitachi NC40G
Height	154 mm
Capacity	72 mm
Diameter Of Gas Can	32 mm
Fuel Cell Life	1000 pcs



Model No	FC80T
Tool Models Suitable	Paslode IM200F18, Paslode IM250, Paslode IM250A, Paslode IM65F16, Hitachi NT65GB, Hitachi NT65GS
Height	79 mm
Capacity	40 mm
Diameter Of Gas Can	32 mm
Fuel Cell Life	1100 pcs



Model No	FC154M
Tool Models Suitable	Paslode IM350, Paslode CF325, Senco GT90-CH, Max GS683CH-EX, Max GS683RH-EX, Max GS865E, Hitachi NC40G, Powers Trak-It C3, Bea Dynamik D90S
Height	154 mm
Capacity	72 mm
Diameter Of Gas Can	32 mm
Fuel Cell Life	1000 pcs

Leakage Test (After storage over 31 months)						
Expiry Date	EXP 20130701S	Test Date	20140806	Storage over 31 months		Pressure=kg/cm <sup>2</sup>
	Pressure	Test Result	1/2 bottle Test Result	1/6 bottle Test Result	Remark	Weight=(g)
-17°C	6.22	ok	ok	ok	PS : OK means one cycle per 1.5 second	
	6.16	ok	ok	ok		
26°C	Total cycles / Remaining pressure			Total weight before test // Total weight after test		
		1400 // 6.44	86.164 // 51.2			
		1269 // 6.31	86.709 // 52.128			



## Rear Exhaust Upholstery Stapler With Long Nose And Long Magazine

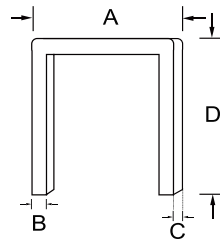

L x W x H	380x197x38 mm
Weight	1.25 kgs
Working Pressure	70~110 psi

Model No	Gauge	Crown(A)	Width(B)xThickness(C)	Length(D)	Capacity
5016LNM	20 GA	12.6 mm	0.5 x 1.25 mm	5~16 mm	220 pcs
7116LNM	22 GA	9.1 mm	0.6 x 0.75 mm	5~16 mm	400 pcs
8016LNM	21 GA	12.9 mm	0.65 x 0.95 mm	5~16 mm	270 pcs
1013L NM	20 GA	11.2 mm	0.6 x 1.2 mm	5~16 mm	220 pcs
1013FLNM	23 GA	11.2 mm	0.5 x 0.7 mm	5~16 mm	400 pcs
A1116LNM	21 GA	9.5 mm	0.5 x 1.3 mm	5~16 mm	220 pcs

### APPLICATION

- Furniture
- Upholstering
- Automotive vinyl
- Interior
- Trim
- House decoration
- Carpet edge

### FEATURES

- Patent one hand manual rear latch(easy loading)
- Compact tool design-less parts
- Powerful(Rapid shooting up to 16mm)
- The shortest fastener 3mm can be shot without tumbling
- Rear air exhaust ,anti dirt on workpiece
- Low air consumption(Save 30 to 40% compare with competitor)
- Durable drive Unit and bumper

## Rear Exhaust Upholstery Stapler With Long Nose And Long Magazine, Auto Firing

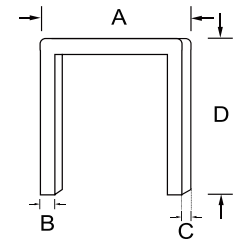

L x W x H	380x197x38 mm
Weight	1.25 kgs
Working Pressure	70~110 psi

Model No	Gauge	Crown(A)	Width(B)xThickness(C)	Length(D)	Capacity
5016ALNM	20 GA	12.6 mm	0.5 x 1.25 mm	5~16 mm	220 pcs
7116ALNM	22 GA	9.1 mm	0.6 x 0.75 mm	5~16 mm	400 pcs
8016ALNM	21 GA	12.9 mm	0.65 x 0.95 mm	5~16 mm	270 pcs
1013A LNM	20 GA	11.2 mm	0.6 x 1.2 mm	5~16 mm	220 pcs
1013FALNM	23 GA	11.2 mm	0.5 x 0.7 mm	5~16 mm	400 pcs
A1116ALNM	21 GA	9.5 mm	0.5 x 1.3 mm	5~16 mm	220 pcs

### APPLICATION

- Furniture
- Upholstering
- Automotive vinyl
- Interior
- Trim
- House decoration
- Carpet edge

### FEATURES

- Patent one hand manual rear latch(easy loading)
- Compact tool design-less parts
- Powerful(Rapid shooting up to 16mm)
- The shortest fastener 3mm can be shot without tumbling
- Rear air exhaust ,anti dirt on workpiece
- Low air consumption(Save 30 to 40% compare with competitor)
- Durable drive Unit and bumper





## Rear Exhaust Upholstery Stapler With Long Nose, Single Firing

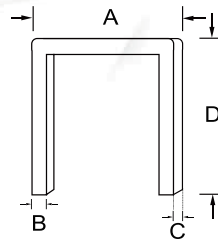

L x W x H	216x197x38 mm
Weight	0.9 kgs
Working Pressure	70~110 psi

Model No	Gauge	Crown(A)	Width(B)xThickness(C)	Length(D)	Capacity
5016SLN	20 GA	12.6 mm	0.5 x 1.25 mm	5~16 mm	100 pcs
7116SLN	22 GA	9.1 mm	0.6 x 0.75 mm	5~16 mm	150 pcs
8016SLN	21 GA	12.9 mm	0.65 x 0.95 mm	5~16 mm	100 pcs
1013\$ LN	20 GA	11.2 mm	0.6 x 1.2 mm	5~16 mm	100 pcs
1013FSLN	23 GA	11.2 mm	0.5 x 0.7 mm	5~16 mm	150 pcs
A1116SLN	21 GA	9.5 mm	0.5 x 1.3 mm	5~16 mm	100 pcs
6416SLN	22 GA	12.5 mm	0.55 x 0.75 mm	6~16 mm	100 pcs

### APPLICATION

- Furniture
- Upholstering
- Automotive vinyl
- Interior
- Trim
- House decoration
- Carpet edge

### FEATURES

- Patent one hand manual rear latch(easy loading)
- Compact tool design-less parts
- Powerful(Rapid shooting up to 16mm)
- The shortest fastener 3mm can be shot without tumbling
- Rear air exhaust ,anti dirt on workpiece
- Low air consumption(Save 30 to 40% compare with competitor)
- Durable drive Unit and bumper

## Rear Exhaust Upholstery Stapler With Long Nose, Auto Firing

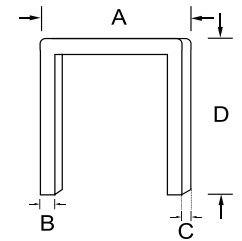

L x W x H	216x197x38 mm
Weight	0.9 kgs
Working Pressure	70~110 psi

Model No	Gauge	Crown(A)	Width(B)xThickness(C)	Length(D)	Capacity
5016ALN	20 GA	12.6 mm	0.5 x 1.25 mm	5~16 mm	100 pcs
7116ALN	22 GA	9.1 mm	0.6 x 0.75 mm	5~16 mm	150 pcs
8016ALN	21 GA	12.9 mm	0.65 x 0.95 mm	5~16 mm	100 pcs
1013A LN	20 GA	11.2 mm	0.6 x 1.2 mm	5~16 mm	100 pcs
1013FALN	23 GA	11.2 mm	0.5 x 0.7 mm	5~16 mm	150 pcs
6416ALN	22 GA	12.5 mm	0.55 x 0.75 mm	6~16 mm	100 pcs

### APPLICATION

- Furniture
- Upholstering
- Automotive vinyl
- Interior
- Trim
- House decoration
- Carpet edge

### FEATURES

- Patent one hand manual rear latch(easy loading)
- Compact tool design-less parts
- Powerful(Rapid shooting up to 16mm)
- The shortest fastener 3mm can be shot without tumbling
- Rear air exhaust ,anti dirt on workpiece
- Rapid trigger valve - 20 shots/ @second
- Low air consumption(Save 30 to 40% compare with competitor)
- Durable drive Unit and bumper



## 21 GA. Rear Exhaust Stapler, Single Firing Model No: 8025



Model No	8025
L x W x H	215x55x180 mm
Weight	1.2 kgs
Gauge	21 GA
Crown	12.9 mm
Staple Size	0.64x0.95 mm
Fastener Range	12~25 mm
Working Pressure	70~110 psi
Capacity	100 pcs

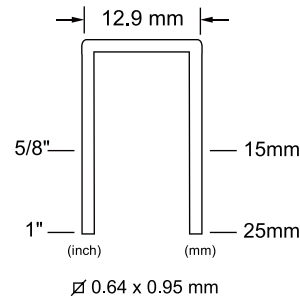

### APPLICATION

- Furniture
- Upholstering
- Automotive vinyl
- Interior trim
- House decoration

### FEATURES

- Compact tool design-less parts
- Compact size
- Lightest in the world, 1.2 kgs only
- One hand manual rear latch for easy loading
- Rear air exhaust / anti dirt on workpiece
- Rapid trigger valve 20 shoots, second
- Single, auto shoot adjustable (From 1 to 20)
- Low air consumption (Save 30 to 40% compare with competitor)
- Durable drive unit and Bumper

## 21 GA. Rear Exhaust Stapler, Single Firing Model No: 8025A



Model No	8025
L x W x H	215x55x180 mm
Weight	1.2 kgs
Gauge	21 GA
Crown	12.9 mm
Staple Size	0.64x0.95 mm
Fastener Range	12~25 mm
Working Pressure	70~110 psi
Capacity	100 pcs

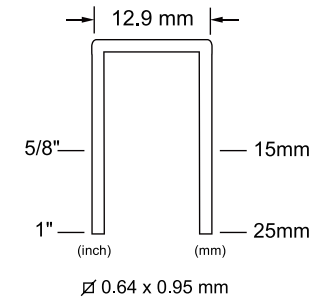

### APPLICATION

- Furniture
- Upholstering
- Automotive vinyl
- Interior trim
- House decoration

### FEATURES

- Compact tool design-less parts
- Compact size
- Lightest in the world, 1.2 kgs only
- One hand manual rear latch for easy loading
- Rear air exhaust / anti dirt on workpiece
- Rapid trigger valve 20 shoots, second
- Single, auto shoot adjustable (From 1 to 20)
- Low air consumption (Save 30 to 40% compare with competitor)
- Durable drive unit and Bumper



## 20 GA. Auto Firing Stapler

Model No: 1016JA



Model No	1016A
L x W x H	220x43x163 mm
Weight	1 kgs
Gauge	20 GA
Crown (A)	11.2 mm
Width(B)xThickness(C)	1.2x0.6 mm
Length(D)	6~16 mm
Operating Pressure	5~7 kg/cm <sup>2</sup>
Capacity	100 staples

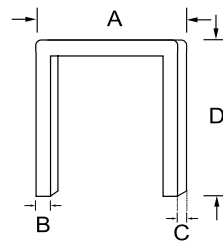

### APPLICATION

- Upholstery, furniture, bedding
- Door, window, trimming, picture frames, building components
- Cabinets, light wood assembly
- Siding, sheathing, paneling, fencing

### FEATURES

- Hammer cap
- Bottom load, jam free magazine
- Rear exhaust to avoid oil stains on work piece
- Slim long nose for easy, precise staple placement
- Comfortable rubber grip

## 21 GA. Auto Firing Stapler With Long Magazine

Model No: 1116AALM



Model No	1116AALM
L x W x H	352x45x148 mm
Weight	1.1 kgs
Gauge	21 GA
Crown (A)	10.8 mm
Width(B)xThickness(C)	0.53x1.25 mm
Length(D)	6~16 mm
Operating Pressure	6~7.7 kg/cm <sup>2</sup>
Capacity	216 staples

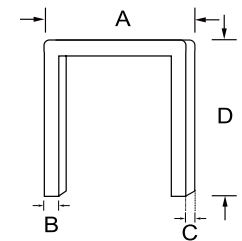

### APPLICATION

- Upholstery, furniture, bedding
- Cabinets, light wood assembly
- Packaging, crating, pallets
- Industrial, pre-fabricated housing

### FEATURES

- Speed adjustable
- Minimum 27 staplers/sec when adjusted to highest speed
- Light squeeze trigger to single fire
- Full squeeze to Auto-Fire no adjustment needed
- Hammer cap
- Rear exhaust cover
- Bottom load magazine - Quick load and easy jam clearance
- Low fastener re-load indicator window



## 21 GA. Auto Firing Stapler

Model No: 8016AA



## 21 GA. Auto Firing Stapler With Long Magazine

Model No: 8016AALM



Model No	8016AA
L x W x H	220x45x148 mm
Weight	1 kgs
Gauge	21 GA
Crown (A)	12.8 mm
Width(B)xThickness(C)	0.91x0.71 mm
Length(D)	6~16 mm
Operating Pressure	6~7.7 kg/cm <sup>2</sup>
Capacity	100 staples

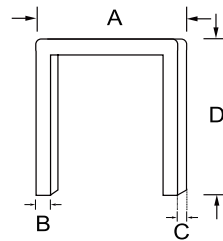

Model No	8016AALM
L x W x H	352x45x148 mm
Weight	1.1 kgs
Gauge	21 GA
Crown (A)	12.8 mm
Width(B)xThickness(C)	0.91x0.71 mm
Length(D)	6~16 mm
Operating Pressure	6~7.7 kg/cm <sup>2</sup>
Capacity	290 staples

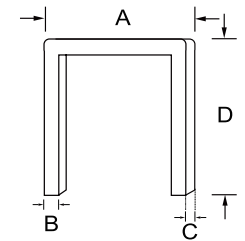

### APPLICATION

- Upholstery, furniture, bedding
- Cabinets, light wood assembly
- Packaging, crating, pallets
- Industrial, pre-fabricated housing

### FEATURES

- Speed adjustable
- Minimum 27 staplers/sec when adjusted to highest speed
- Light squeeze trigger to single fire, full squeeze to Auto-Fire no adjustment needed
- Hammer cap
- Rear exhaust
- Bottom load long magazine - quick load and easy jam clearance

### APPLICATION

- Upholstery, furniture, bedding
- Cabinets, light wood assembly
- Packaging, crating, pallets
- Industrial, pre-fabricated housing

### FEATURES

- Speed adjustable
- Minimum 27 staplers/sec when adjusted to highest speed
- Light squeeze trigger to single fire
- Full squeeze to Auto-Fire no adjustment needed
- Hammer cap
- Rear exhaust
- Bottom load long magazine - quick load and easy jam clearance
- Low fastener Re-Load indicator window



## 22 GA. Auto Firing Stapler

Model No: 7116AA



## 22 GA. Auto Firing Stapler With Long Magazine

Model No: 7116AALM



Model No	7116AA
L x W x H	220x45x148 mm
Weight	1 kgs
Gauge	22 GA
Crown (A)	9.1 mm
Width(B)xThickness(C)	0.75x0.61 mm
Length(D)	6~16 mm
Operating Pressure	6~7.7 kg/cm <sup>2</sup>
Capacity	100 staples

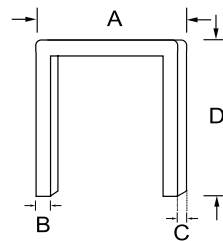

Model No	8016AALM
L x W x H	352x45x148 mm
Weight	1.1 kgs
Gauge	22 GA
Crown (A)	9.1 mm
Width(B)xThickness(C)	0.75x0.61 mm
Length(D)	6~16 mm
Operating Pressure	6~7.7 kg/cm <sup>2</sup>
Capacity	358 staples

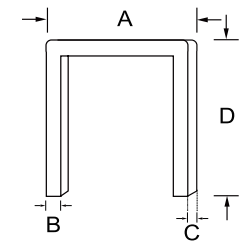

### APPLICATION

- Upholstery, furniture, bedding
- Cabinets, light wood assembly
- Packaging, crating, pallets
- Industrial, pre-fabricated housing

### FEATURES

- Speed adjustable
- Minimum 27 staplers/sec when adjusted to highest speed
- Light squeeze trigger to single fire, full squeeze to Auto-Fire no adjustment needed
- Hammer cap
- Rear exhaust
- Bottom load long magazine - quick load and easy jam clearance

### APPLICATION

- Upholstery, furniture, bedding
- Cabinets, light wood assembly
- Packaging, crating, pallets
- Industrial, pre-fabricated housing

### FEATURES

- Speed adjustable
- Minimum 27 staplers/sec when adjusted to highest speed
- Light squeeze trigger to single fire
- Full squeeze to auto-fire no adjustment needed
- Hammer cap
- Rear exhaust
- Bottom load long magazine - quick load and easy jam clearance
- Low fastener re-load indicator window



## Rear Exhaust Upholstery Stapler With Single Firing

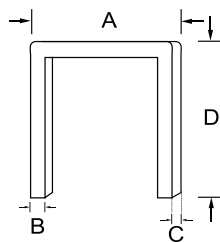

L x W x H	216x140x38 mm
Weight	0.9 kgs

Model No	Gauge	Crown(A)	Width(B)x Thickness(C)	Length(D)	Capacity	Working Pressure
5016S	20 GA	12.6 mm	0.5 x 1.25 mm	5~16 mm	100 pcs	70~110 psi
7116S	22 GA	9.1 mm	0.6 x 0.75 mm	5~16 mm	150 pcs	70~110 psi
8016S	21 GA	12.9 mm	0.65 x 0.95 mm	5~16 mm	100 pcs	70~110 psi
1013S	20 GA	11.2 mm	0.6 x 1.2 mm	5~16 mm	100 pcs	70~110 psi
1013FS	23 GA	11.2 mm	0.5 x 0.7 mm	5~16 mm	150 pcs	70~110 psi
A1116S	21 GA	9.5 mm	0.5 x 1.3 mm	5~16 mm	100 pcs	70~110 psi
6416S	22 GA	12.5 mm	0.55 x 0.75 mm	5~16 mm	150 pcs	70~110 psi
416JS	20 GA	5.2 mm	0.6 x 1.2 mm	5~16 mm	100 pcs	70~110 psi
SNCA16S	22 GA	4.7 mm	0.6 x 0.75 mm	5~16 mm	150 pcs	70~110 psi
SK 16S	22 GA	4.1 mm	0.6 x 0.75 mm	5~16 mm	150 pcs	70~110 psi
9716S	21 GA	4.5 mm	0.65 x 0.95 mm	5~16 mm	100 pcs	70~110 psi
4016S	21 GA	4.7 mm	0.65 x 0.95 mm	5~16 mm	100 pcs	70~110 psi
9916S	21 GA	5.5 mm	0.65 x 0.95 mm	5~16 mm	100 pcs	70~110 psi

### APPLICATION

- Furniture
- Upholstering
- Automotive vinyl
- Interior
- Trim
- House decoration
- Carpet edge

### FEATURES

- Compact tool design-less parts
- Powerful(Rapid shooting up to 16mm)
- The shortest fastener 3mm can be shot without tumbling
- Compact size
- Light weight
- One hand manual rear latch(easy loading)
- Rear air exhaust, anti dirt on workpiece
- Low air consumption(Save 30 to 40% compare with competitor)
- Durable drive Unit and bumper

## Rear Exhaust Upholstery Stapler With Auto Firing

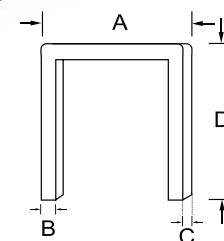

L x W x H	216x140x38 mm
Weight	0.9 kgs

Model No	Gauge	Crown(A)	Width(B)x Thickness(C)	Length(D)	Capacity	Working Pressure
5016A	20 GA	12.6 mm	0.5 x 1.25 mm	5~16 mm	100 pcs	70~110 psi
7116A	22 GA	9.1 mm	0.6 x 0.75 mm	5~16 mm	150 pcs	70~110 psi
8016A	21 GA	12.9 mm	0.65 x 0.95 mm	5~16 mm	100 pcs	70~110 psi
1013A	20 GA	11.2 mm	0.6 x 1.2 mm	5~16 mm	100 pcs	70~110 psi
1013FA	23 GA	11.2 mm	0.5 x 0.7 mm	5~16 mm	150 pcs	70~110 psi
A1116A	21 GA	9.5 mm	0.5 x 1.3 mm	5~16 mm	100 pcs	70~110 psi
6416A	22 GA	12.5 mm	0.55 x 0.75 mm	5~16 mm	150 pcs	70~110 psi
416A	20 GA	5.2 mm	0.6 x 1.2 mm	5~16 mm	100 pcs	70~110 psi
SNCA16A	22 GA	4.7 mm	0.6 x 0.75 mm	5~16 mm	150 pcs	70~110 psi
SK 16A	22 GA	4.1 mm	0.6 x 0.75 mm	5~16 mm	150 pcs	70~110 psi
9716A	21 GA	4.5 mm	0.65 x 0.95 mm	5~16 mm	100 pcs	70~110 psi
4016A	21 GA	4.7 mm	0.65 x 0.95 mm	5~16 mm	100 pcs	70~110 psi
9916A	21 GA	5.5 mm	0.65 x 0.95 mm	5~16 mm	100 pcs	70~110 psi

### APPLICATION

- Furniture
- Upholstering
- Automotive vinyl
- Interior
- Trim
- House decoration
- Carpet edge

### FEATURES

- Patent one hand manual rear latch(easy loading)
- Compact tool design-less parts
- Powerful(Rapid shooting up to 16mm)
- The shortest fastener 3mm can be shot without tumbling
- Rear air exhaust, anti dirt on workpiece
- Low air consumption(Save 30 to 40% compare with competitor)
- Durable drive Unit and bumper



## Rear Exhaust Upholstery Stapler With Auto Firing And Long Magazine



L x W x H	380x140x38 mm
Weight	1.2 kgs
Working Pressure	70~100 psi

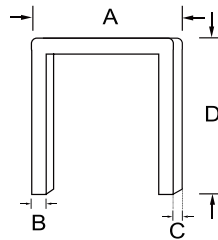

Model No	Gauge	Crown(A)	Width(B)xThickness(C)	Length(D)	Capacity
5016ALM	20 GA	12.6 mm	0.5 x 1.25 mm	5~16 mm	220 pcs
7116ALM	22 GA	9.1 mm	0.6 x 0.75 mm	5~16 mm	400 pcs
8016ALM	21 GA	12.9 mm	0.65 x 0.95 mm	5~16 mm	270 pcs
1013JALM	20 GA	11.2 mm	0.6 x 1.2 mm	5~16 mm	220 pcs
1013FALM	23 GA	11.2 mm	0.5 x 0.7 mm	5~16 mm	400 pcs
A1116ALM	20 GA	10.8 mm	0.5 x 1.22 mm	5~16 mm	220 pcs
6416ALM	22 GA	12.5 mm	0.55 x 0.75 mm	5~16 mm	400 pcs
416JALM	20 GA	5.2 mm	0.6 x 1.2 mm	5~16 mm	220 pcs
SNCA16ALM	22 GA	4.7 mm	0.6 x 0.75 mm	5~16 mm	400 pcs
SJK16ALM	22 GA	4.1 mm	0.6 x 0.75 mm	5~16 mm	400 pcs

### APPLICATION

- Furniture
- Upholstering
- Automotive vinyl
- House decoration

### FEATURES

- Patent rapid trigger valve
- Patent one hand manual rear latch (easy loading)
- Compact tool design-less parts
- Rear air exhaust, anti dirt on workpiece
- Single, auto shoot adjustable (From 1 to 20 shots Per Second)
- Low air consumption (Save 30 to 40% compare with competitor)
- Durable drive unit and bumper

## 2 in 1 Polymer Stapler

Model No: 8016FP



Model No	8016FP	
L x W x H	216x43x148 mm	
Weight	0.9 kgs	
Crown (A)	12.8 mm	10 mm
Width(B)xThickness(C)	1x1.15 mm	1.4x1.6 mm
Length(D)	9~16 mm	11~16 mm
Operating Pressure	60~100 psi	60~100 psi
Capacity	75~80 pcs	75~80 pcs

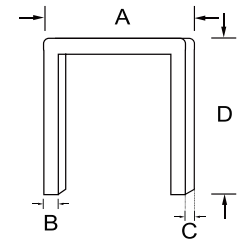

### APPLICATION

- Upholstery, furniture, bedding
- Cabinets, light wood assembly
- Packaging, crating, pallets
- Industrial, pre-fabricated housing

### FEATURES

- Hammer cap
- Bottom load, jam free magazine
- Rear exhaust cover
- Slim long nose for easy aiming
- Accepts both narrow & medium polymer staples



## Polymer Stapler

Model No: 81P, 82P



Model No	81P	82P
L x W x H	216x43x148 mm	
Weight	0.9 kgs	
Gauge	19 GA	16 GA
Crown (A)	12.7 mm	12.7 mm
Width(B)xThickness(C)	1.1x1.25 mm	1.4x1.85 mm
Length(D)	6~16 mm	6~16 mm
Working Pressure	70~110 psi	70~110 psi
Capacity	90 staples	60 staples

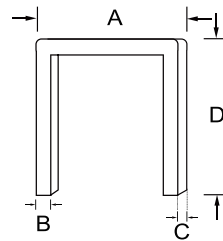

### APPLICATION

- Lumber wrap
- Lumber tagging
- Boatbuilding
- Casket lining
- Doors metal detectors
- Furnitures
- Fiberglass layup
- Upholstery
- Insulating sheathing
- All applications where metal fasteners can damage tools and to avoid fasteners removal

### FEATURES

- Comfortable handle with rubber
- Strong and light weight die cast housing
- Fast and easy down loading

## Fine Wire Staplers

Model No: 8016, 7116, 8416, 1416, 6416, 9516, SF16, 1016J, 1016F

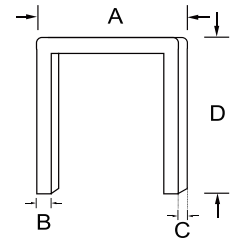

L x W x H	250x58x185 mm
Weight	1.23 kgs

Model No	Gauge	Crown(A)	Width(B)xThickness(C)	Length(D)	Capacity
8016	21 GA	12.90 mm	0.95 x 0.65 mm	4~16 mm	160 pcs
7116	22 GA	9.10 mm	0.75 x 0.60 mm	4~16 mm	200 pcs
8416	21 GA	12.20 mm	1.00 x 0.55 mm	4~16 mm	160 pcs
1416	22 GA	10.08 mm	0.70 x 0.60 mm	4~16 mm	200 pcs
6416	22 GA	12.50 mm	0.75 x 0.55 mm	4~16 mm	100 pcs
9516	21 GA	12.50 mm	1.25 x 0.50 mm	4~16 mm	100 pcs
SF16	21 GA	12.80 mm	1.25 x 0.50 mm	4~16 mm	100 pcs
1016J	20 GA	10.00 mm	1.20 x 0.60 mm	4~16 mm	200 pcs
1016F	22 GA	10.00 mm	0.70 x 0.50 mm	4~16 mm	200 pcs

### APPLICATION

- Upholstery
- Automotive
- Insulation
- Cabinet backs
- Small furniture
- Picture frames
- Light trim and moulding
- Reinforce construction
- Tectonic floor
- Drywall and partition
- Steel to concrete
- Steel to steel

### FEATURES

- Comfortable handle with rubber
- Strong and light-weight die cast housing
- Fast and easy down loading





## Fine Wire Stapler

Model No: 8016A1



Model No	8016A1
L x W x H	216x43x148 mm
Weight	0.9 kgs
Gauge	21 GA
Crown (A)	12.7 mm
Width(B)xThickness(C)	0.6x0.9 mm
Length(D)	4~16 mm
Working Pressure	60~90 psi
Capacity	145 pcs

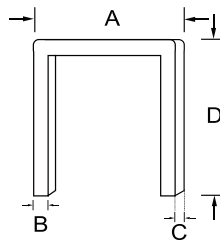

### APPLICATION

- Furniture and wooden cases manufacturers, decoration and other kind of fastening work

### FEATURES

- Similar to BeA's 80 series stapler
- Compact and lightweight design prevents arm fatigue for user
- Trigger lock as a safety precaution while tool is not in use
- Ergonomic comfort handgrip provides a firm grip for user
- Convenient drop-in loading provides quick fastener reloading

### OPTION

- Long Magazine
- Long Nose
- Safety
- Long Magazine and Safety
- Long Nose and Safety
- Automatic
- Long Magazine and Automatic

## Fine Wire Staplers

Model No: 413J, 1013J, 1014F



Model No	413J	1013J	1014F
L x W x H	145x45x210 mm		
Weight	0.85 kgs		
Gauge	20 GA	20 GA	22 GA
Crown(A)	4 mm	4 mm	10 mm
Width(B)xThickness(C)	1.2x0.6 mm	1.2x0.6 mm	0.7x0.5 mm
Length(D)	4~13 mm	4~13 mm	4~14 mm
Capacity	100 pcs	100 pcs	200 pcs

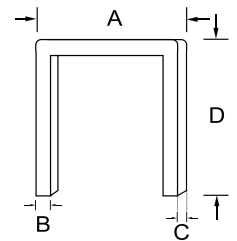

### APPLICATION

- Upholstery
- Wooden cases
- Paper board
- Toys
- Window shade
- Cabinet backs
- Furniture backs
- Shoemaking
- Carpet laying
- Luggage

### FEATURES

- Bottom load, jam free magazine
- Slim long nose for easy, precise staple placement
- Comfortable rubber grip



## Fine Wire Staplers

Model No: 425J, 1025J



Model No	425J	1025J
L x W x H	250x58x185 mm	
Weight	1.23 kgs	
Gauge	20 GA	
Crown(A)	4 mm	10 mm
Width(B)xThickness(C)	1.2x0.6 mm	1.2x0.6 mm
Length(D)	10~25 mm	
Capacity	100 pcs	

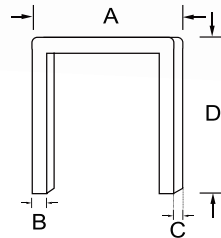

### APPLICATION

- Upholstery, furniture, bedding
- Door, window, trimming, picture frames, building components
- Cabinets, furniture, light wood assembly
- Siding, sheathing, paneling, fencing

### FEATURES

- 360° rotatable air deflector
- Bottom load, durable aluminum magazine
- Comfortable rubber grip
- Bump fire trigger
- Sequential trigger valve available
- Belt hook available

## Fine Wire Staplers

Model No: 1022J



Model No	1022J
L x W x H	250x55x174 mm
Weight	1.2 kgs
Gauge	20 GA
Crown(A)	10 mm
Width(B)xThickness(C)	1.2x0.6 mm
Length(D)	10~22 mm
Capacity	100 pcs

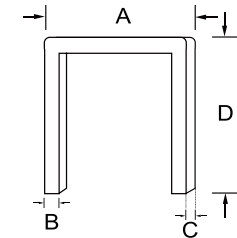

### APPLICATION

- Upholstery, furniture, bedding
- Door, window, trimming, picture frames, building components
- Cabinets, furniture, light wood assembly
- Siding, sheathing, paneling, fencing

### FEATURES

- Bottom load, jam free magazine
- Slim long nose for easy, precise staple placement
- Comfortable rubber grip



## Medium Wire Staplers

Model No: 9040A, 9240L



Model No	9040A	9240L
L x W x H	250x58x242 mm	
Weight	1.42 kgs	
Gauge	18 GA	
Crown(A)	5.7 mm	8.7 mm
Width(B)xThickness(C)	1.25x1.05 mm	1.25x1.00 mm
Length(D)	16~40 mm	
Capacity	100 pcs	

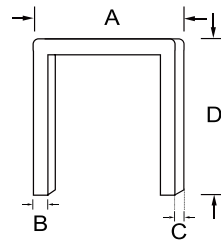

### APPLICATION

- Upholstery, furniture, bedding
- Cabinets, furniture, light wood assembly
- Packaging, crating, pallets
- Industrial, pre-fabricated housing

### FEATURES

- 360° rotatable air deflector
- Bottom load
- Light weight
- Well balanced

## Medium Wire Staplers

Model No: 9025, 9725, 9225, SM25, 4025

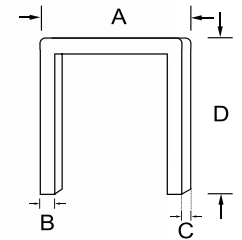

Model No	9025	9725	9225	SM25	4025
L x W x H	250x58x185 mm				
Weight	1.21 kgs				
Gauge	18 GA	21 GA	18 GA	18 GA	21 GA
Crown(A)	5.7 mm	4.5 mm	8.7 mm	10 mm	5 mm
Width(B)xThickness(C)	1.25x1.06 mm	0.95x0.7 mm	1.25x1 mm	1.1x1.25 mm	0.9x0.8 mm
Length(D)	10~25 mm				
Capacity	100 pcs				

### APPLICATION

- Framing, joiner
- Upholstery, furniture, bedding
- Door, window, trimming, picture frames, building components
- Cabinets, furniture, light wood assembly
- Siding, sheathing, paneling, fencing
- Industrial, Pre-Fabricated housing

### FEATURES

- 360° rotatable air deflector
- Bottom load, durable aluminum magazine
- Comfortable rubber grip
- Bump fire trigger
- Sequential trigger valve available
- Belt hook available



**Medium Wire Staplers**  
Model No: 9040H, 9240H



Model No	9040H	9240H
L x W x H	317x72x258 mm	
Weight	1.78 kgs	
Gauge	18 GA	
Crown(A)	5.7 mm	8.7 mm
Width(B)xThickness(C)	1.25x1.05 mm	1.25x1.00 mm
Length(D)	16~40 mm	
Capacity	100 pcs	

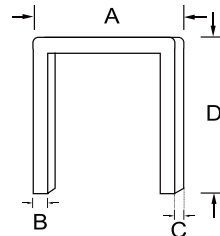

**APPLICATION**

- Upholstery, furniture, bedding
- Cabinets, furniture, light wood assembly
- Packaging, crating, pallets
- Industrial, Pre-Fabricated housing

**FEATURES**

- Heavy duty version for hardwood applications
- 360° rotatable air deflector
- Bottom load, durable aluminum magazine
- Comfortable rubber grip
- Bump fire trigger



## 18GA. Staplers

Model No: 9232A1



Model No	9232A1
L x W x H	210x50x225 mm
Weight	1.3 kgs
Gauge	18 GA
Crown(A)	8.7 mm
Width(B)xThickness(C)	1.25x1.00 mm
Length(D)	10~32 mm
Capacity	100 pcs
Working Pressure	70~100 psi

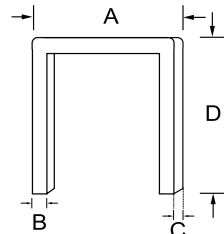

### APPLICATION

- Furniture manufacturing
- Prefabricated(ex: garden, furniture)
- Kitchen and shop racks
- Doors and windows
- Packaging(ex: boxes, matchboarding)

### FEATURES

- Powerful motor allows penetration through the hardest materials
- Lightweight die cast body prevents arm fatigue during prolong use
- Convenient depth of drive dial allows precise staple settings
- Quick release nose cover provides easy access for clearing jams
- Ergonomic comfort handgrip provides a firm grip for user
- High fastener capacity reduces frequency for reloading
- Durable driver and o-ring assembly

## 18GA. Staplers

Model No: 9040A1



Model No	9040A1
L x W x H	254x58x235 mm
Weight	1.2 kgs
Gauge	18 GA
Crown(A)	5.8 mm
Width(B)xThickness(C)	1.25x1.00 mm
Length(D)	13~40 mm
Capacity	150 pcs
Working Pressure	70~100 psi

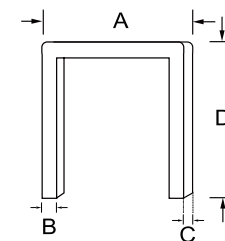

### APPLICATION

- Furniture manufacturing
- Prefabricated(ex: garden, furniture)
- Kitchen and shop racks
- Doors and windows
- Packaging(ex: boxes, matchboarding)

### FEATURES

- Powerful motor allows penetration through the hardest materials
- Lightweight die cast body prevents arm fatigue during prolong use
- Convenient depth of drive dial allows precise staple settings
- Quick release nose cover provides easy access for clearing jams
- Ergonomic comfort handgrip provides a firm grip for user
- High fastener capacity reduces frequency for reloading
- Durable driver and o-ring assembly



## 18GA. Staplers

Model No: 9032A1



Model No	9032A1
L x W x H	210x50x225 mm
Weight	1.3 kgs
Gauge	18 GA
Crown(A)	5.8 mm
Width(B)xThickness(C)	1.25x1.00 mm
Length(D)	10~32 mm
Capacity	100 pcs
Working Pressure	70~100 psi

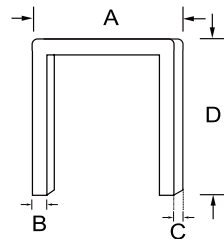

### APPLICATION

- Furniture manufacturing
- Prefabricated(ex: garden, furniture)
- Kitchen and shop racks
- Doors and windows
- Packaging(ex: boxes, matchboarding)

### FEATURES

- Powerful motor allows penetration through the hardest materials
- Lightweight die cast body prevents arm fatigue during prolong use
- Convenient depth of drive dial allows precise staple settings
- Quick release nose cover provides easy access for clearing jams
- Ergonomic comfort handgrip provides a firm grip for user
- High fastener capacity reduces frequency for reloading
- Durable driver and o-ring assembly

## 18GA. Staplers

Model No: 9240A1



Model No	9240A1
L x W x H	254x58x260 mm
Weight	1.3 kgs
Gauge	18 GA
Crown(A)	8.7 mm
Width(B)xThickness(C)	1.25x1.00 mm
Length(D)	16~40 mm
Capacity	100 pcs
Working Pressure	70~100 psi

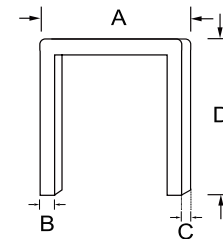

### APPLICATION

- Furniture manufacturing
- Prefabricated(ex: garden, furniture)
- Kitchen and shop racks
- Doors and windows
- Packaging(ex: boxes, matchboarding)

### FEATURES

- Powerful motor allows penetration through the hardest materials
- Lightweight die cast body prevents arm fatigue during prolong use
- Convenient depth of drive dial allows precise staple settings
- Quick release nose cover provides easy access for clearing jams
- Ergonomic comfort handgrip provides a firm grip for user
- High fastener capacity reduces frequency for reloading
- Durable driver and o-ring assembly



## Heavy Duty Staplers

Model No: 16964, 16864, 16764, 1664Q



Model No	16964	16864	16764	1664Q
L x W x H	380x95x310 mm			
Weight	2.76 kgs			
Gauge	16 GA	16 GA	16 GA	15 GA
Crown(A)	12.4 mm	11.1 mm	11.5 mm	11.3 mm
Width(B)xThickness(C)	1.65x1.4 mm	1.6x1.4 mm	1.6x1.4 mm	1.9x1.7 mm
Length(D)	25~64 mm			
Capacity	140 pcs			

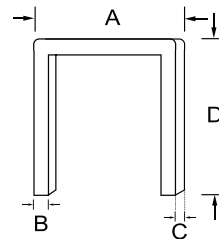

### APPLICATION

- Roofing, carpentry
- Framing, joiner
- Door, window, trimming, picture frames, building components
- Packaging, crating, pallets
- Industrial, pre-fabricated housing

### FEATURES

- Patented quick release nose cover
- 360° adjustable air deflector
- Heavy duty, well balanced
- Sequential fire trigger available

## Heavy Duty Staplers

Model No: 16951, 16851, 16751



Model No	16951	16851	16751
L x W x H	365x95x310 mm		
Weight	2.88 kgs		
Gauge	16 GA		
Crown(A)	12.4 mm	11.1 mm	11.5 mm
Width(B)xThickness(C)	1.65x1.4 mm	1.6x1.4 mm	1.6x1.4 mm
Length(D)	25~50 mm		
Capacity	140 pcs		

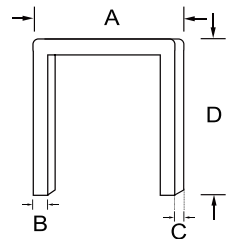

### APPLICATION

- Roofing, framing, packaging
- Door, window, trimming
- Pre-fabricated housing, carpenter, joiner
- Picture frames, pallets, crating
- Industrial, building components

### FEATURES

- Patented quick release nose cover
- 360° adjustable air deflector
- Heavy duty, well balanced
- Depth adjustment
- Dedicated bump fire trigger
- Sequential trigger available
- Top load long magazine



# 16 GA. Wide Crown Stapler

Model No: 2638SP



Model No	2638SP
L x W x H	359x70x257 mm
Weight	2.4 kgs
Gauge	16 GA
Crown(A)	26.4 mm
Width(B)xThickness(C)	1.6x1.4 mm
Length(D)	19~38 mm
Capacity	160 pcs

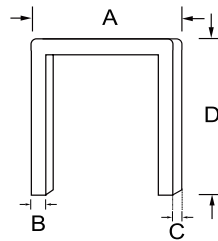

## APPLICATION

- Roofing, sheathing, wire lathe
- Framing, window & door manufacturing
- Pre-fabricated housing, trusses
- Pallets, crating

## FEATURES

- Patented quick release nose cover
- 360° adjustable air deflector
- Comfortable rubber grip
- Sequential fire trigger available
- Fast driving – one second 10 shots

**JUST SEND YOUR  
SAMPLES  
AT OUR COST !**



**VIM INTERNATIONAL ENTERPRISE CO., LTD.**





## 18 GA. Cap Stapler

Model No: M32PC

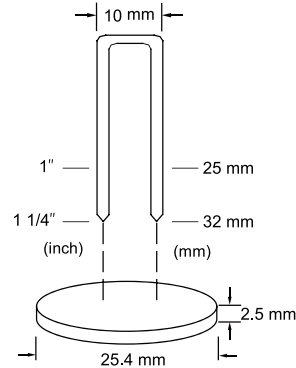

Model No	M32PC
L x W x H	225x130x270 mm
Weight	1.8 kgs
Gauge	18 GA
Wire Size	1.25x1.1 mm
Width	1.1 mm
Plastic Cap Size	25.4 mm
Fastener Range	25~32 mm

### APPLICATION

- Roofing felt
- Sheathing
- Modified or single-ply roof decks
- House wrap
- Insulation board and built-up

### FEATURES

- Lightweight design prevents arm fatigue for user
- Adjustable depth of drive
- Tool free adjustable exhaust
- Fast easy bottom loading
- Ergonomic comfort handgrip provides a firm grip on tool
- Available for bump and single fire
- Make cap stay on workpiece tightly



Nail Depth Adjustable Dial

## 21 GA. Cap Stapler

Model No: 8016WS

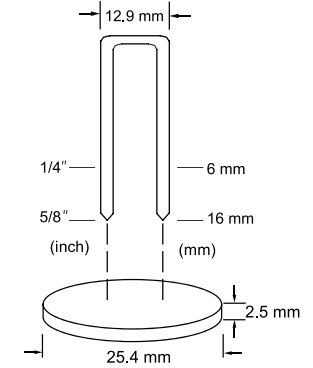

Model No	8016WS
L x W x H	220x125x280 mm
Weight	1.5 kgs
Gauge	21 GA
Wire Size	0.95x0.66 mm
Width	1.1 mm
Plastic Cap Size	25.4 mm
Fastener Range	6~16 mm

### APPLICATION

- House wrap
- Roofing felt
- Insulation board and built-up
- Modified or single-ply roof decks

### FEATURES

- Lightweight design prevents arm fatigue for user
- Fast easy bottom loading
- Ergonomic comfort handgrip provides a firm grip on tool
- Available for bump and single fire
- Make cap stay on workpiece tightly



## Roofing Stapler

Model No: 1638R



Model No	1638R
L x W x H	330x80x265 mm
Weight	2.42 kgs
Gauge	16 GA
Crown(A)	26.5 mm
Width(B)xThickness(C)	1.6x1.4 mm
Length(D)	12~38 mm
Capacity	140 pcs

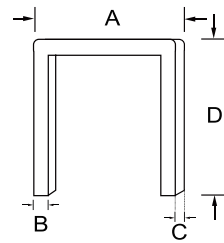

### APPLICATION

- Roofing, framing, packaging
- Door, window, trimming
- Pre-fabricated housing, carpenter, joiner
- Picture frames, pallets, crating
- Industrial, building componets

### FEATURES

- Patented quick release nose cover
- 360° adjustable air deflector
- Heavy duty, well balanced
- Sequential fire trigger available

## 15.5 GA Pneumatic Flooring Stapler

Model No: PF1250

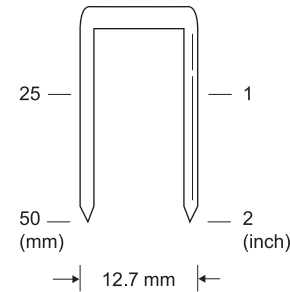

Model No	PF1250
L x W x H	378x439x79 mm
Weight	5.1 kgs
Gauge	15.5 GA
Crown	12.7 mm
Width x Thickness	1.90 x 1.60 mm
Length	25~50 mm
Load Capacity	92 staples
Operation Pressure	70~110 psi
Equivalent	Stanley Bostitch MIIIFS

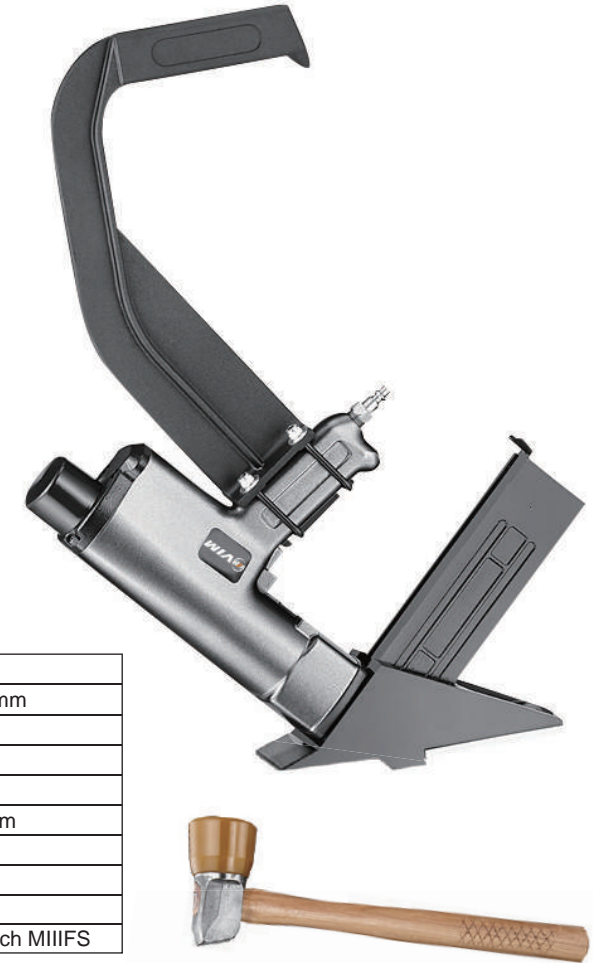

### APPLICATION

- Solid and engineered hardwood flooring installation
- Design for the installation of prefabricated Wood-Laminate flooring boards
- High-Speed fastening of hardwood flooring
- Secures the flooring at the proper angle and penetration

### FEATURES

- High-speed mallet-actuated pneumatic operation increases productivity
- Precisely drives staples at proper angle and depth
- Extra-wide composite base plate for stability
- Long-reach handle for added user comfort and control
- Replaceable soft face is specially formulated to protect delicate pre-finished flooring from damage





# Manual Carton Staplers

Model No: MCSH3518A~MCSH3522C



A Type



B Type



C Type

Type	A Type	B Type	C Type
L x W x H	390x115x295 mm	470x115x285 mm	400x115x285 mm
Weight	1.9 kgs	2.32 kgs	2.34 kgs

Model No	Crown(A)	Width(B)x Thickness(C)	Length(D)	Capacity
MCSH3518A/MCSH3518B/MCSH3518C	34.7 mm	0.9 x 2.3 mm	15,18 mm	100 pcs
MCSH3419A/MCSH3419B/MCSH3419C	34 mm	0.9 x 2.3 mm	16,19 mm	100 pcs
MCSH3218A/MCSH3218B/MCSH3218C	32 mm	0.9 x 1.9 mm	15,18 mm	100 pcs
MCSH743718A/MCSH743718B/MCSH743718C	34.5 mm	0.9 x 1.9 mm	15,18 mm	100 pcs
MCSH904018A/MCSH904018B/MCSH904018C	34.5 mm	0.9 x 2.3 mm	15,18 mm	100 pcs
MCSH3522A/MCSH3522B/MCSH3522C	34.7 mm	0.9 x 2.3 mm	18,22 mm	100 pcs

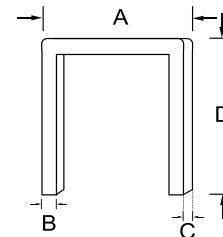

## APPLICATION

- For closing filled folding boxes made of strong double & triple corrugated cardboard

## FEATURES

- The hand Boxer represents always a good investment
- Low priced and sturdy
- It can seal thousands of boxes without any maintenance





# Manual Carton Staplers

Model No: MCS3518A-MCS3522D



A Type



B Type



C Type



D Type

Type	A Type	B Type	C Type	D Type
L x W x H	390x1115x295 mm	433x1115x285 mm	360x1115x295 mm	390x1115x295 mm
Weight	1.9 kgs	2.3 kgs	2.26 kgs	1.9 kgs

Model No	Crown(A)	Width(B)x Thickness(C)	Length(D)	Capacity
MCS3518A/MCS3518B/MCS3518C	34.7 mm	0.9 x 2.3 mm	15,18 mm	100 pcs
MCS3419A/MCS3419B/MCS3419C	34 mm	0.9 x 2.3 mm	16,19 mm	100 pcs
MCS3218A/MCS3218B/MCS3218C	32 mm	0.9 x 1.9 mm	15,18 mm	100 pcs
MCS743718A/MCS743718B/MCS743718C	34.5 mm	0.9 x 1.9 mm	15,18 mm	100 pcs
MCS904018A/MCS904018B/MCS904018C	34.5 mm	0.9 x 2.3 mm	15,18 mm	100 pcs
MCS3522A/MCS3522B/MCS3522C	34.7 mm	0.9 x 2.3 mm	18,22 mm	100 pcs

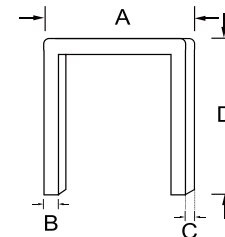

## APPLICATION

- For closing filled folding boxes made of strong double & triple corrugated cardboard

## FEATURES

- The hand Boxer represents always a good investment
- Low priced and sturdy
- It can seal thousands of boxes without any maintenance



# Pneumatic Coil Carton Staplers

Model No: PCIRR3218,PCIGR3218,PCIRR3222,PCS3418,PCT3218

L x W x H	233x115x230 mm
Weight	2.38 kgs
Working Pressure	70~100 psi



## APPLICATION

- Small to medium box closure
- Ideal for overlap cartons and five panel folders
- Ideal for replacing or enhancing glue system

## FEATURES

- Coll feed carton top sealer
- Drives 1000 wide crown stapler
- Combines light weight and balance for fast
- Efficient operation
- Full cycle action for maximum speed
- Quick release to prevent jams and adjustment of tightness and depth of clinch

## Carton Closing Roll Staples

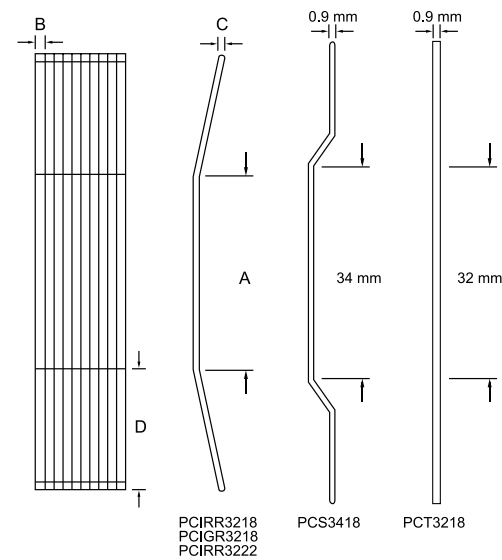

Model No	Crown(A)	Staple Series	Width(B)xThickness(C)	Length(D)	Capacity
PCIRR3218	32 mm	I Series	0.9 x 1.9 mm	15, 18 mm	1000 pcs
PCIGR3218	32 mm	I Series	0.9 x 2.3 mm	15, 18 mm	1000 pcs
PCIRR3222	32 mm	I Series	0.9 x 2.3 mm	18, 22 mm	1000 pcs
PCS3418	34 mm	S Series	0.9 x 1.9 mm	15, 18 mm	1000 pcs
PCT3218	32 mm	T Series	0.9 x 1.9 mm	15, 18 mm	1000 pcs



# Pneumatic Carton Staplers

Model No: PCS3518A~PCS3522C



A Type

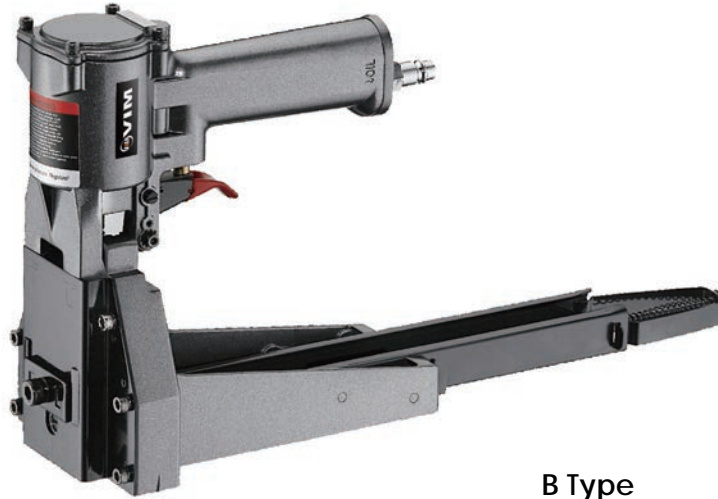

B Type



C Type

Type	A Type	B Type	C Type
L x W x H	415x115x220 mm	415x115x220 mm	320x115x225 mm
Weight	2.65 kgs	2.65 kgs	2.48 kgs
Working Pressure	70~100 psi	70~100 psi	70~100 psi



Model No	Crown(A)	Width(B)x Thickness(C)	Length(D)	Capacity
PCS3518A/PCS3518B/PCS3518C	34.7 mm	0.9 x 2.3 mm	15,18 mm	100 pcs
PCS3419A/PCS3419B/PCS3419C	34 mm	0.9 x 2.3 mm	16,19 mm	100 pcs
PCS3218A/PCS3218B/PCS3218C	32 mm	0.9 x 1.9 mm	15,18 mm	100 pcs
PCS743718A/PCS743718B/PCS743718C	34.5 mm	0.9 x 1.9 mm	15,18 mm	100 pcs
PCS904018A/PCS904018B/PCS904018C	34.5 mm	0.9 x 2.3 mm	15,18 mm	100 pcs
PCS3522A/PCS3522B/PCS3522C	34.7 mm	0.9 x 2.3 mm	18,22 mm	100 pcs

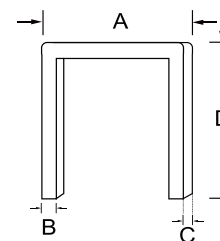

## APPLICATION

- For closing filled folding boxes made of strong double & triple corrugated cardboard

## FEATURES

- The air boxer is the most suitable machine when high speed and efficiency are required
- It is possible to adjust the clinching of the staple as well as its penetration
- Handy and light
- The air boxer reduces a minimum operator fatigue



## Pneumatic Jumbo Carton Staplers

Model No: JS3228,JS3235,JS3238

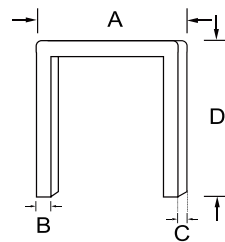

L x W x H	360x174x335 mm
Weight	6 kgs
Capacity	100 pcs
Working Pressure	70~100 psi

Model No	Crown(A)	Width(B)x Thickness(C)	Length(D)	Shape Of Staples	Position	Threading Depth
JS3228	32 mm	1.4 x 2.3 mm	25, 28 mm		5, 4	15 mm
JS3235	32 mm	1.4 x 2.3 mm	32, 35 mm		5, 4	18 mm
JS3238	32 mm	1.4 x 2.3 mm	38 mm		6	24 mm

### APPLICATION

- For closing filled folding boxes made of strong double & triple corrugated cardboard
- Suitable for staples with 25mm~38mm leg length
- For cartons with 15mm~24 mm total thickness

### FEATURES

- Stapler can be adjusted to different penetration depths

## Pneumatic Jumbo Carton Staplers

Model No: JS3222A,JS3222B

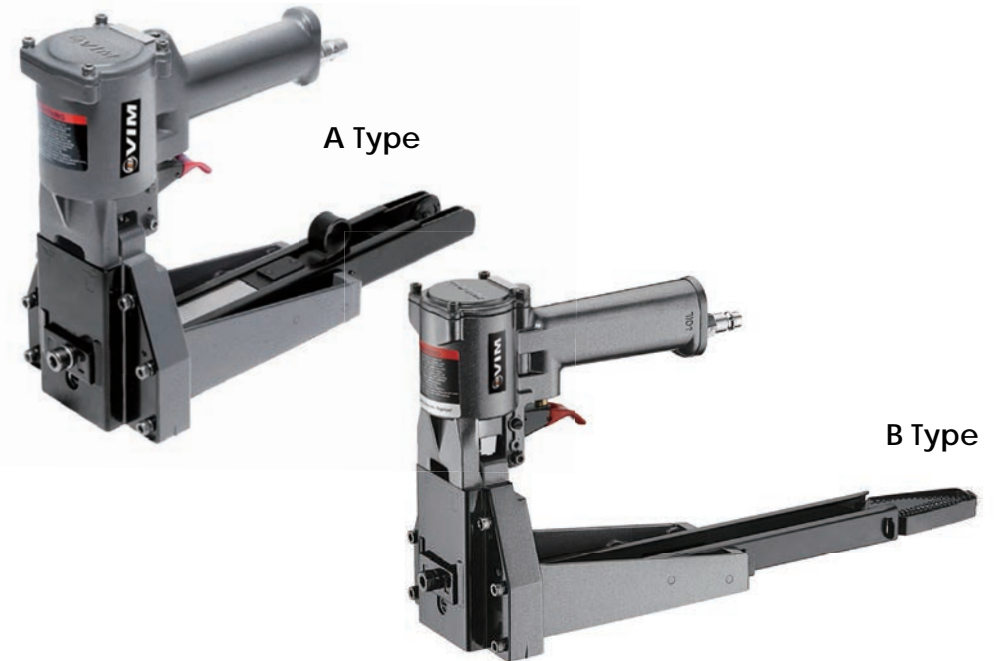

Type	A Type	B Type
L x W x H	320x115x225 mm	415x115x220 mm
Weight	2.48 kgs	2.65 kgs
Working Pressure	70~100 psi	70~100 psi

Model No	Crown(A)	Width(B)x Thickness(C)	Length(D)	Capacity
JS3222A	32 mm	1.4 x 2.3 mm	22 mm	100 pcs
JS3222B	32 mm	1.4 x 2.3 mm	22 mm	100 pcs

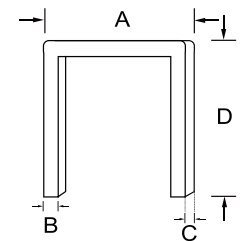

### APPLICATION

- For closing filled folding boxes made of strong double & triple corrugated cardboard

### FEATURES

- Handing and light
- The stapler reduces to a minimum operator fatigue





# Hand Free Coil Carton Staplers

Model No: HCSRR3218,HCSGR3218,HCSRR3222,HCSS3418,HCST3218



Carton Closing Roll Staples



I Series



S Series



T Series

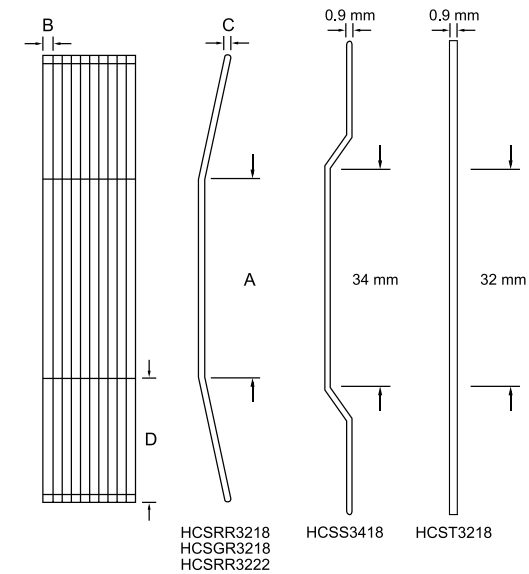

## APPLICATION

- Small to medium box closure
- Ideal for overlap cartons and five panel folders
- Ideal for replacing or enhancing glue system

## FEATURES

- Carton contact activated trip allows operator to both hands to maneuver carton for side strike stapling

Model No	L x W x H	Crown(A)	Staple Series	Width(B)x Thickness(C)	Length(D)	Capacity
HCSRR3218	280x120x350 mm	32 mm	I Series	0.9 x 1.9 mm	15, 18 mm	1000 pcs
HCSGR3218		32 mm	I Series	0.9 x 2.3 mm	15, 18 mm	1000 pcs
HCSRR3222		32 mm	I Series	0.9 x 2.3 mm	18, 22 mm	1000 pcs
HCSS3418		34 mm	S Series	0.9 x 1.9 mm	15, 18 mm	1000 pcs
HCST3218		32 mm	T Series	0.9 x 1.9 mm	15, 18 mm	1000 pcs





# Hand Free Coil Carton Stapler Switch Bracket

Model No: HCSRR3218B, HCSGR3218B, HCSRR3222B, HCSS3418B, HCST3218B



Carton Closing Roll Staples



I Series



S Series



T Series

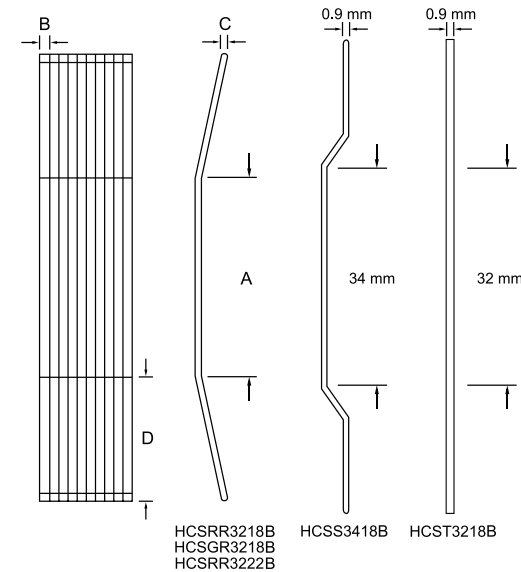

HCSRR3218B  
HCSGR3218B  
HCSRR3222B

HCSS3418B

HCST3218B

## APPLICATION

- Small to medium box closure
- Ideal for overlap cartons and five panel folders
- Ideal for replacing or enhancing glue system

## FEATURES

- Carton contact activated trip allows operator to both hands to maneuver carton for side strike stapling

Model No	L x W x H	Crown(A)	Staple Series	Width(B)x Thickness(C)	Length(D)	Capacity
HCSRR3218B	530x200x500 mm	32 mm	I Series	0.9 x 1.9 mm	15, 18 mm	1000 pcs
HCSGR3218B		32 mm	I Series	0.9 x 2.3 mm	15, 18 mm	1000 pcs
HCSRR3222B		32 mm	I Series	0.9 x 2.3 mm	18, 22 mm	1000 pcs
HCSS3418B		34 mm	S Series	0.9 x 1.9 mm	15, 18 mm	1000 pcs
HCST3218B		32 mm	T Series	0.9 x 1.9 mm	15, 18 mm	1000 pcs



## Foot Operated Bottomer

Model No: FB3522, FB3422, FB3222, FB743718, FB904022, FB1618

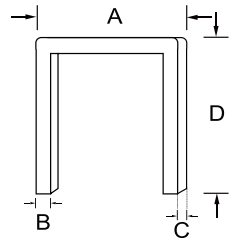

L x W x H	910x600x1245 mm
Weight	26.8 kgs
Working Height	950 mm
Throat Depth	320 mm

### Foot Operated Bottomer Staplers

Model No	Crown(A)	Width(B)xThickness(C)	Length(D)	Capacity
FB3522	34.7 mm	0.9 x 2.3 mm	15, 18, 22 mm	200 pcs
FB3422	34 mm	0.9 x 2.3 mm	16, 19, 22 mm	200 pcs
FB3222	32 mm	0.9 x 1.9 mm	15, 18, 22 mm	200 pcs
FB743718	34.5 mm	0.9 x 1.9 mm	15, 18 mm	200 pcs
FB904022	34.5 mm	0.9 x 2.3 mm	15, 18, 22 mm	200 pcs
FB1618	16 mm	0.6 x 1.8 mm	8, 15, 18, 22 mm	200 pcs

### APPLICATION FEATURES

- Bottom stapling
- Transport packing
- The mechanical bottomer satisfy the simplest exigencies in cardboard bottom sealing
- Its use is filled in different locations and limited quantities
- Easy staple load design for fast staple loading
- Short ergonomic foot pedal designed for speed and easy actuation
- Robust with steel tubing frame and wearing parts of hardened steel

## Foot Operated Bottomer

Model No: HFB3522, HFB3222

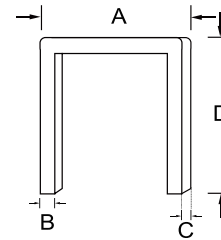

L x W x H	979x732x1315 mm
Weight	44.26 kgs
Working Height	1085 mm
Throat Depth	394 mm

### Foot Operated Bottomer Staplers

Model No	Crown(A)	Width(B)xThickness(C)	Length(D)	Capacity
HFB3522	34.7 mm	0.9 x 2.3 mm	15, 18, 22 mm	300 pcs
HFB3422	34 mm	0.9 x 1.9 mm	15, 18, 22 mm	300 pcs

### APPLICATION FEATURES

- Bottom stapling
- Transport packing
- The mechanical bottomer satisfy the simplest exigencies in cardboard bottom sealing
- Its use is filled in different locations and limited quantities
- Easy staple load design for fast staple loading
- Short ergonomic foot pedal designed for speed and easy actuation
- Robust with steel tubing frame and wearing parts of hardened steel



## Foot Operated Bottomer

Model No: HFB5315

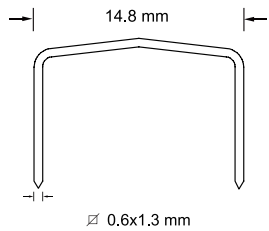

L x W x H	930x732x1280 mm
Weight	44.26 kgs
Working Height	1085 mm
Throat Depth	394 mm

Model No	Crown	Width x Thickness	Length	Capacity
HFB5315	14.8 mm	0.6 x 1.3 mm	6, 9, 12, 15 mm	315 pcs

### APPLICATION

- Bottom stapling
- Transport packing

### FEATURES

- The mechanical bottomer satisfy the simplest exigencies in cardboard bottom sealing
- Its use is filled in different locations and limited quantities
- Easy staple load design for fast staple loading
- Short ergonomic foot pedal designed for speed and easy actuation
- Robust with steel tubing frame and wearing parts of hardened steel

## Foot Operated Side Bottomer

Model No: FSB3522, FSB3422, FSB3222, FSB743718, FSB904022, FSB1618

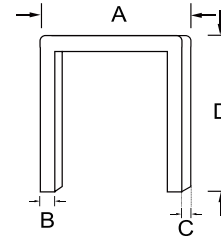

L x W x H	910x600x1245 mm
Weight	24.6 kgs
Working Height	950 mm
Throat Depth	320 mm

### Foot Operated Side Bottomers

Model No	Crown(A)	Width(B)xThickness(C)	Length(D)	Capacity
FSB3522	34.7 mm	0.9 x 2.3 mm	15, 18, 22 mm	200 pcs
FSB3422	34 mm	0.9 x 2.3 mm	16, 19, 22 mm	200 pcs
FSB3222	32 mm	0.9 x 1.9 mm	15, 18, 22 mm	200 pcs
FSB743718	34.5 mm	0.9 x 1.9 mm	15, 18 mm	200 pcs
FSB904022	34.5 mm	0.9 x 2.3 mm	15, 18, 22 mm	200 pcs
FSB1618	16 mm	0.6 x 1.8 mm	8, 15, 18, 22 mm	200 pcs

### APPLICATION

- Bottom stapling
- Transport packing

### FEATURES

- When the production output requires sealing of 50 to 100 carton bottoms per hour
- The use of a pneumatic bottomer is advisable
- This model is equipped with a safety foot pedal
- Easy Staple load design for fast staple loading
- Short ergonomic foot pedal designed for speed and easy actuation
- Robust with steel tubing frame and wearing parts of hardened steel



## Foot Operated Side Bottomer

Model No: HFSB3522,HFSB3222

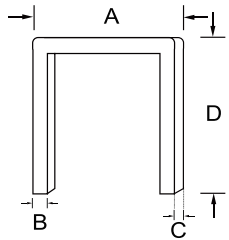

L x W x H	979x732x1315 mm
Weight	44.26 kgs
Working Height	1085 mm
Throat Depth	394 mm

### Foot Operated Side Bottomer Staplers

Model No	Crown(A)	Width(B)xThickness(C)	Length(D)	Capacity
HFSB3522	34.7 mm	0.9 x 2.3 mm	15, 18, 22 mm	200 pcs
HFSB3222	32 mm	0.9 x 1.9 mm	15, 18, 22 mm	200 pcs

### APPLICATION

- Bottom stapling
- Transport packing

### FEATURES

- When the production output requires sealing of 50 to 100 caton bottoms per hour
- The use of a pneumatic bottomer is advisable
- This model is equipped with a safety foot pedal
- Easy Staple load design for fast staple loading
- Short ergonomic foot pedal designed for speed and easy actuation
- Robust with steel tubing frame and wearing parts of hardened steel

## Foot Operated Side Bottomer

Model No: HFSB5315

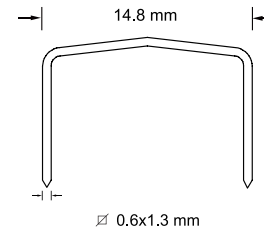

L x W x H	930x732x1315 mm
Weight	44.26 kgs
Working Height	1085 mm
Throat Depth	394 mm

Model No	Crown	Width x Thickness	Length	Capacity
HFSB5315	14.8 mm	0.6 x 1.3 mm	6, 9, 12, 15 mm	315 pcs

### APPLICATION

- Bottom stapling
- Transport packing

### FEATURES

- When the production output requires sealing of 50 to 100 caton bottoms per hour
- The use of a pneumatic bottomer is advisable
- This model is equipped with a safety foot pedal
- Easy Staple load design for fast staple loading
- Short ergonomic foot pedal designed for speed and easy actuation
- Robust with steel tubing frame and wearing parts of hardened steel



## Pneumatic Side Bottomer

Model No: PSB3522M, PSB3422M, PSB3222M, PSB743718M, PSB904022M

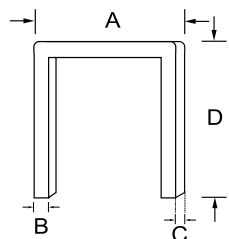

L x W x H	830x600x1550 mm
Weight	30 kgs
Working Height	1250 mm
Throat Depth	320 mm
Carton Height	930/1250/1520 mm

Pneumatic Side Bottomers

Model No	Crown(A)	Width(B)xThickness(C)	Length(D)	Capacity	Working Pressure
PSB3522M	34.7 mm	0.9 x 2.3 mm	15, 18, 22 mm	200 pcs	70~90 psi
PSB3422M	34 mm	0.9 x 2.3 mm	16, 19, 22 mm	200 pcs	70~90 psi
PSB3222M	32 mm	0.9 x 1.9 mm	15, 18, 22 mm	200 pcs	70~90 psi
PSB743718M	34.5 mm	0.9 x 1.9 mm	15, 18 mm	200 pcs	70~90 psi
PSB904022M	34.5 mm	0.9 x 2.3 mm	15, 18, 22 mm	200 pcs	70~90 psi

### APPLICATION

- Bottom stapling
- Transport packing

### FEATURES

- When the production output requires sealing of 0 to 100 caton bottoms per hour
- The use of a pneumatic bottomer is advisable
- This model is equipped with a safety foot pedal
- Easy Staple load design for fast staple loading
- Short ergonomic foot pedal designed for speed and easy actuation
- Robust with steel tubing frame and wearing parts of hardened steel

## Pneumatic Side Bottomer

Model No: PSB3522L, PSB3422L, PSB3222L, PSB743718L, PSB904022L

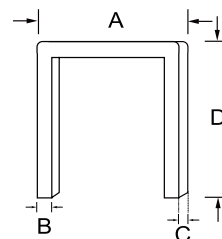

L x W x H	830x600x1850 mm
Weight	32 kgs
Working Height	1520 mm
Throat Depth	320 mm
Carton Height	930/1250/1520 mm

Pneumatic Side Bottomers

Model No	Crown(A)	Width(B)xThickness(C)	Length(D)	Capacity	Working Pressure
PSB3522L	34.7 mm	0.9 x 2.3 mm	15, 18, 22 mm	200 pcs	70~90 psi
PSB3422L	34 mm	0.9 x 2.3 mm	16, 19, 22 mm	200 pcs	70~90 psi
PSB3222L	32 mm	0.9 x 1.9 mm	15, 18, 22 mm	200 pcs	70~90 psi
PSB743718L	34.5 mm	0.9 x 1.9 mm	15, 18 mm	200 pcs	70~90 psi
PSB904022L	34.5 mm	0.9 x 2.3 mm	15, 18, 22 mm	200 pcs	70~90 psi

### APPLICATION

- Bottom stapling
- Transport packing

### FEATURES

- When the production output requires sealing of 0 to 100 caton bottoms per hour
- The use of a pneumatic bottomer is advisable
- This model is equipped with a safety foot pedal
- Easy Staple load design for fast staple loading
- Short ergonomic foot pedal designed for speed and easy actuation
- Robust with steel tubing frame and wearing parts of hardened steel



## Pneumatic Side Bottomer

Model No: HPSB3522, HPSB3222

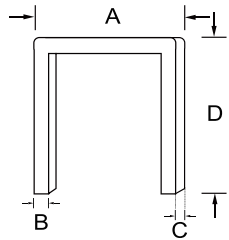

L x W x H	985x732x1360 mm
Weight	46.33 kgs
Working Height	1085 mm
Throat Depth	394 mm
Carton Height	1085 mm

Pneumatic Side Bottomer Staplers

Model No	Crown(A)	Width(B)xThickness(C)	Length(D)	Capacity	Working Pressure
HPSB3522	34.7 mm	0.9 x 2.3 mm	15, 18, 22 mm	300 pcs	70~90 psi
HPSB3222	32 mm	0.9 x 1.9 mm	15, 18, 22 mm	300 pcs	70~90 psi

### APPLICATION

- Bottom stapling
- Transport packing

### FEATURES

- When the production output requires sealing of 0 to 100 carton bottoms per hour
- The use of a pneumatic bottomer is advisable
- This model is equipped with a safety foot pedal
- Easy Staple load design for fast staple loading
- Short ergonomic foot pedal designed for speed and easy actuation
- Robust with steel tubing frame and wearing parts of hardened steel

## Pneumatic Side Bottomer

Model No: HPSB5315

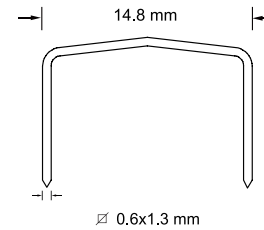

L x W x H	985x732x1360 mm
Weight	46.33 kgs
Working Height	1085 mm
Throat Depth	394 mm

Model No	Crown	Width x Thickness	Length	Capacity
HPSB5315	14.8 mm	0.6 x 1.3 mm	6, 9, 12, 15 mm	315 pcs

### APPLICATION

- Bottom stapling
- Transport packing

### FEATURES

- When the production output requires sealing of 0 to 100 carton bottoms per hour
- The use of a pneumatic bottomer is advisable
- This model is equipped with a safety foot pedal
- Easy Staple load design for fast staple loading
- Short ergonomic foot pedal designed for speed and easy actuation
- Robust with steel tubing frame and wearing parts of hardened steel



# Pneumatic Side Bottomer

Model No: PSB120,PSB150,PSB170,PSB230

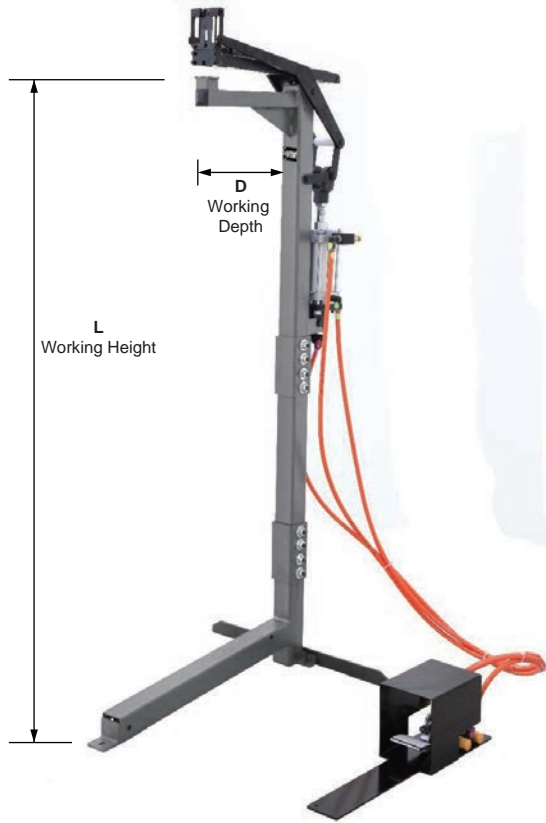

### APPLICATION:



L x W x H	735x600x1620 mm
Weight	33.3 kgs
Air Pressure	5~7 kgs/cm <sup>2</sup>

### APPLICATION

- Adjustable height pneumatic side bottomer to help you with stapling large carton lid and bottoms as well as storing itself

### FEATURES

- Depth and working height can be adjustable
- The use of a pneumatic bottomer is advisable
- The model is equipped with a safety foot pedal
- Easy Staple load design for fast staple loading
- Short ergonomic foot pedal designed for speed and easy actuation
- Robust with steel tubing frame and wearing parts of hardened steel

### Available Staplers

Model No	Crown(A)	Width(B)xThickness(C)	Length(D)	Working Height	Working Depth
PSB12035/PSB15035/PSB17035/PSB23035	34.7 mm	0.9 x 2.3 mm	15, 18, 22 mm	1200/1500/1700/2300 mm	310 mm
PSB12032/PSB15032/PSB17032/PSB23032	34 mm	0.9 x 2.3 mm	16, 19, 22 mm	1200/1500/1700/2300 mm	310 mm
PSB12034/PSB15034/PSB17034/PSB23034	32 mm	0.9 x 1.9 mm	15, 18, 22 mm	1200/1500/1700/2300 mm	310 mm
PSB1207437/PSB1507437/PSB1707437/PSB2307437	34.5 mm	0.9 x 1.9 mm	15, 18 mm	1200/1500/1700/2300 mm	310 mm
PSB1209040/PSB1509040/PSB1709040/PSB2309040	34.5 mm	0.9 x 2.3 mm	15, 18, 22 mm	1200/1500/1700/2300 mm	310 mm
PSB12016/PSB15016/PSB17016/PSB23016	16 mm	0.6 x 1.8 mm	8, 15, 18, 22 mm	1200/1500/1700/2300 mm	310 mm

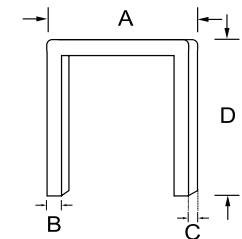

## Pneumatic Side Bottomer

Model No: PSB3522S, PSB3422S, PSB3222S, PSB743718S, PSB904022S, PSB1618S

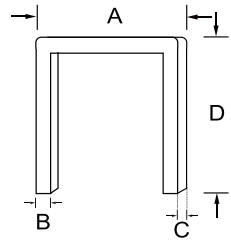

L x W x H	830x600x1245 mm
Weight	27 kgs
Working Height	930 mm
Throat Depth	320 mm
Working Pressure	70~90 psi

Pneumatic Side Bottomers

Model No	Crown(A)	Width(B)xThickness(C)	Length(D)	Capacity	Carton Height
PSB3522S	34.7 mm	0.9 x 2.3 mm	15, 18, 22 mm	200 pcs	930/1250/1520 mm
PSB3422S	34 mm	0.9 x 2.3 mm	16, 19, 22 mm	200 pcs	930/1250/1520 mm
PSB3222S	32 mm	0.9 x 1.9 mm	15, 18, 22 mm	200 pcs	930/1250/1520 mm
PSB743718S	34.5 mm	0.9 x 1.9 mm	15, 18 mm	200 pcs	930/1250/1520 mm
PSB904022S	34.5 mm	0.9 x 2.3 mm	15, 18, 22 mm	200 pcs	930/1250/1520 mm
PSB1618S	16 mm	0.6 x 1.8 mm	8, 15, 18, 22 mm	200 pcs	930 mm

### APPLICATION

- Bottom stapling
- Transport packing

### FEATURES

- When the production output requires sealing of 0 to 100 carton bottoms per hour
- The use of a pneumatic bottomer is advisable
- This model is equipped with a safety foot pedal
- Easy Staple load design for fast staple loading
- Short ergonomic foot pedal designed for speed and easy actuation
- Robust with steel tubing frame and wearing parts of hardened steel

## Pneumatic Side Bottomer

Model No: HPB5315

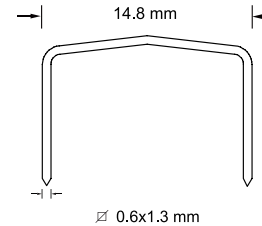

L x W x H	985x732x1360 mm
Weight	46.33 kgs
Working Height	1085 mm
Throat Depth	394 mm
Working Pressure	70~90 psi

Model No	Crown	Width x Thickness	Length	Capacity
HPB5315	14.8 mm	0.6 x 1.3 mm	6, 9, 12, 15 mm	315 pcs

### APPLICATION

- Bottom stapling
- Transport packing

### FEATURES

- When the production output requires sealing of 50 to 100 carton bottoms per hour
- The use of a pneumatic bottomer is advisable
- This model is equipped with a safety foot pedal
- Easy Staple load design for fast staple loading
- Short ergonomic foot pedal designed for speed and easy actuation
- Robust with steel tubing frame and wearing parts of hardened steel





## Pneumatic Bottomer

Model No: PB3522, PB3422, PB3222, PB743718, PB904022, PB1618

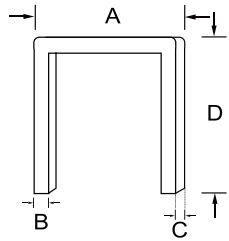

L x W x H	830x600x1245 mm
Weight	29.3 kgs
Working Height	950 mm
Throat Depth	320 mm
Working Pressure	70~90 psi

### Pneumatic Bottomers

Model No	Crown(A)	Width(B)xThickness(C)	Length(D)	Capacity
PB3522	34.7 mm	0.9 x 2.3 mm	15, 18, 22 mm	200 pcs
PB3422	34 mm	0.9 x 2.3 mm	16, 19, 22 mm	200 pcs
PB3222	32 mm	0.9 x 1.9 mm	15, 18, 22 mm	200 pcs
PB743718	34.5 mm	0.9 x 1.9 mm	15, 18 mm	200 pcs
PB904022	34.5 mm	0.9 x 2.3 mm	15, 18, 22 mm	200 pcs
PB1618	16 mm	0.6 x 1.8 mm	8, 15, 18, 22 mm	200 pcs

### APPLICATION

- Bottom stapling
- Transport packing

### FEATURES

- When the production output requires sealing of 50 to 100 caton bottoms per hour
- The use of a pneumatic bottomer is advisable
- This model is equipped with a safety foot pedal
- Easy Staple load design for fast staple loading
- Short ergonomic foot pedal designed for speed and easy actuation
- Robust with steel tubing frame and wearing parts of hardened steel

## Pneumatic Bottomer

Model No: HPB3522, HPB3222

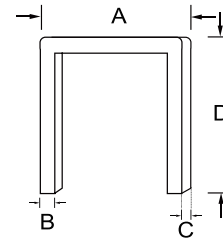

L x W x H	985x732x1360 mm
Weight	46.33 kgs
Working Height	1085 mm
Throat Depth	394 mm
Working Pressure	70~90 psi

### Heavy Duty Pneumatic Bottomers

Model No	Crown	Width x Thickness	Length	Capacity
HPB3522	34.7 mm	0.9 x 2.3 mm	15, 18, 22 mm	300 pcs
HPB3222	32 mm	0.9 x 1.9 mm	15, 18, 22 mm	300 pcs

### APPLICATION

- Bottom stapling
- Transport packing

### FEATURES

- When the production output requires sealing of 50 to 100 caton bottoms per hour
- The use of a pneumatic bottomer is advisable
- This model is equipped with a safety foot pedal
- Easy Staple load design for fast staple loading
- Short ergonomic foot pedal designed for speed and easy actuation
- Robust with steel tubing frame and wearing parts of hardened steel



## Mechanical Side Bottomer

Model No: MSB1655

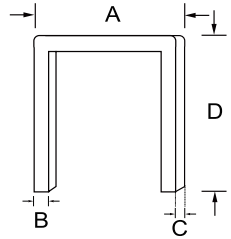

L x W x H	945x732x1291 mm
Weight	52.6 kgs
Working Height	1115 mm
Working Depth	559 mm

Model No	Crown(A)	Width(B)xThickness(C)	Length(D)
MSB1655	16 mm	0.59 x 1.8 mm	8, 12, 15, 18 mm

### APPLICATION

- Bottom stapling
- Transport packing

### FEATURES

- This model is equipped with a safety foot pedal
- Easy Staple load design for fast staple loading
- Short ergonomic foot pedal designed for speed and easy actuation
- Robust with steel tubing frame and wearing parts of hardened steel

## Mechanical Side Bottomer

Model No: MSB1675

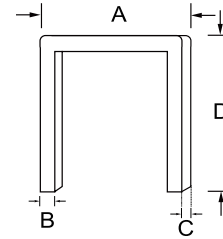

L x W x H	990x732x1328 mm
Weight	70.4 kgs
Working Height	1153 mm
Working Depth	759 mm

Model No	Crown(A)	Width(B)xThickness(C)	Length(D)
MSB1675	16 mm	0.59 x 1.8 mm	8, 12, 15, 18 mm

### APPLICATION

- Bottom stapling
- Transport packing

### FEATURES

- This model is equipped with a safety foot pedal
- Easy Staple load design for fast staple loading
- Short ergonomic foot pedal designed for speed and easy actuation
- Robust with steel tubing frame and wearing parts of hardened steel



# Mattress Staplers

Model No: MSD1619D, MS1619S, MS1625D, MS1625S

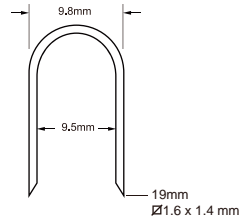

MS1619D,MS1619S

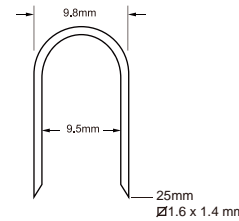

MS1625D,MS1625S

## APPLICATION

- Attaching spring to box frame

## FEATURES

- Pneumatic stapler for driving staples into hard to reach places such as bottoms of coil springs
- Available in double staple fire version

	Double Shooting Type		Single Shooting Type	
	MS1619D	MS1625D	MS1619S	MS1625S
Model No	MS1619D	MS1625D	MS1619S	MS1625S
L x W x H (mm)	445x46x900	445x46x900	445x46x900	445x46x900
Weight (kgs)	3	3	3	3
Gauge	16 GA	16 GA	16 GA	16 GA
Staples Crown	9.8 mm / 9.5 mm	9.8 mm / 9.5 mm	9.8 mm / 9.5 mm	9.8 mm / 9.5 mm
Wire Size	1.6x1.4 mm	1.6x1.4 mm	1.6x1.4 mm	1.6x1.4 mm
Fastener Length	19 mm	25 mm	19 mm	25 mm
Air Consumption / 90ps	0.7 cfm	0.7 cfm	0.7 cfm	0.7 cfm
Cycle Rate	4~6 staples/second	4~6 staples/second	4~6 staples/second	4~6 staples/second
Loading Capacity	100 pcs	100 pcs	100 pcs	100 pcs
Working Pressure	70~120 psi	70~120 psi	70~120 psi	70~120 psi



## 5 IN 1 Aluminum Housing Staple Gun Tacker

Model No: 5 IN 1 SN



Model No	5 IN 1 SN
L x W x H	170x3x160 mm
Weight	545 gs

### APPLICATIONS

- Gypsum board
- Wood board
- Fastening papers

### FEATURES

- Patented 5 in 1 (drives both 140/53/13, T50/JT21 staples)
- No switch
- Aluminum Bi-material aluminum housing
- Steel inner magazine
- Comfortable dual-color handle
- Low staple refill window
- Safety Handle Lock system
- Bottom loading for easy loading & anti-jamming
- Stainless steel belt clip for easy to carry
- With 500pcs assort staples
- Big Volume capacity of magazine

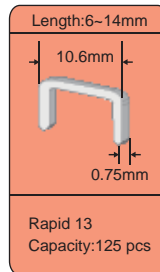
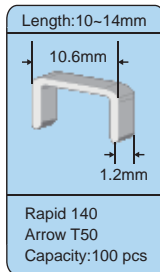
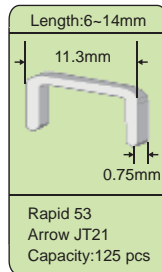
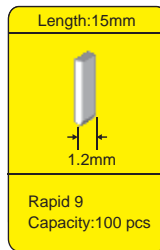
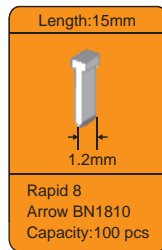

## 6 IN 1 Staple Gun Tacker

Model No: 6 IN 1 SN



Model No	6 IN 1 SN
L x W x H	170x3x160 mm
Weight	545 gs

### APPLICATIONS

- Gypsum board
- Wood board
- Fastening papers

### FEATURES

- Patented No - SWITCH
- 6 in 1 (drives both 140/T50/53/JT21/13 staples, Rapid 36 & Arrow T50 U staples)
- Bi-material aluminum housing
- Steel inner magazine
- Comfortable dual-color handle
- Low staple refill window
- Safety Handle Lock system
- Bottom loading for easy loading & anti-jamming
- Stainless steel belt clip for easy to carry
- With 500pcs assort staples
- Big Volume capacity of magazine Rapid 8, Arrow BN1810 brads, Rapid 9 pins

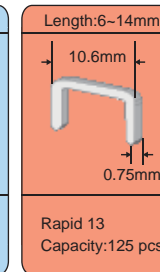
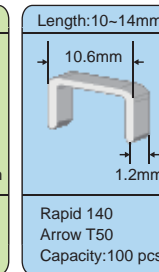
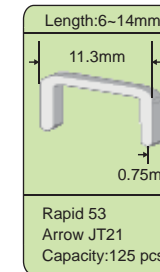
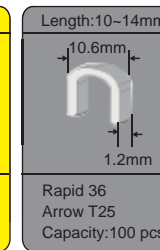
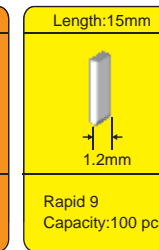
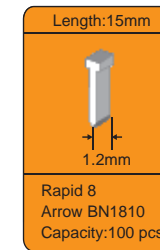

# 3 In 1 Tackers

Model No: S612T, S610T



Model No	S612T	S610T
L x W x H	160x28x132 mm	
Weight	215 gs	

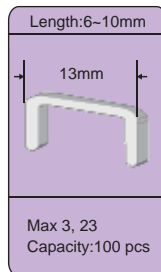
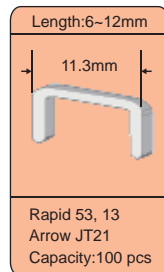

## APPLICATIONS :

### Staple Gun



Stapling function

### Organizer



Organizer function - Temporary fastening (staple stays above objective easy to be removed)

### Stapler



Paper stapler function - Fasten up to 50 sheets of A4 paper

## Suitable Staple



ST612T / 6-12 mm



S610T / 6-10 mm

## FEATURES

- Regular stapling
- Office heavy stapler
- Temporary fastening/staple stays above objective
- High impact plastic mold housing
- Bottom loading for easy loading & anti-jamming
- Big volume capacity of magazine



# 3 In 1 Tackers

Model No: T53S, T13S, T3S, T23S



Model No	T53S	T13S	T3S	T23S
L x W x H	156x25x115 mm	160x28x132 mm		
Weight	495 gs	215 gs		

<p>Length: 6-12mm 11.3mm</p> <p>Rapid 53, 13 Arrow JT21 Capacity: 100 pcs</p>	<p>Length: 6-12mm 11.3mm</p> <p>Rapid 13 Capacity: 100 pcs</p>	<p>Length: 6-12mm 13mm</p> <p>Max 3, T3, 12/23 series Capacity: 100 pcs</p>	<p>Length: 6-13mm 13mm</p> <p>Max 3, T3, 12/23 series Capacity: 100 pcs</p>
---	--	---	---

## APPLICATIONS :

### Staple Gun



Stapling function

### Organizer



Organizer function - Temporary fastening (staple stays above objective easy to be removed)

### Stapler



Paper stapler function - Fasten up to 50 sheets of A4 paper

## Suitable Staple



T53S / 6-12 mm



T13S / 6-12 mm



T3S / 6-12 mm



T23S / 6-13 mm

## FEATURES

- Staple gun function
- Handy paper stapler function (60 sheets)
- Temporary fastening/staple stays above objective
- Durable all metal construction
- Big volume capacity of magazine
- All Chrome plated
- Bottom loading for easy loading & anti-jamming



## Vertical Mini-Box Stitchers

Model No: VS7351, VS7352, VS8401, VS8402, VS11601, VS11602

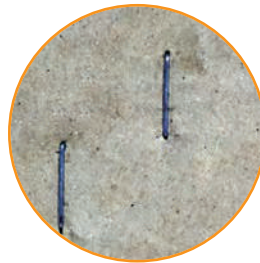
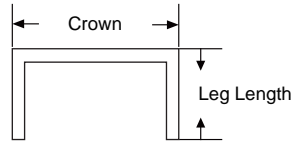

L x W x H	24x44x50 cm
Weight	40 kgs
Wire used	flat wire 0.45~0.5 x0.85~0.9 mm
Power Required	1/8 HP, single phase

Model No	Crown	Leg Length	Throat Depth	Capacity (per min)
VS7351	7 mm	3.5 mm	21 cm	270 pcs
VS7352	7 mm	3.5 mm	21 cm	220 pcs
VS8401	8 mm	4.0 mm	21 cm	270 pcs
VS8402	8 mm	4.0 mm	21 cm	220 pcs
VS11601	11 mm	6.0 mm	21 cm	270 pcs
VS11602	11 mm	6.0 mm	21 cm	220 pcs

### APPLICATION

- Cardboard box packaging
- Color box packaging
- Blister packs packaging

### FEATURES

- Easy operation - automatic stapling and foot pedal control
- Mini size - occupied only 24x44 cm
- Precision engineered parts - extend you a faultless job and perfect clinching
- Deep throat - up to 21 cm for a wide range of stapling

## Horizontal Mini-Box Stitchers

Model No: HS10451, HS10452

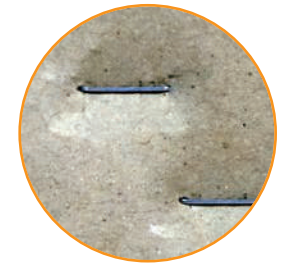
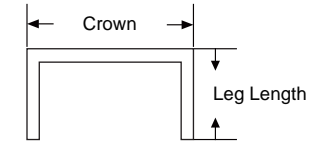

L x W x H	20x40x44 cm
Weight	25 kgs
Wire used	0.5 mm dia
Power Required	1/8 HP

Model No	Crown	Leg Length	Throat Depth	Capacity (per min)
HS10451	10 mm	4.5 mm	10 cm	300 pcs
HS10452	10 mm	4.5 mm	10 cm	250 pcs

### APPLICATION

- Cardboard box packaging

### FEATURES

- Easy operation - automatic stapling and foot pedal control
- Mini size - occupied only 20x40 cm
- Precision engineered parts - extend you a faultless job and perfect clinching
- Deep throat - up to 10 cm for a wide range of stapling



## 11 GA. Jumbo Manual Hog Ring Pliers

Model No: MHR50



Model No	MHR50
L x W x H	680x150x130 mm
Weight	4.2 kgs
Crown	45 mm
Shank Dia	3.0 mm
Closure Size	11~13 mm
Capacity	40 pcs
Equivalent	Stanley Bostitch Spenax ® SC50HP

### APPLICATION

- Gabion jobsites
- Erosion protection
- Retaining walls
- Soil reinforcement
- Road construction
- Coastal protection
- Civil engineering
- Silt fence
- Sand bag

### FEATURES

- Quick to use
- Easy loading of ring
- Ergonomic design
- Easy operated
- Jam-free system
- Durable
- Light weight



## 11 GA. Jumbo Pneumatic Gabion Hog Ring Pliers

Model No: JHR11130



Model No	JHR11130
L x W x H	510x240x370 mm
Weight	6.3 kgs
Capacity	120 pcs
Air Pressure	5~6 bar
Max Air Pressure	8 bar
Equivalent	Stanley Bostitch Spenax ® SC50HP MEIHO ® MC-50-1G

### APPLICATION

- Very large bag closure
- Gabion
- Coastal protection
- Civil engineering
- Erosion protection retaining walls soil reinforcement
- Road construction

### FEATURES

- Air driven





## 15 GA. Hog Ring Pliers With Extension Nose

Model No: HR1880L



Model No	HR1880L
L x W x H	355x90x205 mm
Weight	1.56 kgs
Crown	23.7 mm
Shank Dia	1.8 mm
Minimum Closure Size	8.0 mm
Capacity	100 pcs
Working Pressure	90~105 psi
Equivalent	Stanley Bostitch Spenax ® SC50HP, SC7C, SC7E MEIHO ® MC-6CA, MC-6CALW

### APPLICATION

- Pocket spring mattress assembly
- Car seating assembly
- Mattress upholstery (Bedding Industry)
- Bag closure
- Fences, greenhouses, cages assembly
- Industry in general

### FEATURES

- Long fiber compounds make it lighter and faster
- Reduce operator fatigue
- Easy loading process
- Muffler inside provides silent operation
- 60.5 mm extended nose for coiling deeper corner
- Extended magazine for loading 100 pcs of hog ring is available



Car Seat Industry



Sofa Industry

## 15 GA. Hog Ring Pliers

Model No: HR1845, HR1848, HR1850, HR1855, HR1865, HR1880



Model No	HR1845	HR1848	HR1850	HR1855	HR1865	HR1880
L x W x H	325x90x205 mm					
Weight	1.54 kgs					
Crown	23.7 mm					
Shank Dia	1.8 mm					
Shank Height	12 mm					
Minimum Closure Size	4.5 mm	4.8 mm	5.0 mm	5.5 mm	6.5 mm	8.0 mm
Capacity	100 pcs					
Working Pressure	90~105 psi					
Equivalent	Stanley Bostitch Spenax ® S4CLW, SC7C, SC7E MEIHO ® MC-6CA, MC-6CALW					

### APPLICATION

- Pocket spring mattress assembly
- Car seating assembly
- Mattress upholstery (Bedding Industry)
- Bag closure
- Fences, greenhouses, cages assembly
- Industry in general

### FEATURES

- Long fiber compounds make it lighter and faster
- Reduce operator fatigue
- Easy loading process
- Muffler inside provides silent operation
- Extended magazine for loading 100 pcs of hog ring is available



## 16 GA. Hog Ring Pliers

Model No: HR1616, HR1626, HR1630, HR1648



Model No	HR1616	HR1626	HR1630	HR1648
L x W x H	285x100x200 mm			
Weight	1.56 kgs			
Crown	16.9 mm			
Shank Dia	1.6 mm			
Minimum Closure Size	1.6 mm	2.6 mm	3.0 mm	4.8 mm
Capacity	100 pcs			
Working Pressure	90~105 psi			
Equivalent	HR1616: Stanley Bostitch Spenax ® SC73462 HR1630: Stanley Bostitch Spenax ® SC760 MEIHO ® MC-660 HR1648: Stanley Bostitch Spenax ® SC761			

### APPLICATION

- Pocket spring mattress assembly
- Car seating assembly
- Mattress upholstery (Bedding Industry)
- Bag closure
- Fences, greenhouses, cages assembly
- Industry in general
- Sofa spring assembly

### FEATURES

- Long fiber compounds make it lighter and faster
- Reduce operator fatigue
- Easy loading process
- Muffler inside provides silent operation
- Extended magazine for loading 100 pcs of hog ring is available



Mattress, spring industry

## 16 GA. Hog Ring Pliers

Model No: HR743, HR1665



Model No	HR743	HR1665
L x W x H	315x90x182 mm	
Weight	1.45 kgs	
Crown	23.7 mm	
Shank Dia	1.6 mm	
Shank Height	12 mm	
Minimum Closure Size	4.8 mm	6.5 mm
Capacity	100 pcs	
Working Pressure	90~105 psi	
Equivalent	HR743: Stanley Bostitch Spenax ® SC743	

### APPLICATION

- Pocket spring mattress assembly
- Car seating assembly
- Mattress upholstery (Bedding Industry)
- Bag closure
- Fences, greenhouses, cages assembly
- Industry in general
- Sofa spring assembly

### FEATURES

- Long fiber compounds make it lighter and faster
- Reduce operator fatigue
- Easy loading process
- Muffler inside provides silent operation
- Extended magazine for loading 100 pcs of hog ring is available



Mattress, spring industry



## Hog Ring Pliers

Model No: HR1635



Model No	HR1635
L x W x H	270x87x193 mm
Weight	1.59 kgs
Crown	17 mm
Shank Dia	1.6 mm
Closure Size	2.8~3.5 mm
Capacity	130 pcs
Working Pressure	80~100 psi
Equivalent	Stanley Bostitch Spenax® SC760 MEIHO® MC-660

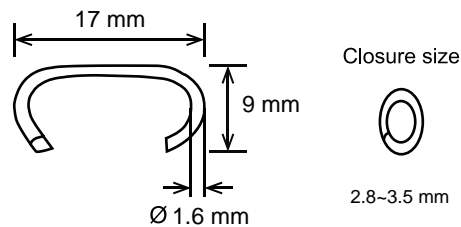

## Hog Ring Pliers

Model No: HR1648T



Model No	HR1648T
L x W x H	270x87x193 mm
Weight	1.59 kgs
Crown	17 mm
Shank Dia	1.6 mm
Closure Size	4.8~5.6 mm
Capacity	130 pcs
Working Pressure	80~100 psi
Equivalent	Stanley Bostitch Spenax® SC761

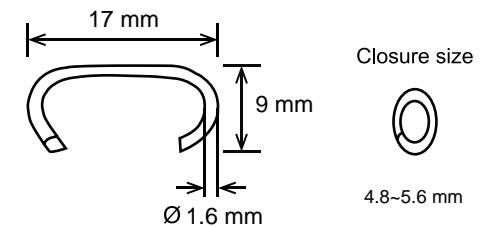

### APPLICATION

- Mattress, car seat, building construction
- Fencing connection, installation
- Poultry cage, traps and cables

### FEATURES

- Balanced, lightweight, ergonomically designed
- Easy-to-load anti back-up magazine
- Can be easily converted to right or left hand operation

### APPLICATION

- Mattress, car seat, building construction
- Fencing connection, installation
- Poultry cage, traps and cables

### FEATURES

- Balanced, lightweight, ergonomically designed
- Easy-to-load anti back-up magazine
- Can be easily converted to right or left hand operation



## 16 GA. Hog Ring Pliers

Model No: HR1687T



Model No	HR1687T
L x W x H	335X102X193 mm
Weight	1.52 kgs
Crown	24 mm
Shank Dia	1.6 mm
Closure Size	4.8-8.7 mm
Capacity	120 pcs
Working Pressure	80-110 psi

### APPLICATION

- Mattress, car seat, building construction
- Fencing connection, installation
- Poultry cage, traps and cables

### FEATURES

- Balanced, lightweight, ergonomically designed
- Extend jaw enable to attach the thicker material
- Easy-to-load anti back-up magazine
- Can be easily converted to right or left hand operation

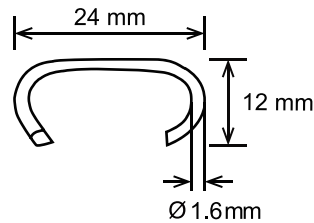

Closure size



4.8-8.7mm

## 14.5 & 16 GA. Outward Hog Ring Pliers

Model No: HR16107S, HR16107M, HR16107L, HR1687, HR14556, HR1656, HR15256



Model No	HR16107S	HR16107M	HR16107L	HR1687	HR14556	HR1656	HR15256
L x W x H (mm)	336x220x89	351x220x89	359x220x89	336x220x89	336x220x89	336x220x89	336x220x89
Weight (kgs)	1.4	1.45	1.5	1.4	1.4	1.4	1.4
Gauge	16 GA	16 GA	16 GA	14.5 GA	16 GA	16 GA	16 GA
Crown (A)	23.47 mm	23.47 mm	23.47 mm	23.47 mm	16.48 mm	23.47 mm	16.4 mm
Dia (B)	1.6 mm	1.6 mm	1.6 mm	1.6 mm	1.45 mm	1.6 mm	1.52 mm
Closure Size (C)	7.9-10.7 mm	7.9-10.7 mm	7.9-10.7 mm	4.8-8.7 mm	2.8-5.6 mm	2.8-5.6 mm	2.8-5.6 mm
Jaw Length	25 mm	40 mm	48 mm	25 mm	25 mm	25 mm	25 mm
Magazine Capacity	110 pcs						
Working Pressure	90-105 psi						
Equivalent	HR16107S: Stanley Bostitch Spenax © SC743SG HR1687: Stanley Bostitch Spenax © SC743 HR1656: Stanley Bostitch Spenax © SC760 / MEIHO © MC-660						

### APPLICATION

- Small, medium, large bag closure
- Mesh bag closure
- Cage grid secured
- Attaching the label
- Auto seat
- Spring ben

### FEATURES

- Long fiber compounds make it lighter and faster
- Reduce operator fatigue
- Easy loading process
- Muffler inside provides silent operation



## Hog Ring Pliers

Model No: HR1887T



Model No	HR1887T
L x W x H	335X102X193 mm
Weight	1.52 kgs
Crown	24 mm
Shank Dia	1.8 mm
Closure Size	4.8-8.7 mm
Capacity	120 pcs
Working Pressure	80-110 psi
Equivalent	Stanley Bostitch Spenax® S4CLW, SC7C, SC7E MEIHO® MC-6LNA, MC-6LNALW, MC-6CA, MC-6CALW

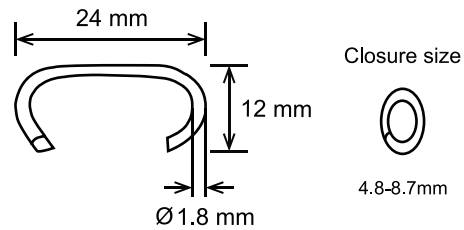

### APPLICATION

- Bedding, spring mattress, car seat, building construction
- Fencing connection, installation
- Poultry cage, traps and cables

### FEATURES

- Balanced, lightweight, ergonomically designed
- Easy-to-load anti back-up magazine
- Can be easily converted to right or left hand operation

## Hog Ring Pliers

Model No: HR18107



Model No	HR18107
L x W x H	335x102x193 mm
Weight	1.52 kgs
Crown	24 mm
Shank Dia	1.8 mm
Closure Size	7.9-10.7 mm
Capacity	120 pcs
Working Pressure	80-110 psi
Equivalent	Stanley Bostitch Spenax® S4CLW, SC7C, SC7E MEIHO® MC-6LNA, MC-6LNALW, MC-6CA, MC-6CALW

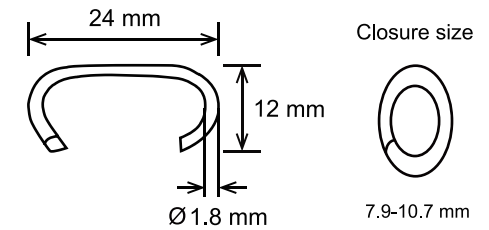

### APPLICATION

- Mattress, car seat, building construction
- Fencing connection, installation
- Poultry cage, traps and cables

### FEATURES

- Balanced, lightweight, ergonomically designed
- Extend jaw enable to attach the thicker material
- Easy-to-load anti back-up magazine
- Can be easily converted to right or left hand operation



## 15 GA. Inward Hog Ring Pliers

Model No: HR18107S, HR18107M, HR18107L, HR1887



Model No	HR18107S	HR18107M	HR18107L	HR1887
L x W x H (mm)	336x220x89	351x220x89	359x220x89	336x220x89
Weight (kgs)	1.4	1.45	1.5	1.4
Crown (A)	23.87 mm	23.87 mm	23.87 mm	23.87 mm
Dia (B)	1.8 mm	1.8 mm	1.8 mm	1.8 mm
Closure Size (C)	7.9~10.7 mm	7.9~10.7 mm	7.9~10.7 mm	4.8~8.7 mm
Jaw Length	25 mm	40 mm	48 mm	25 mm
Magazın Capacity	100 pcs			
Working Pressure	90~105 psi			
Equivalent	HR18107S: Stanley Bostitch Spenax® SC7 / MEIHO® MC-6, MC-6LW HR18107M: Stanley Bostitch Spenax® SC7E / MEIHO® MC-6LNA, MC-6LNALW HR18107L: Stanley Bostitch Spenax® SC77XE HR1887: Stanley Bostitch Spenax® SC7C / MEIHO® MC-6CA, MC-6CALW			

### APPLICATION

- Small, medium, large bag closure
- Mesh bag closure
- Cage grid secured
- Attaching the label
- Auto seat
- Spring ben

### FEATURES

- Long fiber compounds make it lighter and faster
- Reduce operator fatigue
- Easy loading process
- Muffler inside provides silent operation

## 15 GA. Hog Ring Pliers

Model No: HR18107LN



Model No	HR18107LN
L x W x H	193x102x355 mm
Weight	1.29 kgs
Crown	24 mm
Shank Dia	1.8 mm
Closure Size	7.9~10.7 mm
Capacity	120 pcs
Working Pressure	80~110 psi
Equivalent	Stanley Bostitch Spenax® SC7E MEIHO® MC-6LNA, MC-6LNALW

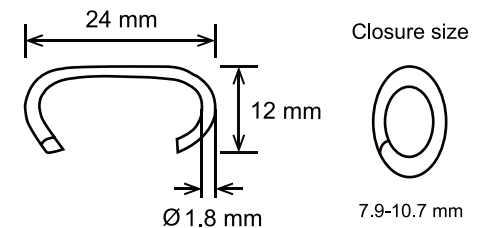

### APPLICATION

- Mattress, car seat, building construction
- Fencing connection, installation
- Poultry cage, traps and cables

### FEATURES

- Balanced, lightweight, ergonomically designed
- Extend jaw enable to attach the thicker material
- Easy-to-load anti back-up magazın
- Can be easily converted to right or left hand operation



# 15 GA. Hog Ring Pliers

Model No: HR18107XLN



Model No	HR18107XLN
L x W x H	193x102x380 mm
Weight	1.6 kgs
Crown	24 mm
Shank Dia	1.8 mm
Closure Size	7.9-10.7 mm
Capacity	120 pcs
Working Pressure	80-110 psi
Equivalent	Stanley Bostitch Spenax® SC7XXE

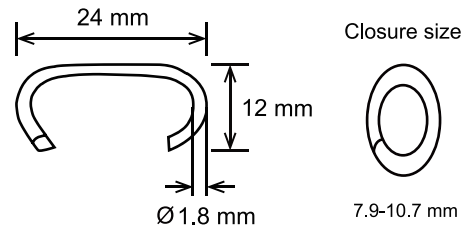

## APPLICATION

- Mattress, car seat, building construction
- Fencing connection, installation
- Poultry cage, traps and cables

## FEATURES

- Balanced, lightweight, ergonomically designed
- Extend jaw enable to attach the thicker material
- Easy-to-load anti back-up magazine
- Can be easily converted to right or left hand operation



## Battery Hog Ring Pliers

Model No: HR107B, HR87B



Model No	HR107B	HR87B
L x W x H	373x115x255 mm	
Weight	2.56 kgs	
Crown	24 mm	
Shank Dia	1.8 mm	
Closure Size	7.9-10.7 mm	4.8-8.7 mm
Capacity	120 pcs	
Battery Pack	Li-ion 14.4V-4.0Ah	
Charging Time	60 mins	
Charging Input	AC 100-240V / 50-60 Hz	
Charging Output	DC 10.8-14.4 V	

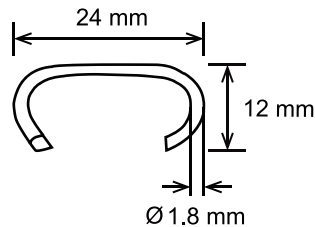

Closure size



7.9-10.7 mm  
HR107B



4.8-8.7 mm  
HR87B

### APPLICATION

- Mattress, car seat, building construction
- Fencing connection, installation
- Poultry cage, traps and cables, wire to wire applications

### FEATURES

- 1600-1800 shots per battery charge
- Powerful and speed
- Big range of closure
- Powerful saving mode
- Digital control

## Battery Hog Ring Pliers

Model No: HR56B



Model No	HR56B
L x W x H	373x115x255 mm
Weight	2.56 kgs
Crown	17 mm
Shank Dia	1.6 mm
Closure Size	2.5-5.6 mm
Capacity	130 pcs
Battery Pack	Li-ion 14.4V-4.0Ah
Charging Time	60 mins
Charging Input	AC 100-240V / 50-60 Hz
Charging Output	DC 10.8-14.4 V

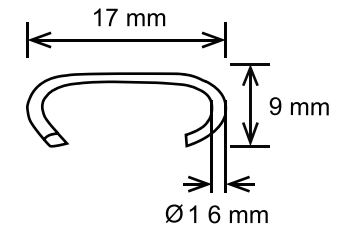

Closure size



2.5-5.6mm

### APPLICATION

- Mattress, car seat, building construction
- Fencing connection, installation
- Poultry cage, traps and cables, wire to wire applications

### FEATURES

- 1600-1800 shots per battery charge
- Powerful and speed
- Big range of closure
- Powerful saving mode
- Digital control





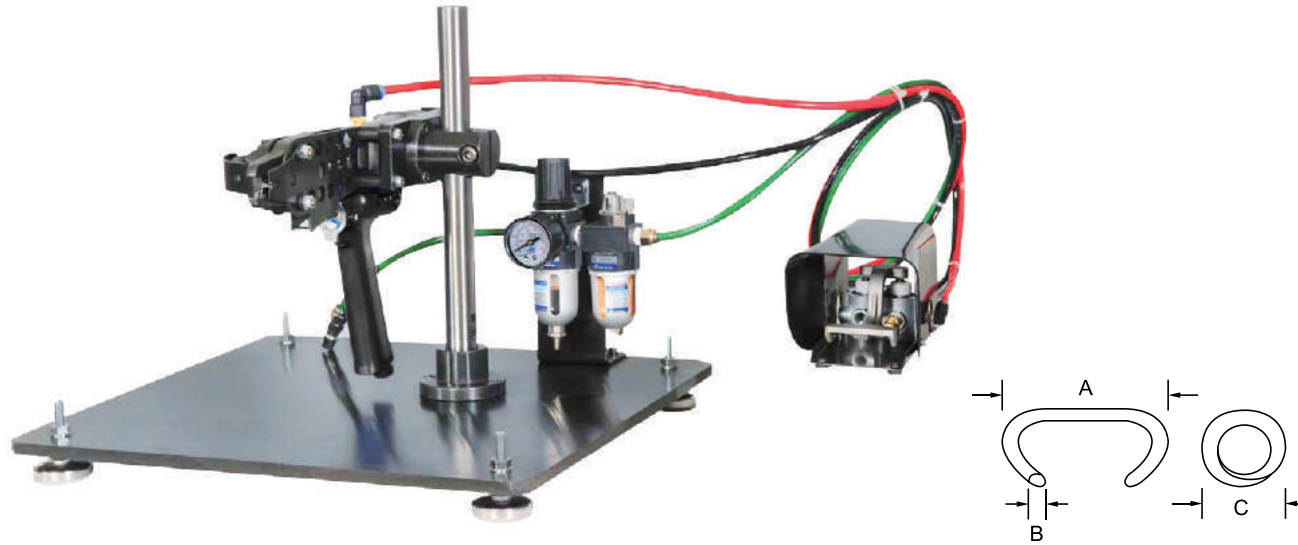

## Pneumatic Hog Ring Pliers With Pedal

Model No: HRP18107SO, HRP18107MO, HRP1887LO, HRP1887S, HRP16107S, HRP16107M, HRP1687L, HRP1687S, HRP1656, HRP18107SI, HRP18107MI, HRP18107LI



Model No	HRP18107SO	HRP18107MO	HRP1887LO	HRP1887S	HRP16107S	HRP16107M	HRP1687L	HRP1687S	HRP1656	HRP18107SI	HRP18107MI	HRP18107LI
L x W x H (mm)	400x400x335	400x400x335	400x400x335	400x400x335	400x400x335	400x400x335	400x400x335	400x400x335	400x400x335	400x400x335	400x400x335	400x400x335
Weight (kgs)	19.4	19.4	19.4	19.4	19.4	19.4	19.4	19.4	19.4	19.4	19.4	19.4
Nose Size	25 mm	40 mm	48 mm	25 mm	25 mm	40 mm	48 mm	25 mm	25 mm	25 mm	40 mm	48 mm
Crown (A)	23.9 mm	23.9 mm	23.9 mm	23.9 mm	23.47 mm	23.47 mm	23.47 mm	23.47 mm	16.9 mm	23.9 mm	23.9 mm	23.9 mm
Dia (B)	1.8 mm	1.8 mm	1.8 mm	1.8 mm	1.6 mm	1.6 mm	1.6 mm	1.6 mm	1.6 mm	1.8 mm	1.8 mm	1.8 mm
Closure Size (C)	7.9~10.7 mm	7.9~10.7 mm	4.8~8.7mm	4.8~8.7 mm	7.9~10.7 mm	7.9~10.7 mm	4.8~8.7mm	4.8~8.7 mm	2.8~5.6 mm	7.9~10.7 mm	7.9~10.7 mm	7.9~10.7 mm
Loading Capacity	100 pcs	100 pcs	100 pcs	100 pcs	100 pcs	100 pcs	100 pcs	100 pcs	100 pcs	100 pcs	100 pcs	100 pcs
Working Pressure	70~90 psi	70~90 psi	70~90 psi	70~90 psi	70~90 psi	70~90 psi	70~90 psi	70~90 psi	70~90 psi	70~90 psi	70~90 psi	70~90 psi
Closure Type	C-ring forming with edge outward 									C-ring forming with inward edge 		



## 15 GA. Rope Hog Ring Pliers

Model No: C22R / C26R



Model No	C22R	C26R
L x W x H	170x40x15 mm	
Weight	0.25 kgs	
Gauge	15 GA	
Crown	21.7 mm	25.5 mm
Height	11.5 mm	13 mm
Closure Size	12 mm	13 mm

### APPLICATION

- Hog ring
- Automotive upholstery
- Domestic upholstery
- Lobster and crab taps
- Wire cages
- Fence joining
- Gardening
- Floral arrangements
- Netting
- Insulation blankets
- Rope
- Cord
- Fabric
- Ranch
- Agriculture

### FEATURES

- Easy one hand operation
- Cushion grip handle keeps hands comfortable
- Spring-loaded design for smooth operation
- Machined and hardened forged steel for increased durability
- Specially designed to hold hog rings securely in place
- Made with opening spring to help keep tension while using with 3/4" hog ring clips

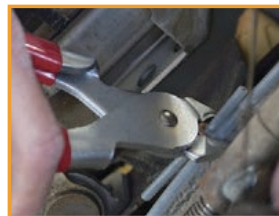
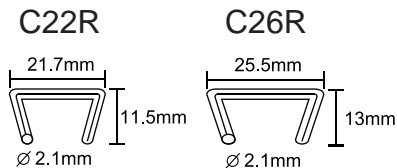

## 15 GA. Fabric Hog Ring Pliers

Model No: C22A / C26A



Model No	C22A	C26A
L x W x H	190x30x15 mm	
Weight	0.25 kgs	
Gauge	15 GA	
Crown	21.7 mm	25.5 mm
Height	11.5 mm	13 mm
Closure Size	12 mm	13 mm

### APPLICATION

- Hog ring
- Automotive upholstery
- Domestic upholstery
- Lobster and crab taps
- Wire cages
- Fence joining
- Gardening
- Floral arrangements
- Netting
- Insulation blankets
- Rope
- Cord
- Fabric
- Ranch
- Agriculture

### FEATURES

- Spring loaded jaws hold the hog rings during use
- Easy one hand operation
- Steel pliers are durable
- Made with opening spring to help keep tension while using with 3/4" hog ring clips
- Cushion grip handle keeps hands comfortable
- Angled nose hog ring pliers have a 45 degree angled
- Head to fit into tight spaces and difficult spots

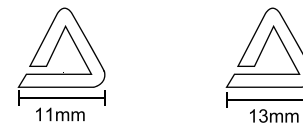
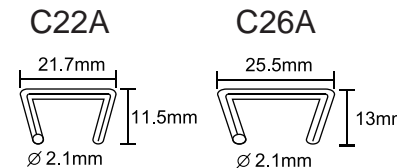

## Pneumatic Stapling Pliers

Model No: SP103020DR,SP5019DR,SPSFDR,SP777DR,SP779DR

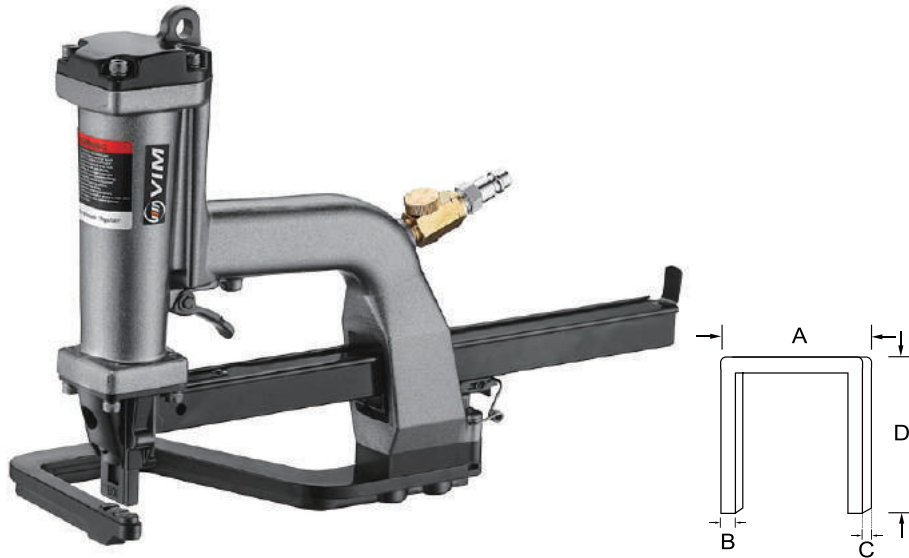

L x W x H	370x55x240 mm
Weight	2.2 kgs
Air Pressure	36~55 psi



Model No	Crown(A)	Width(B)xThickness(C)	Staples Length(D)	Magazine Capacity
SP103020DR	12.95 mm	2.6 x 0.6 mm	9.5, 12.7, 15.8 mm	110 pcs
SP5019DR	12.85 mm	1.27 x 0.55 mm	6.3, 9.5, 12.7, 15.8 mm	220 pcs
SPSFDR	13.3 mm	1.0 x 0.72 mm	10, 13, 15 mm	280 pcs
SP777DR	12.3 mm	0.65 x 2.25 mm	9.5, 12.7, 15.8 mm	140 pcs
SP779DR	12.3 mm	0.63 x 1.3 mm	8, 9.5, 12.7, 14, 15.8 mm	250 pcs

### APPLICATION

- Fastening corrugated containers
- Vegetable tray boxes
- End caps
- Pallet boxes

### FEATURES

- Powerful shuttle blade provides pre-compression prior and during the stapling operation giving a strong, tight closure without breaking the corrugated surface
- High throat allows flexibility of staple placement and limits interference from obstacles such as box flanges
- C-Curved blade available for sealing partial overlap cartons
- Penetrates and securely fastens up to 2x AB flute or 4x C flute boards

## Pneumatic Stapling Pliers

Model No: SP103020A,SP5019A,SPSFA,SP777A,SP779A



L x W x H	370x55x240 mm
Weight	2.2 kgs
Air Pressure	36~55 psi



Model No	Crown(A)	Width(B)xThickness(C)	Staples Length(D)	Magazine Capacity
SP103020A	12.95 mm	2.6 x 0.6 mm	9.5, 12.7, 15.8 mm	110 pcs
SP5019A	12.85 mm	1.27 x 0.55 mm	6.3, 9.5, 12.7, 15.8 mm	220 pcs
SPSFA	13.3 mm	1.0 x 0.72 mm	10, 13, 15 mm	280 pcs
SP777A	12.3 mm	0.65 x 2.25 mm	9.5, 12.7, 15.8 mm	140 pcs
SP779A	12.3 mm	0.63 x 1.3 mm	8, 9.5, 12.7, 14, 15.8 mm	250 pcs

### APPLICATION

- Fastening corrugated containers
- Vegetable tray boxes
- End caps
- Pallet boxes
- Container inserts
- Die cut inserts
- Stapling of fabric

### FEATURES

- Powerful shuttle blade provides pre-compression prior and during the stapling operation giving a strong, tight closure without breaking the corrugated surface
- High throat allows flexibility of staple placement and limits interference from obstacles such as box flanges
- C-Curved blade available for sealing partial overlap cartons
- Penetrates and securely fastens up to 2x AB flute or 4x C flute boards



## Pneumatic Stapling Pliers

Model No: SP103020B,SP5019B,SPSFB,SP777B,SP779B

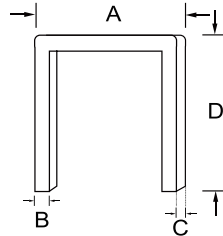
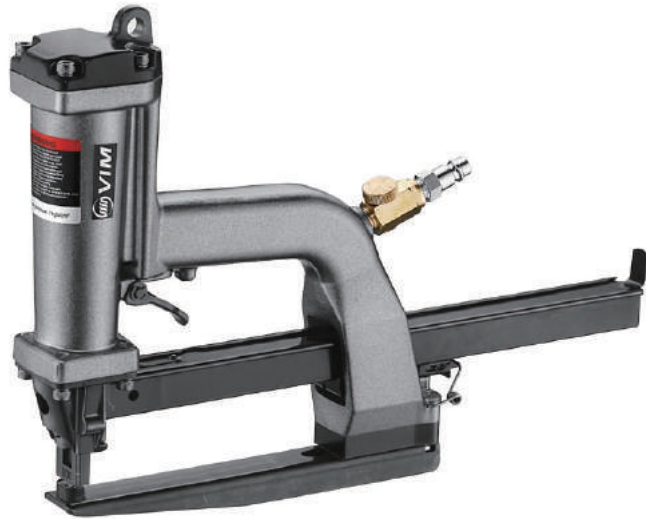

L x W x H	370x55x240 mm
Weight	2.2 kgs
Air Pressure	36~55 psi

Model No	Crown(A)	Width(B)xThickness(C)	Staples Length(D)	Magazine Capacity
SP103020B	12.95 mm	2.6 x 0.6 mm	9.5, 12.7, 15.8 mm	110 pcs
SP5019B	12.85 mm	1.27 x 0.55 mm	6.3, 9.5, 12.7, 15.8 mm	220 pcs
SPSFB	13.3 mm	1.0 x 0.72 mm	10, 13, 15 mm	280 pcs
SP777B	12.3 mm	0.65 x 2.25 mm	9.5, 12.7, 15.8 mm	140 pcs
SP779B	12.3 mm	0.63 x 1.3 mm	8, 9.5, 12.7, 14, 15.8 mm	250 pcs

### APPLICATION

- Fastening corrugated containers
- Vegetable tray boxes
- End caps
- Pallet boxes
- Container inserts
- Die cut inserts
- Stapling of fabric

### FEATURES

- Powerful shuttle blade provides pre-compression prior and during the stapling operation giving a strong, tight closure without breaking the corrugated surface
- High throat allows flexibility of staple placement and limits interference from obstacles such as box flanges
- C-Curved blade available for sealing partial overlap cartons
- Penetrates and securely fastens up to 2x AB flute or 4x C flute boards

## Pneumatic Stapling Pliers

Model No: SP103020CL,SP5019CL,SPSFCL,SP777CL,SP779CL

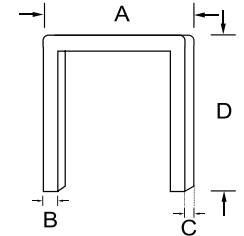
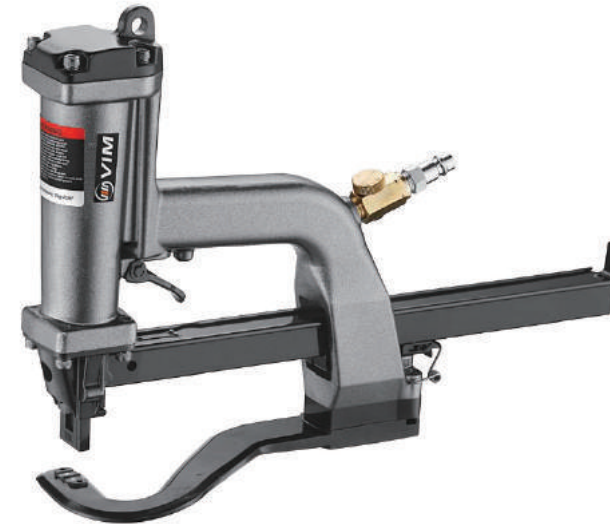

L x W x H	370x55x240 mm
Weight	2.2 kgs
Air Pressure	36~55 psi

Model No	Crown(A)	Width(B)xThickness(C)	Staples Length(D)	Magazine Capacity
SP103020CL	12.95 mm	2.6 x 0.6 mm	9.5, 12.7, 15.8 mm	110 pcs
SP5019CL	12.85 mm	1.27 x 0.55 mm	6.3, 9.5, 12.7, 15.8 mm	220 pcs
SPSFCL	13.3 mm	1.0 x 0.72 mm	10, 13, 15 mm	280 pcs
SP777CL	12.3 mm	0.65 x 2.25 mm	9.5, 12.7, 15.8 mm	140 pcs
SP779CL	12.3 mm	0.63 x 1.3 mm	8, 9.5, 12.7, 14, 15.8 mm	250 pcs

### APPLICATION

- Fastening corrugated containers
- Vegetable tray boxes
- End caps
- Pallet boxes

### FEATURES

- Powerful shuttle blade provides pre-compression prior and during the stapling operation giving a strong, tight closure without breaking the corrugated surface
- High throat allows flexibility of staple placement and limits interference from obstacles such as box flanges
- C-Curved blade available for sealing partial overlap cartons
- Penetrates and securely fastens up to 2x AB flute or 4x C flute boards



## Pneumatic Stapling Pliers

Model No: SP103020CR,SP5019CR,SPSFDCR,SP777CR,SP779CR

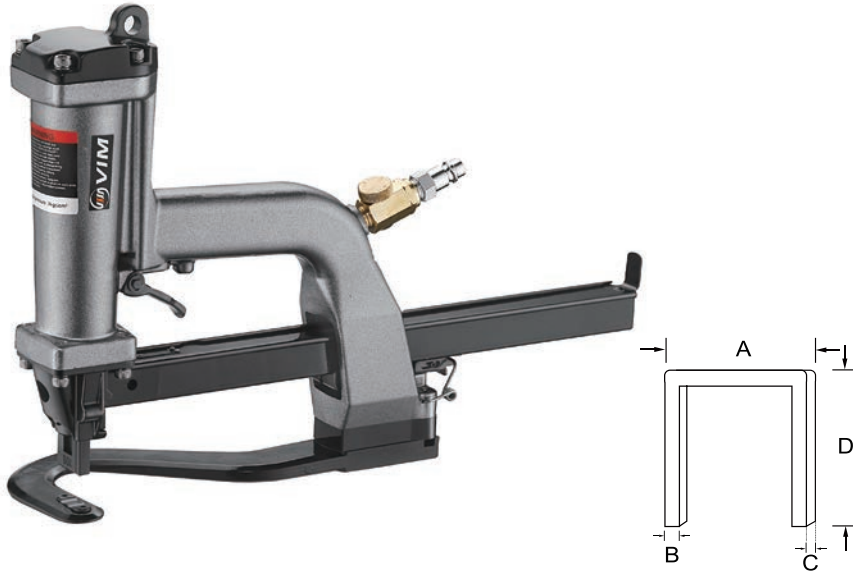

L x W x H	370x55x240 mm
Weight	2.2 kgs
Air Pressure	36~55 psi



Model No	Crown(A)	Width(B)xThickness(C)	Staples Length(D)	Magazine Capacity
SP103020CR	12.95 mm	2.6 x 0.6 mm	9.5, 12.7, 15.8 mm	110 pcs
SP5019CR	12.85 mm	1.27 x 0.55 mm	6.3, 9.5, 12.7, 15.8 mm	220 pcs
SPSFDCR	13.3 mm	1.0 x 0.72 mm	10, 13, 15 mm	280 pcs
SP777CR	12.3 mm	0.65 x 2.25 mm	9.5, 12.7, 15.8 mm	140 pcs
SP779CR	12.3 mm	0.63 x 1.3 mm	8, 9.5, 12.7, 14, 15.8 mm	250 pcs

### APPLICATION

- Fastening corrugated containers
- Vegetable tray boxes
- End caps
- Pallet boxes

### FEATURES

- Powerful shuttle blade provides pre-compression prior and during the stapling operation giving a strong, tight closure without breaking the corrugated surface
- High throat allows flexibility of staple placement and limits interference from obstacles such as box flanges
- C-Curved blade available for sealing partial overlap cartons
- Penetrates and securely fastens up to 2x AB flute or 4x C flute boards

## Pneumatic Stapling Pliers

Model No: SP103020DL,SP5019DL,SPSFDL,SP777DL,SP779DL

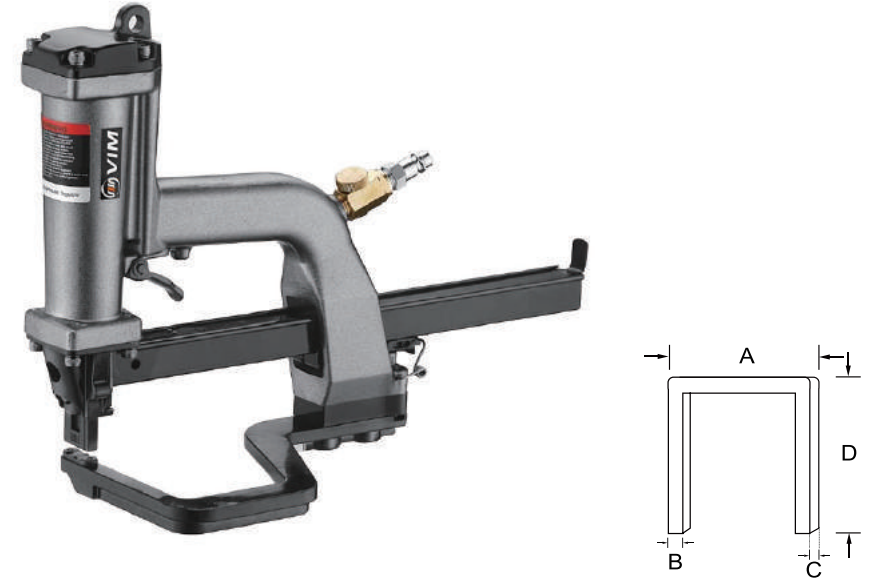

L x W x H	370x55x240 mm
Weight	2.2 kgs
Air Pressure	36~55 psi



Model No	Crown(A)	Width(B)xThickness(C)	Staples Length(D)	Magazine Capacity
SP103020DL	12.95 mm	2.6 x 0.6 mm	9.5, 12.7, 15.8 mm	110 pcs
SP5019DL	12.85 mm	1.27 x 0.55 mm	6.3, 9.5, 12.7, 15.8 mm	220 pcs
SPSFDL	13.3 mm	1.0 x 0.72 mm	10, 13, 15 mm	280 pcs
SP777DL	12.3 mm	0.65 x 2.25 mm	9.5, 12.7, 15.8 mm	140 pcs
SP779DL	12.3 mm	0.63 x 1.3 mm	8, 9.5, 12.7, 14, 15.8 mm	250 pcs

### APPLICATION

- Fastening corrugated containers
- Vegetable tray boxes
- End caps
- Pallet boxes

### FEATURES

- Powerful shuttle blade provides pre-compression prior and during the stapling operation giving a strong, tight closure without breaking the corrugated surface
- High throat allows flexibility of staple placement and limits interference from obstacles such as box flanges
- C-Curved blade available for sealing partial overlap cartons
- Penetrates and securely fastens up to 2x AB flute or 4x C flute boards



## Heavy-Duty Stapling Pliers

Model No: HP73



Model No	HP73
L x W x H	190x24x100 mm
Weight	460 gs
Fastener Range	6, 8, 10, 12 mm
Wire Size	1.25x0.5 mm
Equivalent	Rapid 31

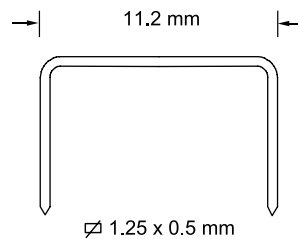

### APPLICATION

- Excellent for sealing small boxes and papers

### FEATURES

- All steel construction
- Three different type anvil

#### A Type Anvil



#### F Type Anvil



## 2 In 1 Stapling Pliers

Model No: P24



Model No	P24
L x W x H	180x26x86 mm
Weight	360 gs
Fastener Range	6.8 mm
Wire Size	24 series: 0.7x0.4 mm 26 series: 0.5x0.4 mm
Equivalent	Rapid 31

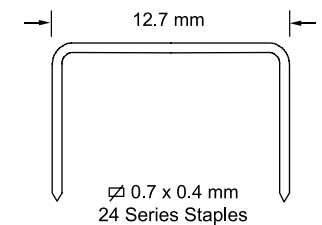

### APPLICATION

- Excellent for sealing small boxes and papers

### FEATURES

- All steel construction
- Three different type anvil

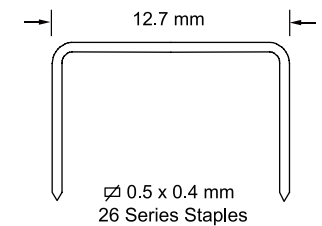

## Wide Crown Stapling Pliers

Model No: WCS2432

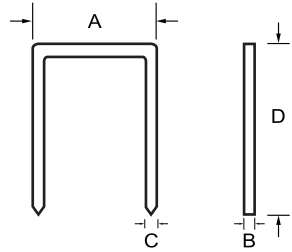

Model No	WCS2432
L x W x H	340x67x224 mm
Weight	2.5 kgs
Crown (A)	24 mm
Width(B)xThickness(C)	1.9 x 0.9 mm
Length(D)	16, 19, 22, 25, 28, 32 mm
Working Pressure	6~7 bar
Magazine Capacity	100 staples

### APPLICATION

- Suitable for closing large board packages, corrugated furniture wrap, stapling heavier cardboard, edge protection, closing end, etc.

### FEATURES

- It can fasten up to two layers of triple wall corrugated board
- The wide crown staples offer wide solutions in many heavy-duty packaging problems, such as fixing end caps to heavy fiber transport tubes and drums or connecting edge protectors
- The WCS2432 stapling pliers has a fixed tongue, which means that it can be rapidly moved sideways

## Tacker With Walking Stick

Model No: PT2432

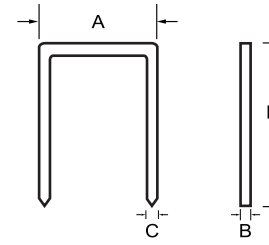

Model No	PT2432
L x W x H	340x67x224 mm
Weight	2.5 kgs
Crown (A)	24 mm
Width(B)xThickness(C)	1.9 x 0.9 mm
Length(D)	16, 19, 22, 25, 28, 32 mm
Working Pressure	6~7 bar
Magazine Capacity	100 staples

### APPLICATION

- Ideal for fixing carton to pallet

### FEATURES

- Single fire
- Contact safety device
- Top loading
- Walking stick extension
- Rubber grip



## D-Ring Pliers

Model No: DP22DR

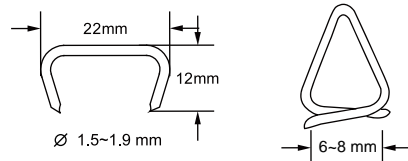

Model No	DP22DR
L x W x H	243x87x258 mm
Weight	1.35 kgs
Crown	22 mm
Shank Dia	1.5~1.9 mm
Shank Height	12 mm
Closure Size	6~8 mm
Capacity	60 pcs
Operation Pressure	80~110 psi

### APPLICATION

- Spring mattress
- Bag closure
- Poultry cage
- Bedding
- Fencing
- Building construction
- Furniture
- Ticking (flange) to innerspring
- Novelty
- Components

### FEATURES

- Balanced, lightweight, ergonomically designed
- Easy-to-load magazine
- 360° rotation magazine

## D-Ring Pliers

Model No: DP22DRL

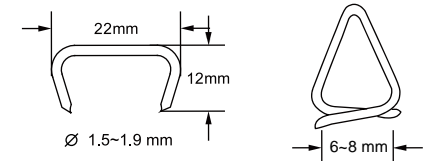

Model No	DP22DRL
L x W x H	338x87x258 mm
Weight	1.43 kgs
Crown	22 mm
Shank Dia	1.5~1.9 mm
Shank Height	12 mm
Closure Size	6~8 mm
Capacity	120 pcs
Operation Pressure	80~110 psi

### APPLICATION

- Spring mattress
- Bag closure
- Poultry cage
- Bedding
- Fencing
- Building construction
- Furniture
- Ticking (flange) to innerspring
- Novelty
- Components

### FEATURES

- Balanced, lightweight, ergonomically designed
- Easy-to-load magazine
- 360° rotation magazine





## Bedding Pliers

Model No: P88



Model No	P88
L x W x H	330x70x350 mm
Weight	2.1 kgs
Crown (A)	13.1 mm
Width (B) x Thickness (C)	1.2x0.5 mm
Length (D)	12~25 mm
Capacity	200 pcs

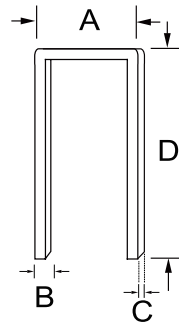

### APPLICATION

- Furniture, bedding
- Ticking(Flange) to innerspring
- Novelty
- Components

### FEATURES

- Easy loading



The world's lightest  
and  
the most compact  
clinchng pliers

# Plastic Clinching Pliers

Model No: VM45, VM46, VM65, VM66, VM85

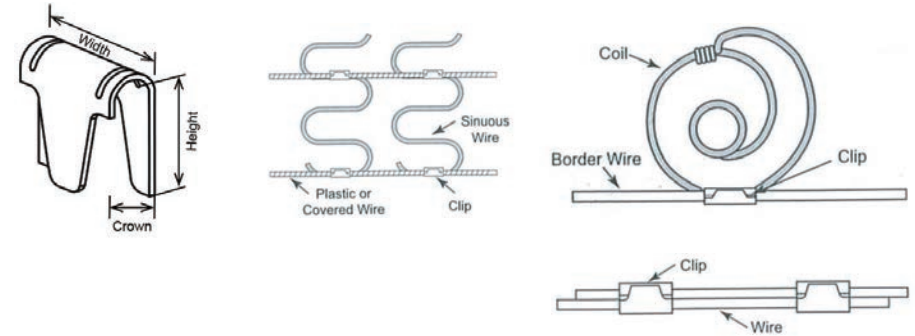

## APPLICATION

- Beds, easy chair, gates, windows and protection frames

## FEATURES

- Well balance, fast and top quality
- Light weight, 40% lighter than competitive models
- Composite plastic housing and magazine, quieter
- Simplest blade, anvil and pusher spring design
- Fewer parts, reliable and lower maintenance

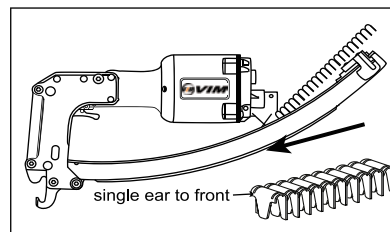
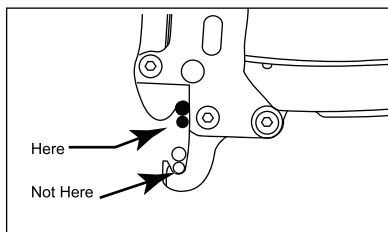
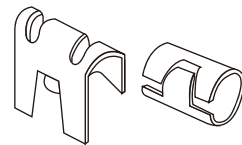
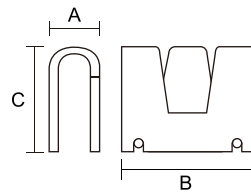

Model No	VM45	VM46	VM65	VM66	VM85
L x W x H	413x94x195 mm				
Weight	2.04 kgs				
Crown (A)	6.4 mm	7.9 mm	6.4 mm	7.9 mm	8.5 mm
Width (B)	11 mm	11 mm	19~22 mm	19~22 mm	22 mm
Height (C)	10.7~12.7 mm	13.3 mm	12.7~15.5 mm	12.7~15.5 mm	17.1 mm
Load Capacity	40 pcs				
Pressure	80~90 psi				

Model No	Crown	Height	22	19	11
VM45	6.4 mm	10.7 mm 12.7 mm			CL-13 CL-17
VM46	7.9 mm	13.3 mm			CL-18
VM65	6.4 mm	12.7 mm 15.5 mm	CL-23 CL-24	CL-73 CL-74	
VM66	7.9 mm	12.3 mm 14.1 mm 15.5 mm	CL-03 CL-04	CL-71 CL-72	
VM85	8.5 mm	17.1 mm	CL-34		



## Auto Feed Omega Pliers

Model No: M20S



Model No	M20S
L x W x H	190x130x170 mm
Weight	0.36 kgs
Wire Dia	2.0 mm
Crown	20 mm
Height	11 mm
Capacity	50 pcs

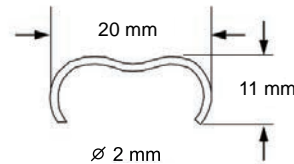

Closure Size

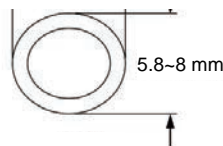

### APPLICATION

- Wire netting
- Chain link fencing
- Bagging
- Poultry caging
- Rope tying
- Insulation

### FEATURES

- Light and handy tool with easy fit magazine
- 50 hog ring magazine load capacity
- Professional - robust construction
- Anti-rust coating
- The perfect tool to fix young plants, secure growing branches and attach a net
- Automatically feeds the rings into the jaws
- The magazine pivots to allow tool to reach into difficult areas

## 16 GA. Manual Auto Feed C Ring Pliers

Model No: C8



Model No	C8
L x W x H	185x100x22 mm
Weight	0.34 kgs
Gauge	16 GA
Shank Dia	1.20x1.75 mm
Crown	19.5 mm
Closure Size	7-9 mm
Capacity	50 pcs

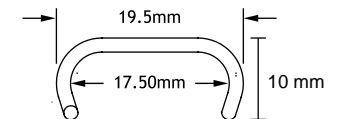

Closure Size

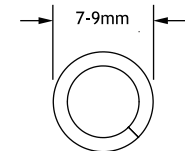

### APPLICATION

- Closing mesh poultry bag.
- Fencing
- Nursery
- Cage frame
- Netting
- Gabion basket installations
- Small bag closure

### FEATURES

- Automatic feed
- One hand operation
- Black coated finish
- Anti slip red handles
- Chrome plated magazine
- Durable all steel construction
- Magazine capacity 50 pcs



# Stapling Pliers

Model No: SP3



Model No	SP3
L x W x H	185x20x85 mm
Weight	250 gs
Fastener Range	6 mm
Capacity	50 pcs

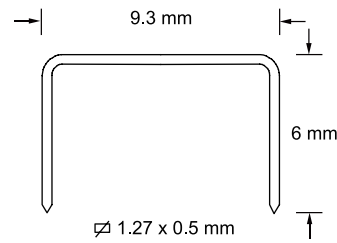

## APPLICATION

- Excellent for sealing small boxes and papers

## FEATURES

- All steel construction



## Cordless Auto Feed Screwdriver

Model No: TD1425LIL2-1, TD1825LIL2-1, TD1425LIH2-1, TD1825LIH2-1



### APPLICATION

- Drywall to Wood
- Drywall to light Ga. Steel
- Drywall to Heavy Ga. Steel
- Decking - Wood to Wood
- Flooring - Plywood to Wood
- Wood Flooring, Underlayment
- Composite Decking, Cement Board

### FEATURES

- Feeds screws continuously or individually
- Slide-in battery
- Battery power indication
- Accurate and reliable auto feeding mechanism for maximum and fast works
- Screw Guard to prevent interfere during operation
- Super treatment bits to last longest life
- High torque motor and high efficiency
- Light-Weight
- Forward and reverse switch
- Convenient belt hook
- Silent clutch
- Trigger lock for continuous work
- Rubber grip for comfort
- Reverse button for releasing collated screws
- Tool-Free screw length adjustment
- Tool-Free screw depth adjustment dial
- Vary adapters available for different brand power tool
- High efficiency fan cooled and changeable carbon brush motor

Model No	TD1425LIL2-1	TD1425LIH2-1	TD1825LIL2-1	TD1825LIH2-1
Description				
L x W x H	319x80x254 mm			
Weight	2.16 kgs	2.14 kgs	2.28 kgs	2.26 kgs
Voltage	14.4 V d.c.		18.0 V d.c.	
No-Load Speed	1900 RPM	4500 RPM	1600 RPM	4000 RPM
MAX. Torque	102kg-cm/10N.m/7.4ft-lb	82kg-cm/8N.m/5.9ft-lb	112kg-cm/11N.m/8.1ft-lb	92kg-cm/9N.m/6.6ft-lb
Fastener Range	16~25 mm			
Charging Time	40 min		50 min	
Battery Ampacity	2000 mAh			
Battery Pack	Li-Ion Sliding			
Driver Bit	⊕ PHILLIPS ⊕ POZI			
Bit Spec	1/4" x 124 mm			
Fastener Capacity	50 pcs			

## Cordless Auto Feed Screwdriver

Model No: TD1455LIL2-1, TD1455LIH2-1, TD1855LIL2-1, TD1855LIH2-1



### APPLICATION

- Drywall to Wood
- Drywall to light Ga. Steel
- Drywall to Heavy Ga. Steel
- Decking - Wood to Wood
- Flooring - Plywood to Wood
- Wood Flooring, Underlayment
- Composite Decking, Cement Board

### FEATURES

- Feeds screws continuously or individually
- Slide-in battery
- Battery power indication
- Accurate and reliable auto feeding mechanism for maximum and fast works
- Screw Guard to prevent interfere during operation
- Super treatment bits to last longest life
- High torque motor and high efficiency
- Light-Weight
- Forward and reverse switch
- Convenient belt hook
- Silent clutch
- Trigger lock for continuous work
- Rubber grip for comfort
- Reverse button for releasing collated screws
- Tool-Free screw length adjustment
- Tool-Free screw depth adjustment dial
- Vary adapters available for different brand power tool
- High efficiency fan cooled and changeable carbon brush motor

Model No	TD1455LIL2-1	TD1455LIH2-1	TD1855LIL2-1	TD1855LIH2-1
Description				
L x W x H	376x80x254 mm			
Weight	2.19 kgs	2.71 kgs	2.31 kgs	2.29 kgs
Voltage	14.4 V d.c.		18.0 V d.c.	
No-Load Speed	1900 RPM	4500 RPM	1600 RPM	4000 RPM
MAX. Torque	102kg-cm/10N.m/7.4ft-lb	82kg-cm/8N.m/5.9ft-lb	112kg-cm/11N.m/8.1ft-lb	92kg-cm/9N.m/6.6ft-lb
Fastener Range	25~55 mm			
Charging Time	40 min		50 min	
Battery Ampacity	2000 mAh			
Battery Pack	Li-Ion Sliding			
Driver Bit	⊕ PHILLIPS ⊕ POZI			
Bit Spec	1/4" x 154 mm			
Fastener Capacity	50 pcs			



## Cordless 2-Speed Auto Feed Screwdriver

Model No: TD1825LIH3, TD1855LIH3

16-25 mm Attachment & 25-55 mm Attachment are Available  
For collated screws

For loose screws



### APPLICATION

- Drywall to Wood
- Drywall to light Ga. Steel
- Drywall to Heavy Ga. Steel
- Decking - Wood to Wood
- Flooring - Plywood to Wood
- Wood Flooring
- Underlayment
- Composite Decking
- Cement Board

### FEATURES

- Variable speed trigger
- High/low speed two in one machine
- Quick release Attachment
- High torque
- Both 25-55mm or 16-25mm fastener range are available

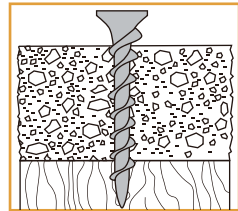

Drywall to wood

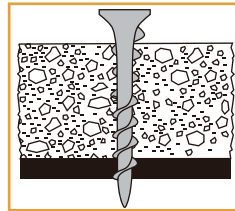

Drywall to Heavy Gauge Steel

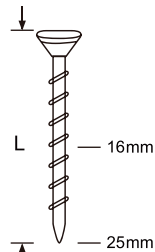

TD1825LIH3

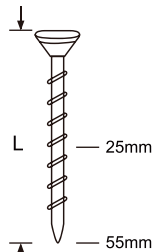

TD1855LIH3

Model No	TD1825LIH3	TD1855LIH3
Description		
L x W x H	407x80x262 mm	
Weight	1.86 kgs	
Voltage	18.0 V d.c.	
No-Load Speed	High Torque Mode:0~1800 RPM High Speed Mode:0~5000 RPM	
MAX. Torque	L:142kg-cm/ 14 N.m/ 7.4 ft-lb H:102kg-cm/ 10 N.m/ 10.3 ft-lb	
Fastener Range	16~25 mm	25~55 mm
Bit Spec	1/4" x 173L	

## Extension Bar

Model No: EB700

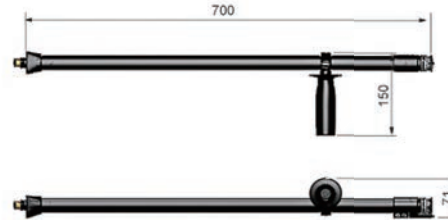

Model No	EB700
L x W x H	700x150x71 mm
Weight	2.5 kgs

### APPLICATION

- Drywall to wood
- Drywall to light Ga. Steel
- Drywall to heavy Ga. Steel
- Decking - Wood to Wood
- Flooring - Plywood to Wood
- Wood Flooring
- Underlayment
- Composite Decking
- Cement Board
- Ceilings, Floors

### FEATURES

- The T-bar handle at the extension bar for easier driving in floors and ceilings, screw strip quiver, and soft carry bag



CARRY BAG



## Powder Actuated Tool

Model No: D450

■ All Spare Parts Are Compatible With Hilti DX450



VARIOUS PISTONS ARE AVAILBLE

Model No	D450
L x W x H	350x55x180 mm
Weight	3.2 kgs
Cartridge	6.8/11 mm Black, Red, Yellow, Green



### APPLICATION

- Wood and metal to concrete or steel
- Electrical installations (switchboxes)
- Mouldings brackets, sections etc
- General and special contractors
- Plant maintenance
- Woodworking, electrical installation
- Mechanical installation (plumbing, heating and air conditioning)
- Clips, clamps and rings for electric cables, conduits and pipes
- Interior finishing
- Plastering

### FEATURES

- This powder-actuated tool has a report silencer, power regulation and automatic cartridge feed
- It is suitable for a wide range of fastenings to steel, concrete and hard masonry
- With this piston tool, fasteners cannot ricochet or be shot through walls
- In addition, contact, drop firing and loading safety devices ensure absolute safety for the operator
- Supplied in a tough plastic tool box with safety and cleaning equipment in the standard kit



# Aluminum Refillable Spray Can

Model No: AR250, AR100



Patented in The U.S.A  
Taiwan, Japan and China

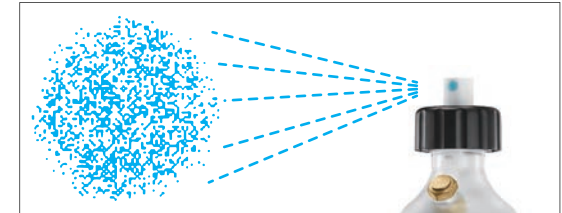

Full cone spray

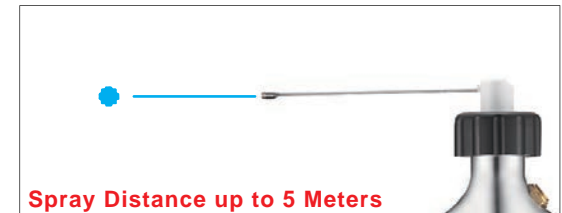

Spray Distance up to 5 Meters

Solid stream spray

Demo. Spray can

Model No	AR250	AR100
Capacity	250 ml (8-1/2 oz)	100 ml (3-1/2 oz)
Pressure	120 psi	
O.D	60 mm	52.3 mm
Height	270 mm	190 mm
Weight	0.4 kgs	0.35 kgs
Material	Aluminum	

## APPLICATION

- Auto/Truck & Motorsports
- Automotive Maintenance & Repair
- Boating & Watersports
- Construction
- Farming
- Garage / Workshop
- Hobby & Crafts
- Home & Garden
- Maintenance, Repair & Overhaul
- HVAC
- On The Job
- Sports & Recreation
- Drives Out Moisture
- Protects
- Frees Sticky Mechanisms
- Loosens Rusted Parts
- Removes
- Lubricates

## FEATURES

- Easy loading
- Easy cleaning
- Superb light
- Two spray nozzles, full cone spray and solid stream spray
- Economic
- Eco-Friendly
- Reuse for countless times
- Ideal for industrial lubricants, WD-40...etc
- Multipurpose





# Patented 720° Rotation Quick Couplers

Model No: FRQ14, MRQ14, MRQ38

## APPLICATION

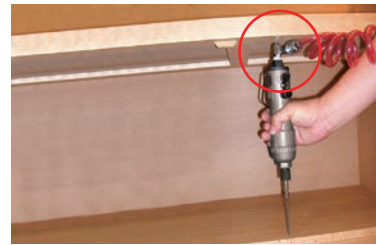

Using traditional quick couplers

Using rotational quick coupler  
**No dead angle**



FRQ14:1/4"



MRQ14:1/4"



MRQ38:3/8"

## FEATURES

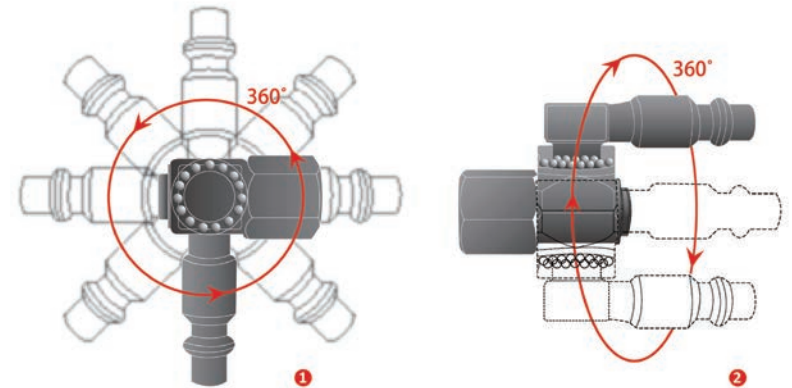

- User-friendly, no need extra tools in job-site.
- Safety and working freely.
- Operate without dead angle, no bending air hose at any direction.
- Extra value and saving money.
- Extending lifetime of air hose and coupler.

## INSTRUCTIONS

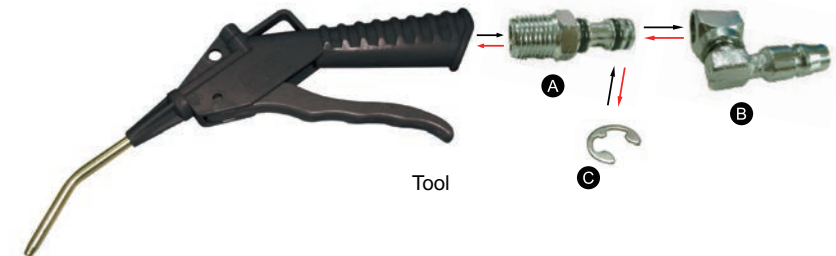

- Assembly instruction: Screw part A into tool (O-ring with lubricative oil), then insert part B into part A. then lock part C into part A.
- Disassemble sequence: Remove part C, then remove part B before taking part A from tool.





## Carton Supporters

Model No: SS01, LS02, SP03



Small Supporter With Stand



Large Supporter With Stand

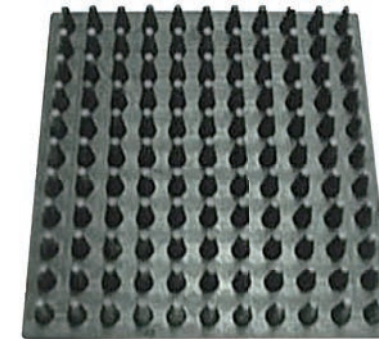

Supporter Plate

Model No	Small Supporter With Stand - SS01	Large Supporter With Stand - LS02	Supporter Plate - SP03
L x W x H	420x420x730 mm	420x450x730 mm	220x220x30 mm
Weight	9 kgs	10 kgs	0.45 kgs

### APPLICATION

- Box Support let your working process smoother and more efficient.





## OIL-LESS Air Compressor

Model No: CG3012



## OIL-LUBE Air Compressor

Model No: CG2520



Model No	CG3012
L x W x H	500x370x680 mm
Net Weight	29 kgs
HP/kW	3HP
Air Delivery	195 L/min
R.P.M	2850 RPM
Capacity	12 L
Working Pressure	6 Bar
Max Pressure	8 Bar
Pump Type	Oil-Less

### FEATURES

- Compact and portable designs
- Oil-less models feature patented pump design for lower noise and improved cooling
- Maintenance-free on oil-less units
- All models are equipped with induction motors with overload protection
- Ideal for home and professional applications

Model No	CG2520
L x W x H	590x690x530 mm
Net Weight	41 kgs
HP/kW	2.5HP
Air Delivery	217 L/min
R.P.M	2850 RPM
Capacity	20 L
Working Pressure	6 Bar
Max Pressure	8 Bar
Pump Type	Oil-Lube

### FEATURES

- Compact and portable designs
- Oil-lube models feature "monobloc" die-cast aluminum pump with cast iron cylinder
- All models are equipped with induction motors with overload protection
- Ideal for home and professional applications



## OIL-LESS Air Compressor

Model No: VL2015



## OIL-LUBE Air Compressor

Model No: CG2016



Model No	VL2015
L x W x H	600x500x480 mm
Net Weight	44.5 kgs
HP/kW	2HP
Air Delivery	180 L/min
R.P.M	1400 RPM
Capacity	15 L
Working Pressure	6 Bar
Max Pressure	8 Bar
Pump Type	Oil-Less

### FEATURES

- Compact and portable designs
- Oil-less models feature patented pump design for lower noise and improved cooling
- Maintenance-free on oil-less units
- All models are equipped with induction motors with overload protection
- Ideal for home and professional applications

Model No	CG2016
L x W x H	490x480x480 mm
Net Weight	34 kgs
HP/kW	2HP
Air Delivery	174 L/min
R.P.M	2850 RPM
Capacity	16 L
Working Pressure	6 Bar
Max Pressure	8 Bar
Pump Type	Oil-Lube

### FEATURES

- Compact and portable designs
- Oil-lube models feature "monobloc" die-cast aluminum pump with cast iron cylinder
- All models are equipped with induction motors with overload protection
- Ideal for home and professional applications



## OIL-LESS Air Compressor

Model No: CG1505



## OIL-LUBE Air Compressor

Model No: CG1510



Model No	CG1505
L x W x H	390x380x300 mm
Net Weight	19.5 kgs
HP/kW	1.5HP
Air Delivery	50 Hz:108 L/min 60 Hz:130 L/min
R.P.M	50 Hz:2850 RPM 60 Hz:3450 RPM
Capacity	12 L
Working Pressure	6 Bar
Max Pressure	8 Bar
Pump Type	Oil-Less

### FEATURES

- Compact and portable designs
- Oil-less models feature patented pump design for lower noise and improved cooling
- Maintenance-free on oil-less units
- All models are equipped with induction motors with overload protection
- Ideal for home and professional applications

Model No	CG1510
L x W x H	540x200x580 mm
Net Weight	25 kgs
HP/kW	1.5HP
Air Delivery	111 L/min
R.P.M	1450 RPM
Capacity	10 L
Working Pressure	6 Bar
Max Pressure	8 Bar
Pump Type	Oil-Lube

### FEATURES

- Compact and portable designs
- Oil-lube models feature "monobloc" die-cast aluminum pump with cast iron cylinder
- All models are equipped with induction motors with overload protection
- Ideal for home and professional applications



## OIL-LESS Air Compressor

Model No: CG1012



## OIL-LESS Air Compressor

Model No: CG1010



Model No	CG1012
L x W x H	480x390x390 mm
Net Weight	20.4 kgs
HP/kW	1HP
Air Delivery	125 L/min
R.P.M	1400 RPM
Capacity	12 L
Working Pressure	6 Bar
Max Pressure	8 Bar
Pump Type	Oil-Less

### FEATURES

- Compact and portable designs
- Running stably and low noise
- Maintenance-free on oil-less units
- High efficiency
- Ideal for home and professional applications

Model No	CG1010
L x W x H	540x220x610 mm
Net Weight	25 kgs
HP/kW	1HP
Air Delivery	92 L/min
R.P.M	2850 RPM
Capacity	10 L
Working Pressure	6 Bar
Max Pressure	8 Bar
Pump Type	Oil-Less

### FEATURES

- Compact and portable designs
- Oil-less models feature patented pump design for lower noise and improved cooling
- Maintenance-free on oil-less units
- All models are equipped with induction motors with overload protection
- Ideal for home and professional applications



## OIL-LESS Air Compressor

Model No: CG1025



## OIL-LESS Air Compressor

Model No: CG1050



Model No	CG1025
L x W x H	590x290x610 mm
Net Weight	24 kgs
HP/kW	1HP
Air Delivery	125 L/min
R.P.M	1400 RPM
Capacity	25 L
Working Pressure	6 Bar
Max Pressure	8 Bar
Pump Type	Oil-Less

### FEATURES

- Compact and portable designs
- Running stably and low noise
- Maintenance-free on oil-less units
- High efficiency
- Ideal for home and professional applications

Model No	CG1050
L x W x H	780x380x780 mm
Net Weight	70 kgs
HP/kW	1HP
Air Delivery	360 L/min
R.P.M	1400 RPM
Capacity	50 L
Working Pressure	6 Bar
Max Pressure	8 Bar
Pump Type	Oil-Less

### FEATURES

- Compact and portable designs
- Running stably and low noise
- Maintenance-free on oil-less units
- High efficiency
- Ideal for home and professional applications





## OIL-LESS Air Compressor

Model No: CG1006



## OIL-LESS Air Compressor

Model No: CG1004



Model No	CG1006
L x W x H	450x190x420 mm
Net Weight	13 kgs
HP/kW	1HP
Air Delivery	92 L/min
R.P.M	2850 RPM
Capacity	6 L
Working Pressure	6 Bar
Max Pressure	8 Bar
Pump Type	Oil-Less

### FEATURES

- Compact and portable designs
- Oil-less models feature patented pump design for lower noise and improved cooling
- Maintenance-free on oil-less units
- All models are equipped with induction motors with overload protection
- Ideal for home and professional applications

Model No	CG1004
L x W x H	370x340x340 mm
Net Weight	14.3 kgs
HP/kW	1HP
Air Delivery	95 L/min
R.P.M	1400 RPM
Capacity	4 L
Working Pressure	6 Bar
Max Pressure	8 Bar
Pump Type	Oil-Less

### FEATURES

- Compact and portable designs
- Oil-less models feature patented pump design for lower noise and improved cooling
- Maintenance-free on oil-less units
- All models are equipped with induction motors with overload protection
- Ideal for home and professional applications



## OIL-LESS Air Compressor

Model No: CG3405



## OIL-LESS Air Compressor

Model No: CG05041



Model No	CG3405
L x W x H	410x350x270 mm
Net Weight	14.8 kgs
HP/kW	3/4HP
Air Delivery	95 L/min
R.P.M	1400 RPM
Capacity	5 L
Working Pressure	6 Bar
Max Pressure	8 Bar
Pump Type	Oil-Less

### FEATURES

- Compact and portable designs
- Running stably and low noise
- Maintenance-free on oil-less units
- High efficiency
- Ideal for home and professional applications

Model No	CG05041
L x W x H	360x330x310 mm
Net Weight	9.3 kgs
HP/kW	1/2HP
Air Delivery	34 L/min
R.P.M	2850 RPM
Capacity	4 L
Working Pressure	8 kg/cm <sup>2</sup>
Max Pressure	10 kg/cm <sup>2</sup>
Pump Type	Oil-Less

### FEATURES

- Compact and portable designs
- Oil-less models feature patented pump design for lower noise and improved cooling
- Maintenance-free on oil-less units
- All models are equipped with induction motors with overload protection
- Ideal for home and professional applications



## OIL-LESS Air Compressor

Model No: CG05042



## OIL-LESS Air Compressor

Model No: CG05043



Model No	CG05042
L x W x H	410x260x340 mm
Net Weight	11 kgs
HP/kW	1/2HP
Air Delivery	45 L/min
R.P.M	2850 RPM
Capacity	4 L
Working Pressure	6 Bar
Max Pressure	8 Bar
Pump Type	Oil-Less

### FEATURES

- Compact and portable designs
- Oil-less models feature patented pump design for lower noise and improved cooling
- Maintenance-free on oil-less units
- All models are equipped with induction motors with overload protection
- Ideal for home and professional applications

Model No	CG05043
L x W x H	370x360x325 mm
Net Weight	12 kgs
HP/kW	1/2HP
Air Delivery	34 L/min
R.P.M	2850 RPM
Capacity	4 L
Working Pressure	6 Bar
Max Pressure	8 Bar
Pump Type	Oil-Less

### FEATURES

- Compact and portable designs
- Oil-less models feature patented pump design for lower noise and improved cooling
- Maintenance-free on oil-less units
- All models are equipped with induction motors with overload protection
- Ideal for home and professional applications



**OIL-LESS Air Compressor**  
Model No: CG05044



Model No	CG05044
L x W x H	370x360x325 mm
Net Weight	12 kgs
HP/kW	1/2HP
Air Delivery	34 L/min
R.P.M	2850 RPM
Capacity	4 L
Working Pressure	6 Bar
Max Pressure	8 Bar
Pump Type	Oil-Less

**FEATURES**

- Compact and portable designs
- Oil-less models feature patented pump design for lower noise and improved cooling
- Maintenance-free on oil-less units
- All models are equipped with induction motors with overload protection
- Ideal for home and professional applications



# Spring Driven Hose Reel

Model No: HR01U Series



## APPLICATIONS

- Light and convenient, the product is suitable for any pneumatic tools
- Easy to use for home DIY and/or manufacturing
- Used for construction work areas

Use the hook to hang or hook to the wall or the ceiling



## FEATURES

- Casing made of impact resistant ABS plastic
- Spring operated rewinding mechanism  
Close case type
- Automatic hose reel for compressor
- Working temperature: -5°C ~ +60°C
- Single packaging size :240 x 215 x 95 mm (LxWxH)
- Weight: 1.4kg
- Measurement: 0.18 cuft/set, 10 sets in a master carton 48.5 x 25 x 45 cm (LxWxH)

## SPECIFICATIONS

- Supplied with sling hook, mounting frame and hardware

## PACKAGING

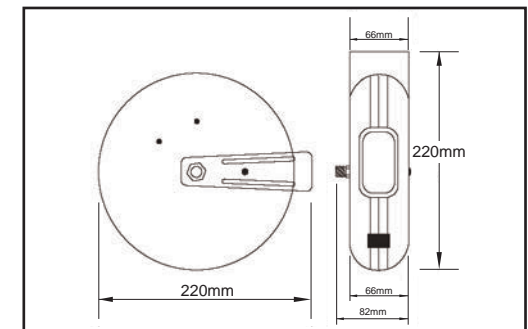

Model No.	Hose I.D. (mm)	MAX WORKING PRESSURE AT 23° C (75° F)	BURSTING PRESSURE AT 23° C (75° F)	HOSE LENGTH (outlet)	HOSE TYPE	FITTING THREAD SIZE (inlet+outlet)	WEIGHT (N.W.)
HR01U5075	5.0 mm	8 bar	24 bar	7.5 m	Pu	1/4 + 1/4	1.4 kgs
HR01UB5075	5.0 mm	15 bar	45 bar	7.5 m	Pu Braid	1/4 + 1/4	1.4 kgs
HR01U6560	6.5 mm	8 bar	24 bar	6 m	Pu	1/4 + 1/4	1.4 kgs
HR01UB6560	6.5 mm	15 bar	45 bar	6 m	Pu Braid	1/4 + 1/4	1.4 kgs

Case Standard Color	Hose Standard Color	Hose Size	Packing Dimension	Container Pack	Fitting Thread
Yellow	Orange	5x8 mm/6.5x10 mm	24x21.5x9.5 cm	5000 pcs/20 ft	BSPT / NPT



## Manual Driven Hose Reel

Model No: HR01 Series

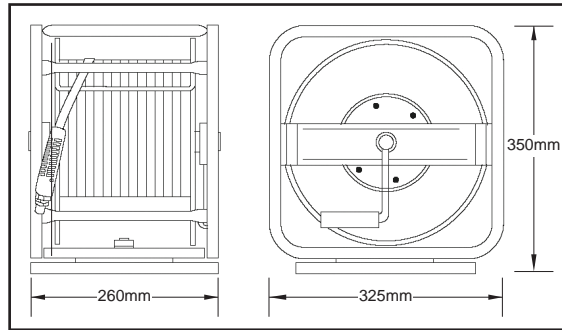
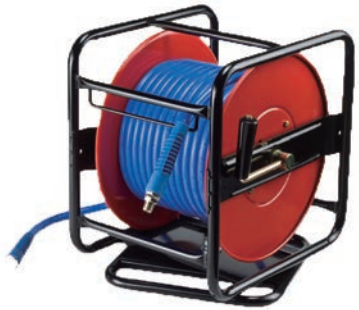

Model No.	Hose I.D. (mm/inch)	MAX WORKING PRESSURE AT 23° C (bar/psi)	BURSTING PRESSURE AT 23° C (bar/psi)	LEAD HOSE LENGTH (inlet)	HOSE LENGTH (outlet)	HOSE TYPE	FITTING THREAD SIZE (inlet+outlet)	WEIGHT
HR01-UB6520	6.5 mm (1/4")	15 / 200	60 / 800	110 cm	20 m	Pu Braid	1/4 + 1/4	6.7 kgs
HR01-UB6530					30 m			7.5 kgs
HR01-UB6540					40 m			8.3 kgs
HR01-UB6550					50 m			9.0 kgs
HR01-UB8020	8.0 mm (5/16")	15 / 200	60 / 800	110 cm	20 m	Pu Braid	1/4 + 1/4	7.0 kgs
HR01-UB8030					30 m			8.0 kgs
HR01-UB8040					40 m			9.0 kgs
HR01-UB8520	8.5mm	15 / 200	60 / 800	110 cm	20 m	Pu Braid	1/4 + 1/4	7.0 kgs
HR01-UB8530					30 m			8.0 kgs
HR01-UB8540					40 m			9.0 kgs
HR01-UB9520	9.5 mm (3/8")	15 / 200	60 / 800	110 cm	20 m	Pu Braid	3/8 + 3/8	8.0 kgs
HR01-UB9525					25 m			8.5 kgs
HR01-UB9530					30 m			9.0 kgs
HR01-UB1020	10 mm	15 / 200	60 / 800	110 cm	20 m	Pu Braid	3/8 + 3/8	8.0 kgs
HR01-UB1030					30 m			9.0 kgs
HR01-UB1130	11 mm	15 / 200	60 / 800	110 cm	30 m	Pu Braid	3/8 + 3/8	10 kgs

## Manual Driven Hose Reel

Model No: HR02 Series

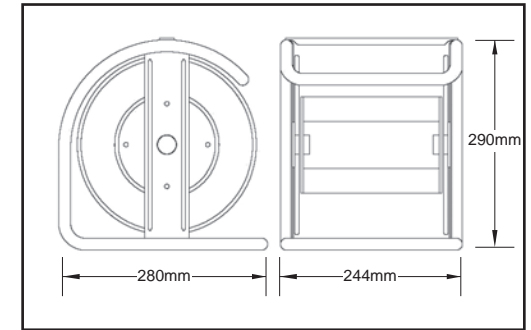
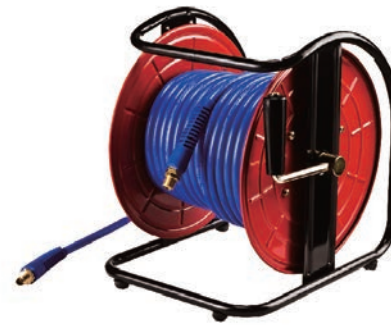

Model No.	Hose I.D. (mm/inch)	MAX WORKING PRESSURE AT 23° C (bar/psi)	BURSTING PRESSURE AT 23° C (bar/psi)	LEAD HOSE LENGTH (inlet)	HOSE LENGTH (outlet)	HOSE TYPE	FITTING THREAD SIZE (inlet+outlet)	WEIGHT
HR02-UB6520	6.5 mm (1/4")	15 / 200	60 / 800	110 cm	20 m	Pu Braid	1/4 + 1/4	5.0 kgs
HR02-UB6525					25 m			5.0 kgs
HR02-UB6530					30 m			5.0 kgs
HR02-UB8010	8.0 mm (5/16")	15 / 200	60 / 800	110 cm	10 m	Pu Braid	1/4 + 1/4	5.3 kgs
HR02-UB8015					15 m			5.3 kgs
HR02-UB8020					20 m			5.3 kgs
HR02-UB9510	9.5 mm (3/8")	15 / 200	60 / 800	110 cm	10 m	Pu Braid	3/8 + 3/8	5.5 kgs
HR02-UB9515					15 m			5.5 kgs
HR02-UB9520					20 m			5.5 kgs



## Manual Driven Hose Reel

Model No: HR03 Series

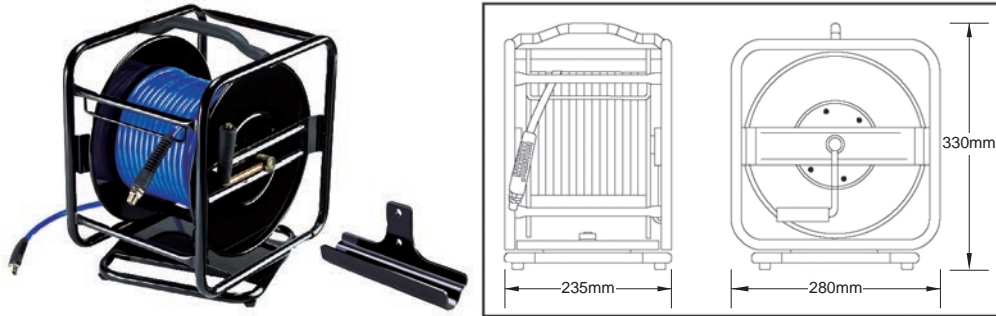

Model No.	Hose I.D. (mm/inch)	MAX WORKING PRESSURE AT 23° C (bar/psi)	BURSTING PRESSURE AT 23° C (bar/psi)	LEAD HOSE LENGTH (inlet)	HOSE LENGTH (outlet)	HOSE TYPE	FITTING THREAD SIZE (inlet+outlet)	WEIGHT
HR03-UB6520	6.5 mm (1/4")	15 / 200	60 / 800	110 cm	20 m	Pu Braid	1/4 + 1/4	7.7 kgs
HR03-UB6530					30 m			8.5 kgs
HR03-UB6540					40 m			9.3 kgs
HR03-UB8020	8.0 mm (5/16")	15 / 200	60 / 800	110 cm	20 m	Pu Braid	1/4 + 1/4	8.0 kgs
HR03-UB8030					30 m			9.0 kgs
HR03-UB8520	8.5mm	15 / 200	60 / 800	110 cm	20 m	Pu Braid	1/4 + 1/4	8.0 kgs
HR03-UB8530					30 m			9.0 kgs
HR03-UB9520	9.5 mm (3/8")	15 / 200	60 / 800	110 cm	20 m	Pu Braid	3/8 + 3/8	7.0 kgs
HR03-UB9525					25 m			7.5 kgs
HR03-UB9530					30 m			8.0 kgs
HR03-UB1020	10 mm	15 / 200	60 / 800	110 cm	20 m	Pu Braid	3/8 + 3/8	9.0 kgs

## Manual Driven Hose Reel

Model No: HR04 Series

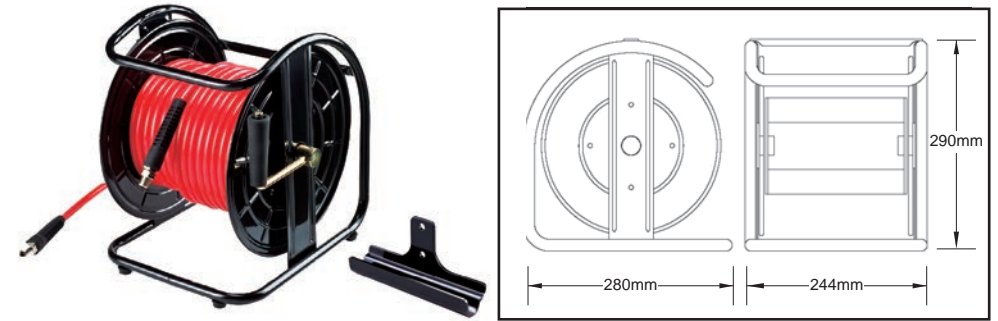

Model No.	Hose I.D. (mm/inch)	MAX WORKING PRESSURE AT 23° C (bar/psi)	BURSTING PRESSURE AT 23° C (bar/psi)	LEAD HOSE LENGTH (inlet)	HOSE LENGTH (outlet)	HOSE TYPE	FITTING THREAD SIZE (inlet+outlet)	WEIGHT
HR04-UB6520	6.5 mm (1/4")	15 / 200	60 / 800	110 cm	20 m	Pu Braid	1/4 + 1/4	6.0 kgs
HR04-UB6525					25 m			6.0 kgs
HR04-UB6530					30 m			6.0 kgs
HR04-UB8010	8.0 mm (5/16")	15 / 200	60 / 800	110 cm	10 m	Pu Braid	1/4 + 1/4	6.3 kgs
HR04-UB8015					15 m			6.3 kgs
HR04-UB8020					20 m			6.3 kgs
HR04-UB9510	9.5 mm (3/8")	15 / 200	60 / 800	110 cm	10 m	Pu Braid	3/8 + 3/8	6.5 kgs
HR04-UB9515					15 m			6.5 kgs
HR04-UB9520					20 m			6.5 kgs



## Spring Driven Hose Reel

Model No: HR05 Series

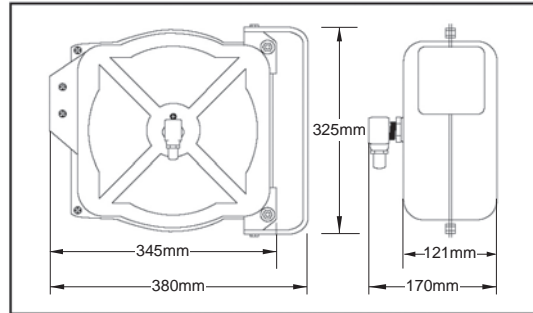

Model No.	Hose I.D. (mm/inch)	MAX WORKING PRESSURE AT 23° C (bar/psi)	BURSTING PRESSURE AT 23° C (bar/psi)	HOSE LENGTH (inlet)	HOSE LENGTH (outlet)	HOSE TYPE	FITTING THREAD SIZE (inlet+outlet)	WEIGHT
HR05-UB6510	6.5 mm (1/4")	15 bar	60 bar	50 cm	10 m	Pu Braid	1/4 + 1/4	8.0 kgs
HR05-UB6515					15 m			8.0 kgs
HR05-UB8010	8.0 mm (5/16")	15 bar	60 bar	50 cm	10 m	Pu Braid	1/4 + 1/4	9.0 kgs
HR05-UB8012					12m			9.0 kgs
HR05-UB9510	9.5 mm (3/8")	15 bar	60 bar	50 cm	10 m	Pu Braid	3/8 + 3/8	9.5 kgs
HR05-UB1008	10 mm	15 bar	60 bar	50 cm	8 m	Pu Braid	3/8 + 3/8	9.2 kgs

## Hand Crank Hose Reel

Model No: HR100516, HR65638



### FEATURES

- Lightweight & portable-good for furniture & wooded material decoration
- Cost effective

Model No	HR100516	HR65638
Hose Size (inch)	5/16"	3/8"
Length (FT/M)	100/30	65.6/20
Hose Color	Blue	Blue
Hose	PU Braid Hose	PU Braid Hose





## Air Hose Reel In Steel Case

Model No: HR50516, HR4038, HR5038



### FEATURES

- Steel case increases durability
- Easily installing on the wall or the ceiling
- Installed reel can rotate within 190°
- Spring with good quality & strength roll back quickly & efficiently without fatigue
- Rolling dual test : 30,000 times
- Designed 2 holes on the hand bar easily to fix for firm installation

Model No	HR50516	HR4038	HR5038
Hose Size (inch)	5/16"	3/8"	3/8"
Length (FT/M)	50/15	40/12	50/15
Hose Color	Blue	Blue	Blue
Hose	PU Braid Hose	PU Braid Hose	PU Braid Hose

## Air Hose Reel In Plastic Case

Model No: HR1058, HR1258, HR106510, HR8812



### FEATURES

- Easily installing on the wall or the ceiling
- Installed reel can rotate within 190°
- Spring with good quality & strength roll back quickly & efficiently without fatigue
- Designed 2 holes on the hand bar easily to fix for firm installation

Model No	HR1058	HR1258	HR106510	HR8812
Hose Size (mm)	5x8	5x8	6.5x10	8x12
Length (M)	10	12	10	8
Hose Color	Blue	Blue	Blue	Blue
Hose	PU Braid Hose	PU Braid Hose	PU Braid Hose	PU Braid Hose



## Air Hose Reel

Model No: HR06 Series

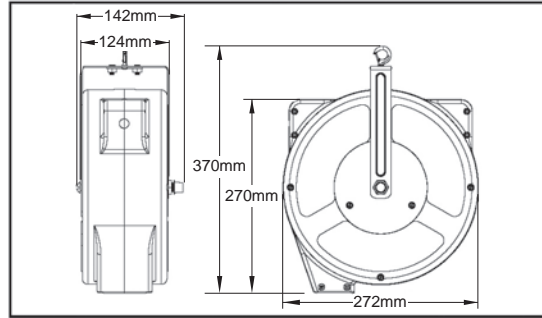

## Air Hose Reel

Model No: HR07 Series

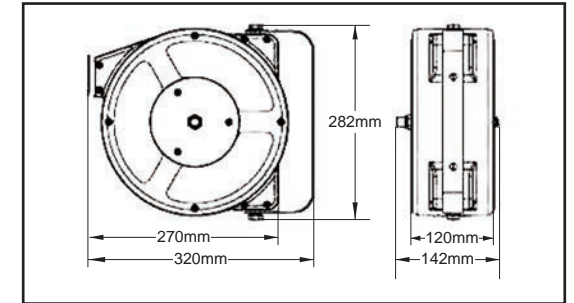

Model No.	Hose I.D. (mm/inch)	MAX WORKING PRESSURE AT 23° C (bar/psi)	BURSTING PRESSURE AT 23° C (bar/psi)	HOSE LENGTH (inlet)	HOSE LENGTH (outlet)	HOSE TYPE	FITTING THREAD SIZE (inlet+outlet)	WEIGHT
HR06-UB6508	6.5 mm (1/4")	15 bar	60 bar	50 cm	8 m	Pu Braid	1/4 + 1/4	3.3 kgs
HR06-UB6510					10 m			3.3 kgs
HR06-UB6512					12 m			3.3 kgs
HR06-UB8008	8.0 mm (5/16")	15 bar	60 bar	50 cm	8 m	Pu Braid	1/4 + 1/4	3.3 kgs

Model No.	Hose I.D. (mm/inch)	MAX WORKING PRESSURE AT 23° C (bar/psi)	BURSTING PRESSURE AT 23° C (bar/psi)	HOSE LENGTH (inlet)	HOSE LENGTH (outlet)	HOSE TYPE	FITTING THREAD SIZE (inlet+outlet)	WEIGHT
HR07-UB6508	6.5 mm (1/4")	15 bar	60 bar	50 cm	8 m	Pu Braid	1/4 + 1/4	3.3 kgs
HR07-UB6510					10 m			3.3 kgs
HR07-UB6512					12 m			3.3 kgs
HR07-UB8008	8.0 mm (5/16")	15 bar	60 bar	50 cm	8 m	Pu Braid	1/4 + 1/4	3.3 kgs



Free Artwork & Package Design are available



# Drive Pin

## Low Velocity Fasteners

EPD	PDL	FM	C9	CR9	PDCC	X-CC	DP	PDB
PD	NKDW	DN	PDIW	DD	PDCB	X-DN	X-PC	X-CCNK
PDJ	NK	EDN	PDW	TB	ENK	DNTC	PDCA	ZD
SPD	DNT	DZ	DNW	ENP	PDT	DNTW	DNJ	PDW-S

## Power Loads

S1	S3	S4	S5	S52	S42	S43











Powder loads from 6.8/11mm  
Black, Red, Yellow, Green









# Drive Pin



## High Velocity Fasteners

	
HPD	HTS6/HTS1/4"
	
HPD6	HEP6
	
HEP3/8	HPD 1/4
	
HEP 1/4	HPD8



## Threaded Studs

	
TS 3/8"	M4
	
TS 1/4"	M6
	
EM6/EM8/EM10	M8/M10

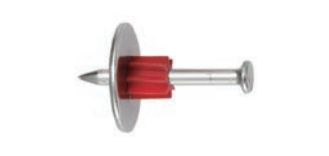
## Stainless Steel Fasteners



		
PD-SS(Stainless Steel)	DN-SS	PDW-SS

## Hammer Drive Pin

	
HM	MK

## Shooting Nails For PAT PT603

4.5x30,40,50,60,70,80 mm  
5.0x100 mm

		
---	---	---



## C-Ring, D-Ring, Omega Ring

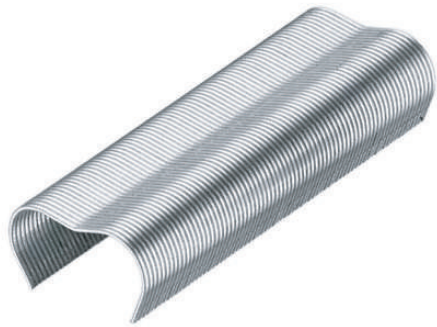

- HR22 For Rapid Garden HR22  
Crown : 36.8 mm  
Ø 1.2 x 1.3 mm



- VR38 For Rapid Garden Plier GP238  
Crown : 38 mm  
Ø 1.3 mm

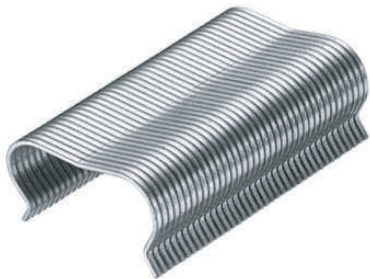

- E40 For SIMES MOD 150  
Crown : 39 mm  
Ø 2 mm



C-Ring, D-Ring and Omega Rings With Zinc Plated, Galvan, PVC Coated, Stainless Steel, Aluminium & Zinc - Aluminium.



Collated Screws & Chipboard, Drywall, Self Drilling and Tapping Screws

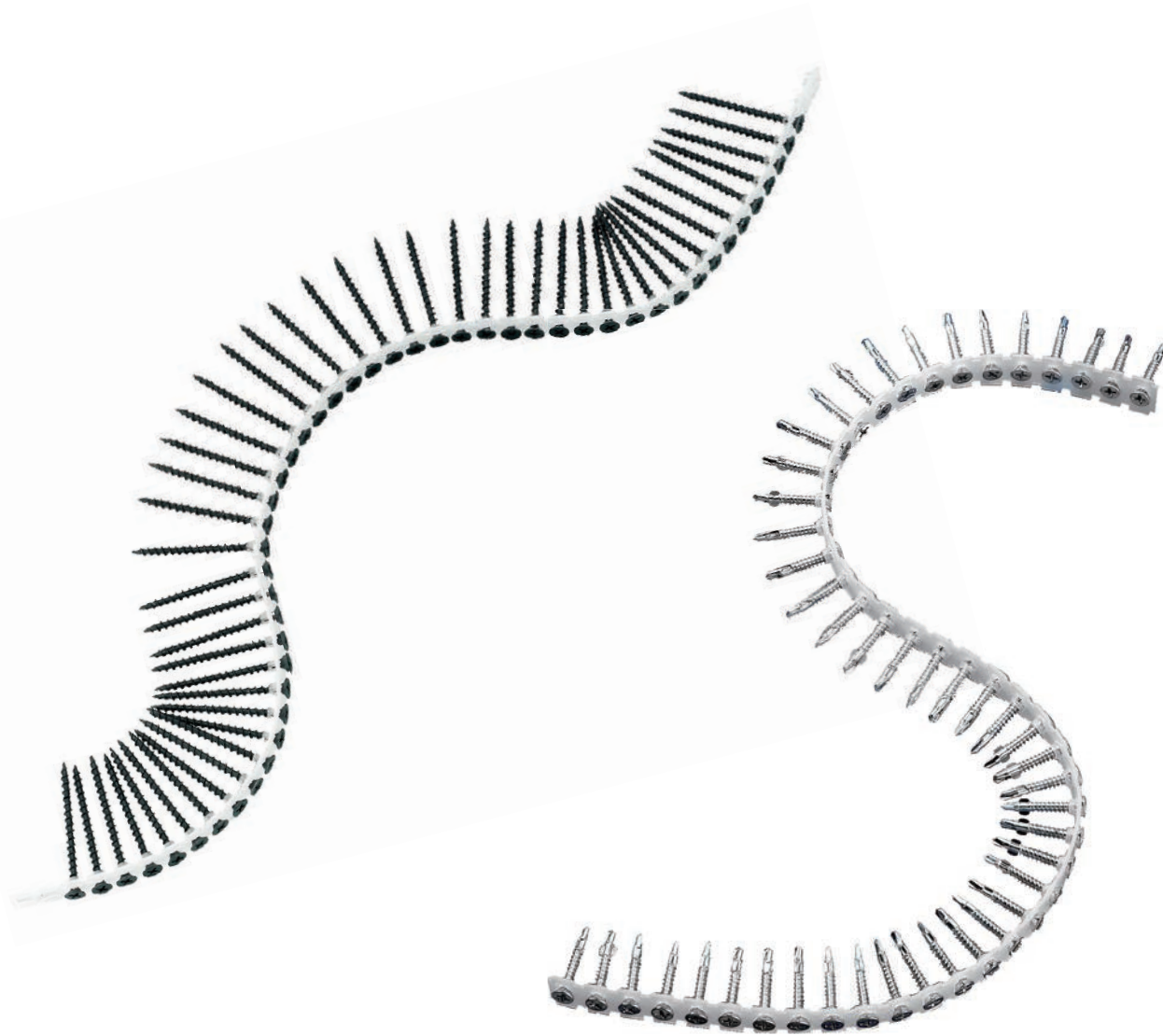

Self-Drilling Screws



Chipboard, Drywall, Tapping, Machine, Wood Screws



## Pin Nails, Brads

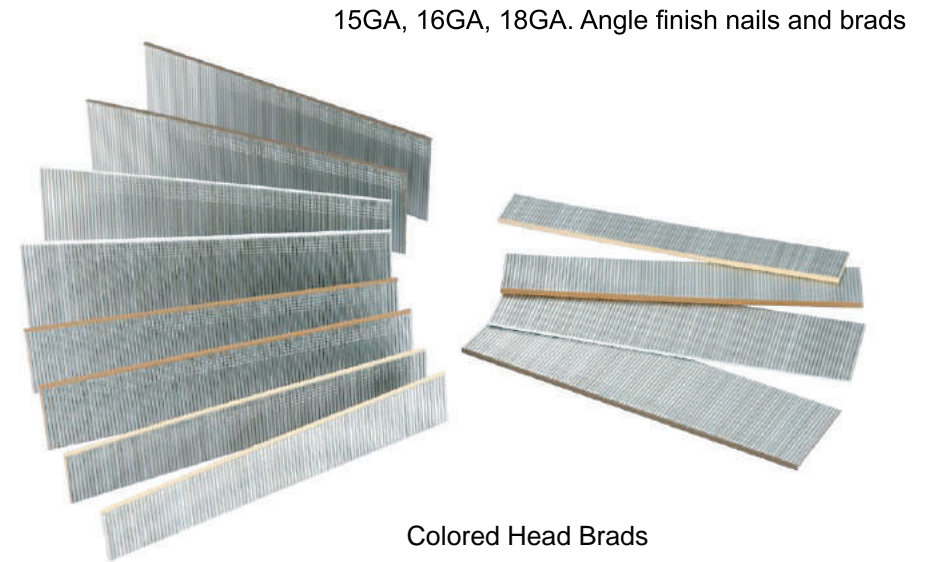
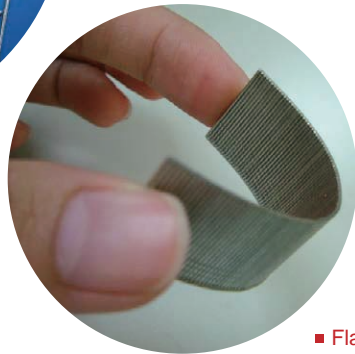
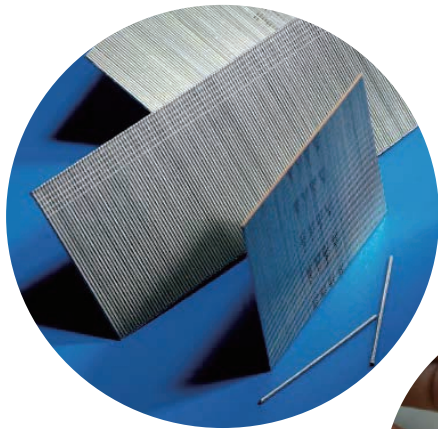
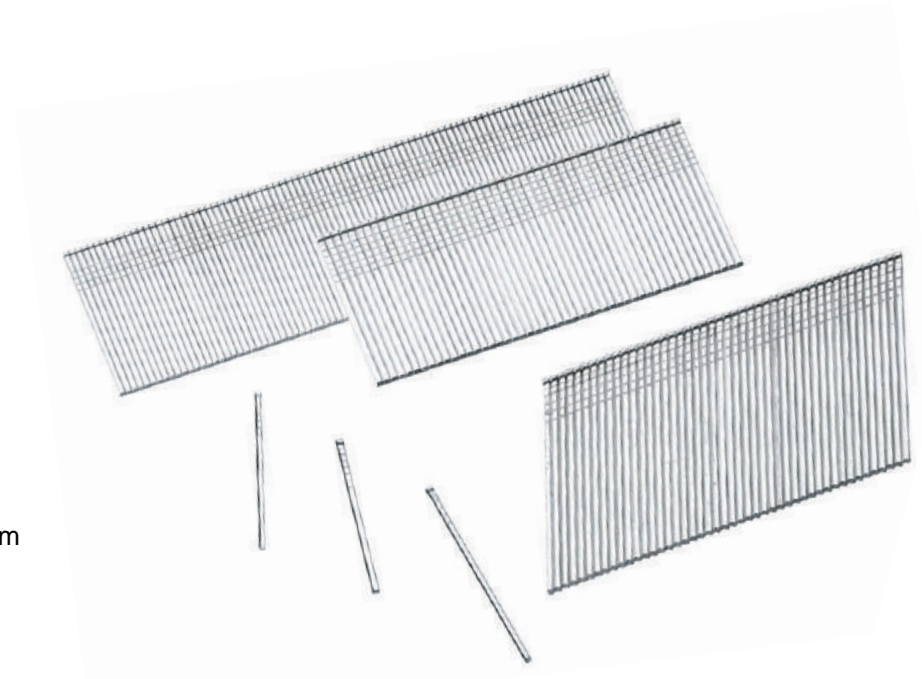
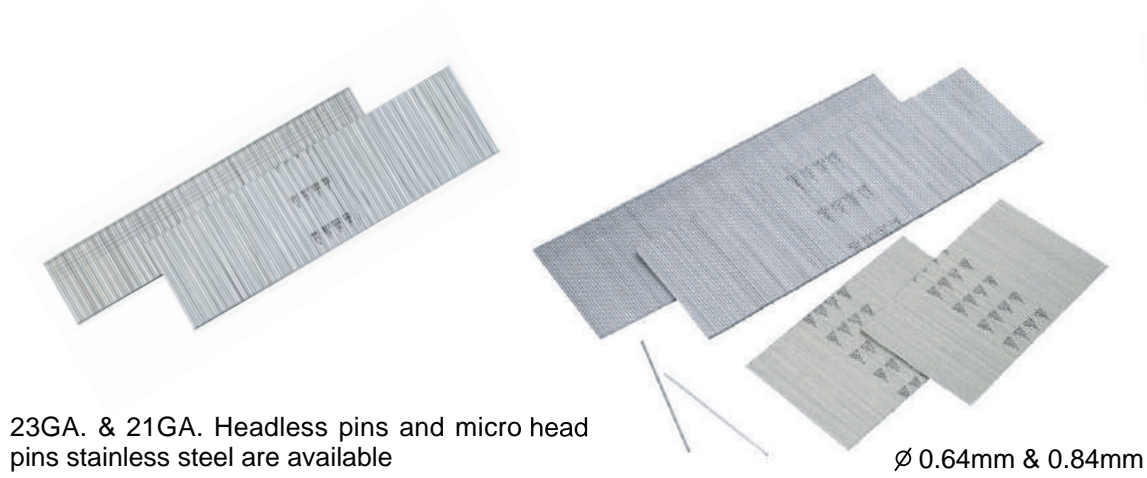



# T Nails, Flooring Cleats

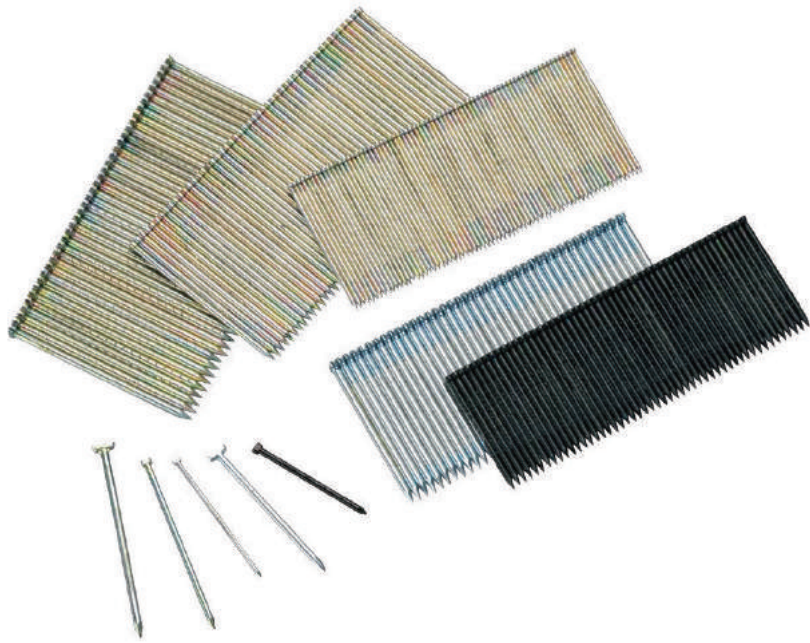

Flooring cleats and power nails

Glued Type High and Low Carbon Steel T Nails

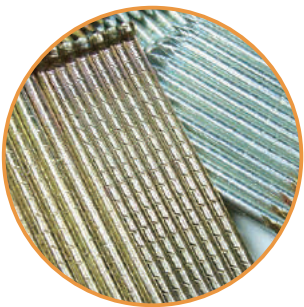

■ Nail's shank with deep groove

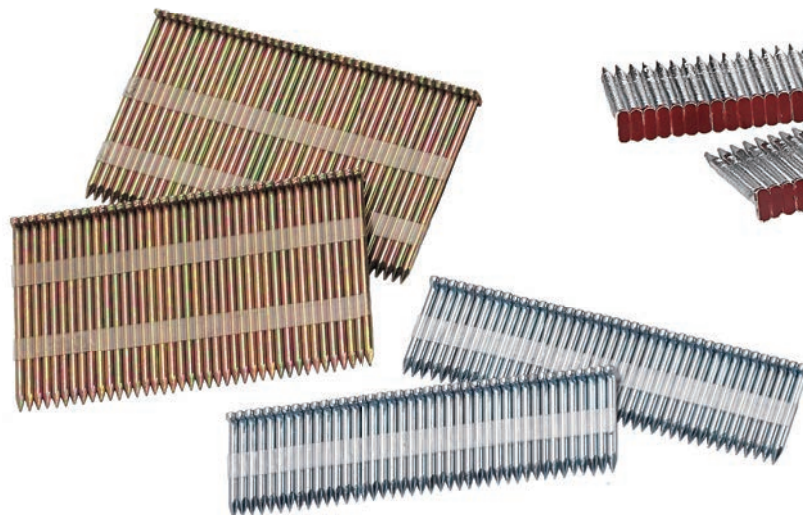

Taped Type High & Low Carbon Steel T Nails



High Carbon Steel T Nails with Painted Head



## Strip Nails

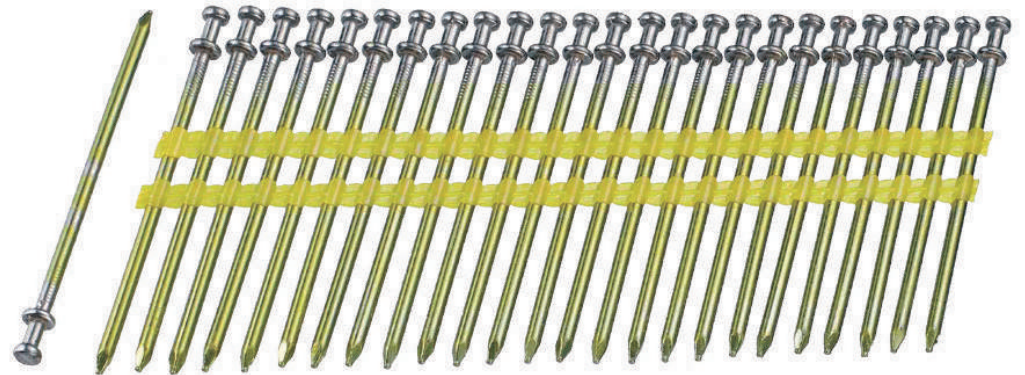
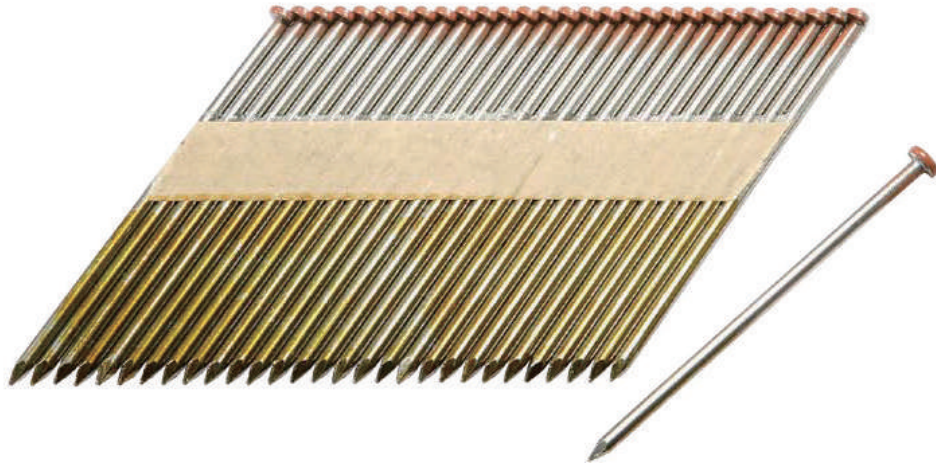
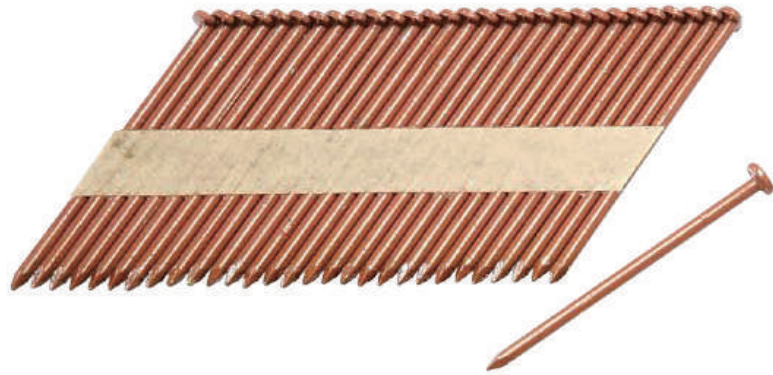

Colored Strip Nails

Double Head Plastic Strip Nails



# Strip Nails

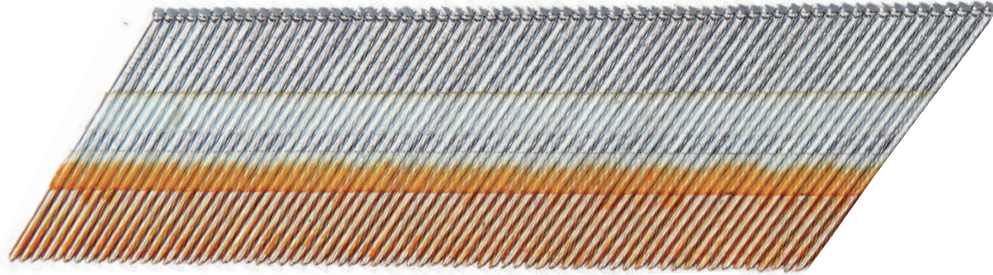

DA nails



Round Head Paper Strip Nails

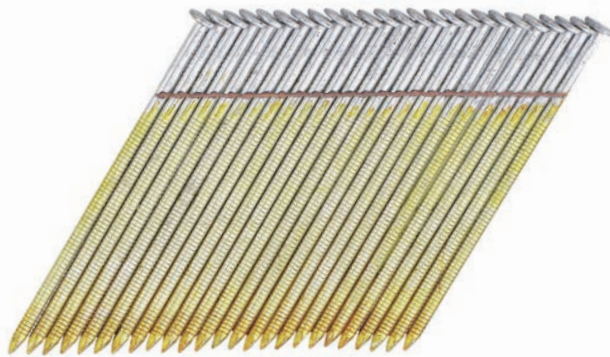

Single Wire Strip Nails



35° Anchoring Plastic Nails (Big Head)



## Strip Nails

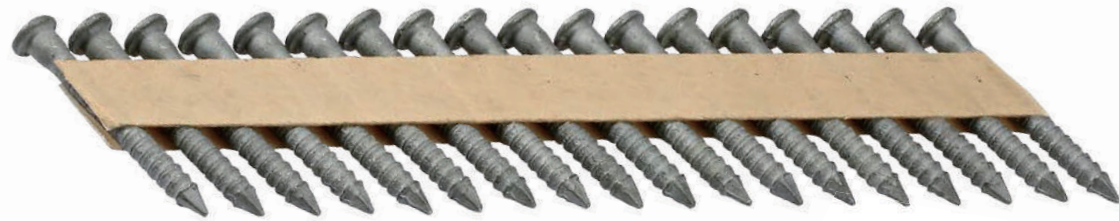

34° Positive placement nails /  
35° Anchoring paper collated strip nails big head

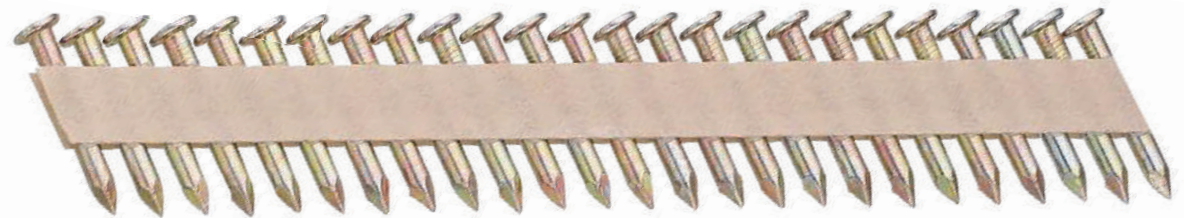

Metal Connecting Nails

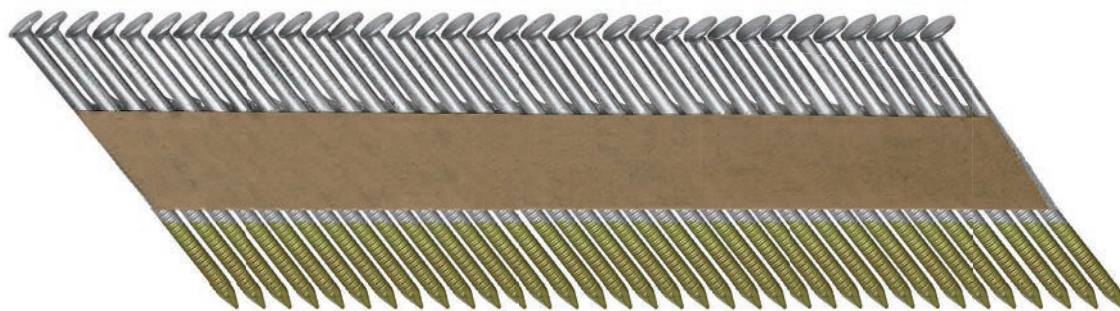

Paper Strip Nails



## Barbed Shank Strip Nails

Hot Dip Galv., Electrical Galv. And Bright Barbed shank strip nails

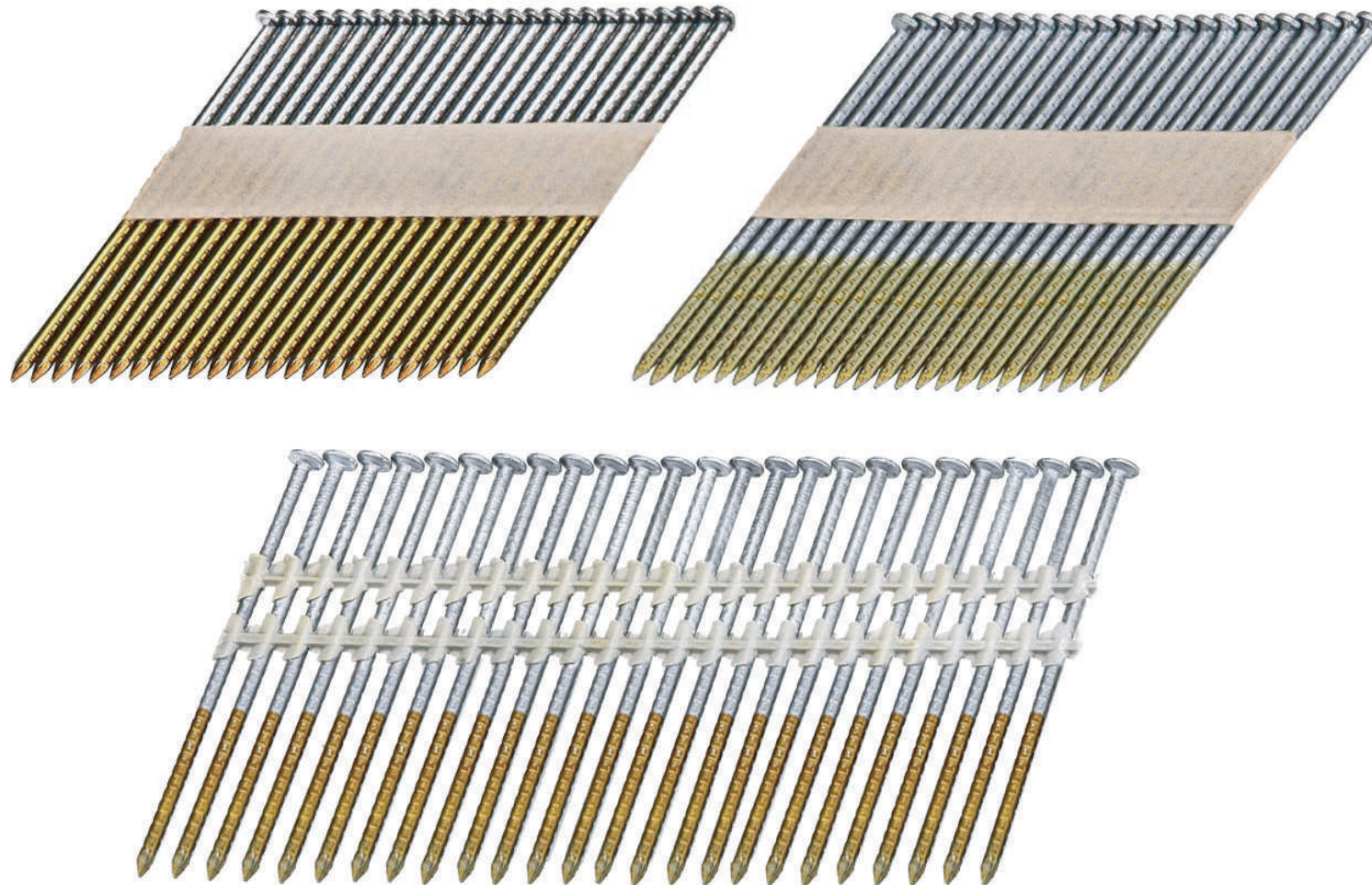

▪ Maximum thickness of Hot Dip Galv is 60u



## Special Coil Nails

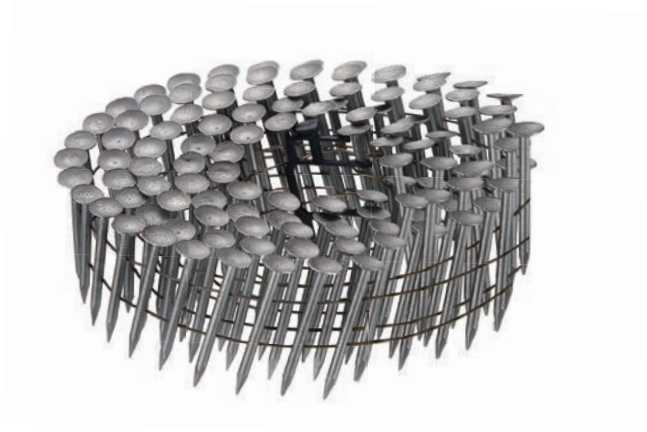

PC Drywall Coil Nail  
Shank Diameter  $\varnothing$ 2.5mm  
Length 38mm

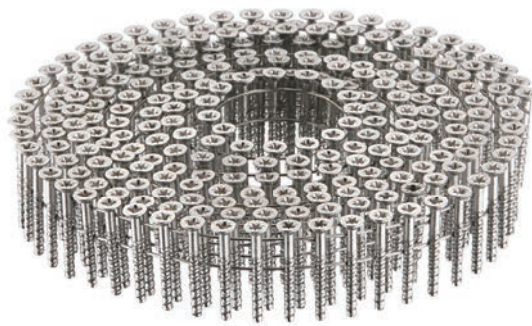

Coil Screw

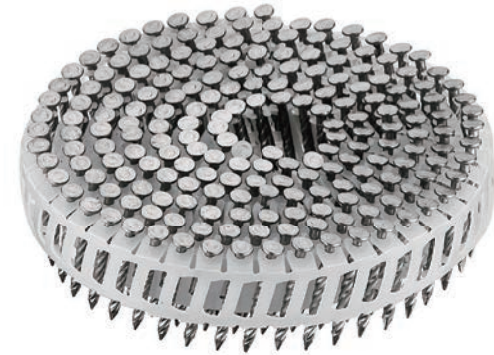

15° Hardened Plastic  
Screw Shank Coil Nails



15° Coil Nails With Hot Dip Galv  
( FAP Nails )

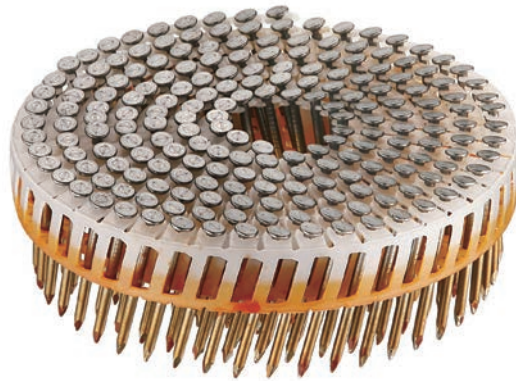

15° Plastic Sheet Coil Nails

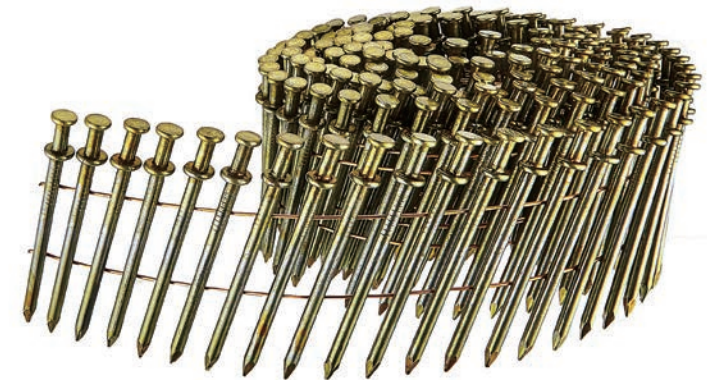

Duplex Head Coil Nails



Special Coil Nails

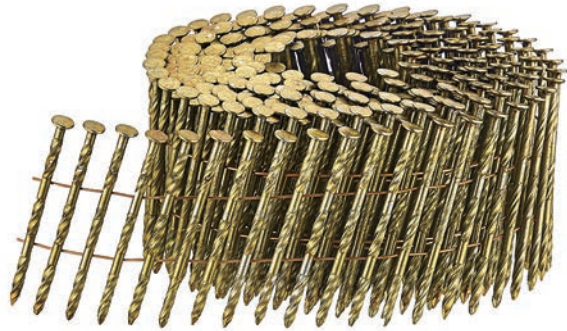

Screw Bright

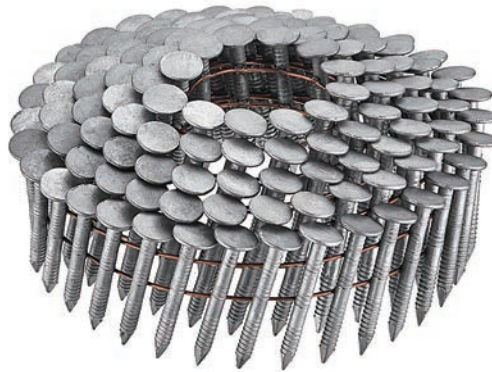

Screw Bright

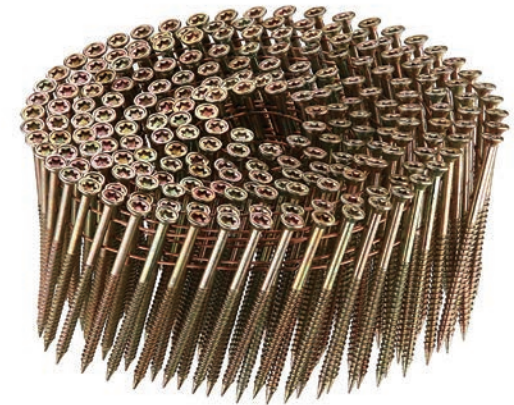

Hex Head, Torx recess Screws

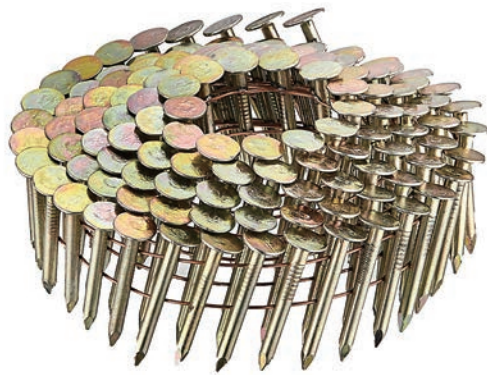

Roofing coil nail



Dome Head Ring

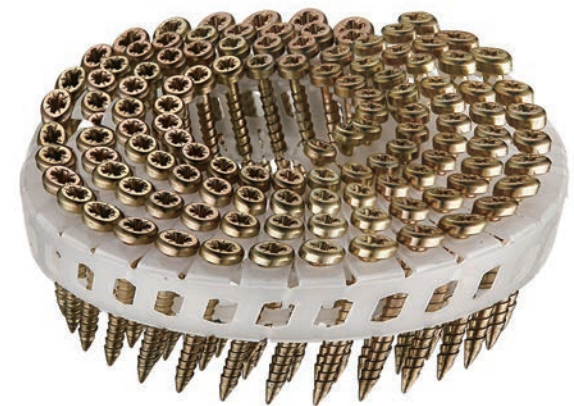

Ballistic Coil Nails (Scrail type)



## Corrugated Nails Comparison Chart

VIM'S MODEL NO.	SUITABLE NAILER
MCF124 SERIES	VIM MCF124
MCF120 SERIES	VIM MCF120
CF SERIES	<b>BeA</b> ® BA-T358, <b>SENCO</b> SC2, <b>Duo-Fast</b> ® CF-100A, <b>Haubold</b> ® WM15
X SERIES	VIM CF25S, <b>SENCO</b> ® SC2
W SERIES	VIM CF25S, <b>BeA</b> ® W15-358, W15-760
GC20 SERIES	VIM CF25P, <b>Paslode</b> ® MA-C20, PCF1000
WM SERIES	VIM CF185, <b>BeA</b> ® WM12-156
R SERIES	<b>Brevetti</b> ®, <b>ITW AMP</b> ®
WN SERIES	<b>Haubold</b> ® WN18XI, WN25XII <b>Predena</b> ® WN25SNS, BeA W25
GCN20 SERIES	<b>Paslode</b> ® MA-C20N

## Coil Type Corrugated Nails

### NR Series

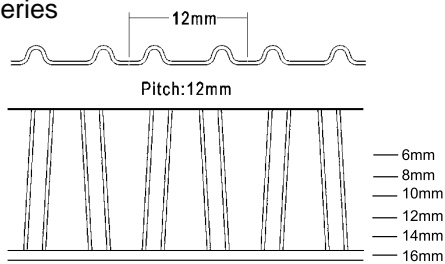

## Loose Corrugated Nails

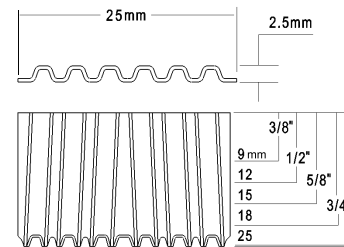
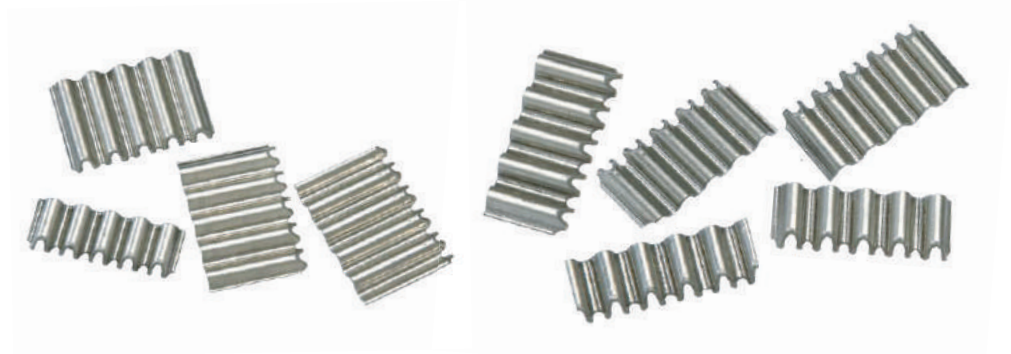

**ZB5 & WB5 Series**

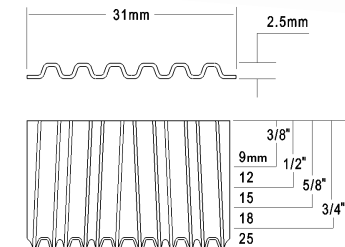

**6WB Series**

## Corrugated Nails

**Duo-Fast**®

**X Series** Corrugated Nails For VIM CF25S, **SENCO**® SC2, Crown: 25mm

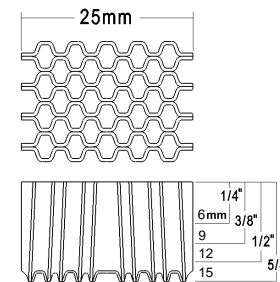



# Corrugated Nails

**WM Series** Corrugated Nails For VIM CF185, **BeA®** WM12-156  
Crown: 18.6mm

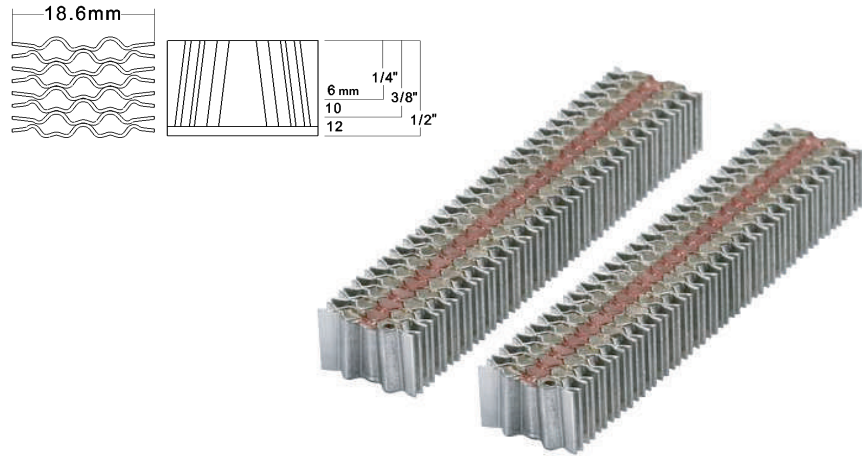

**MCF124 Series** Mini. Corrugated Nails For VIM MCF124  
Crown: 12.4mm

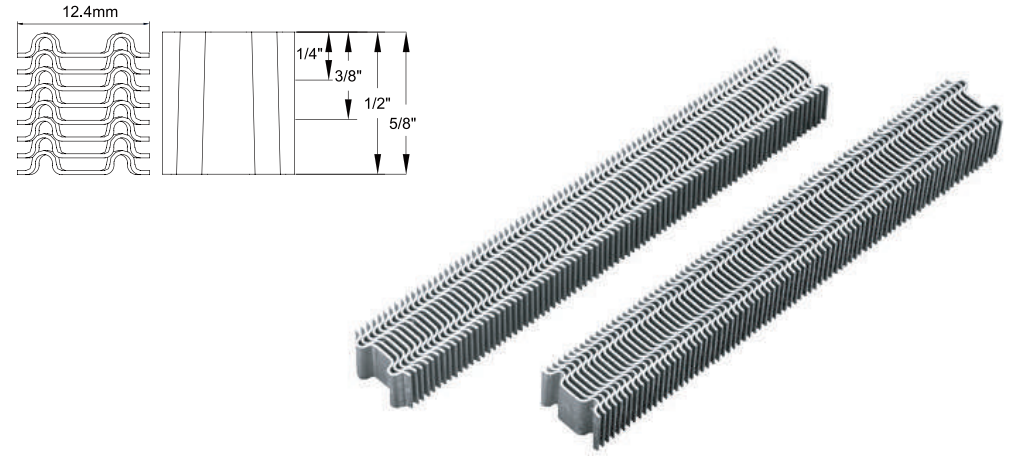

**W Series** Corrugated Nails For VIM CF25S, **BeA®** W15-358, W15-760,  
Crown: 25mm

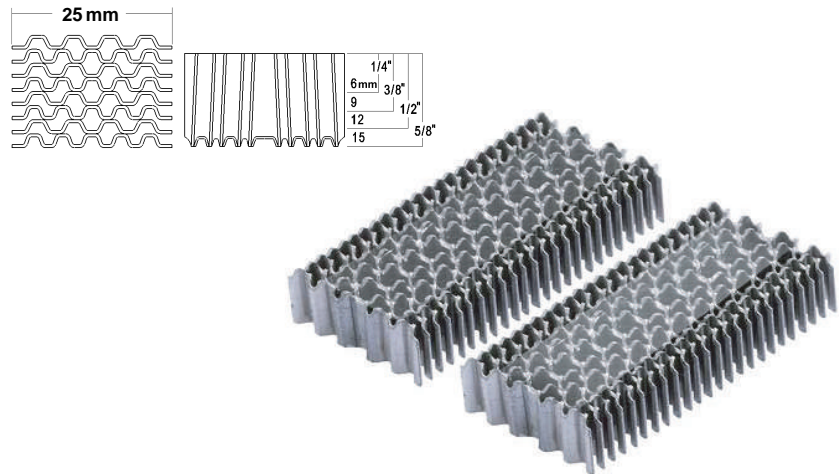

**WN Series** **u** mbo Corrugated Nails For **Haubold®** WN18XI, WN25XII,  
**Predena®** WN25SNS, **BeA®** W25  
Crown: 35mm

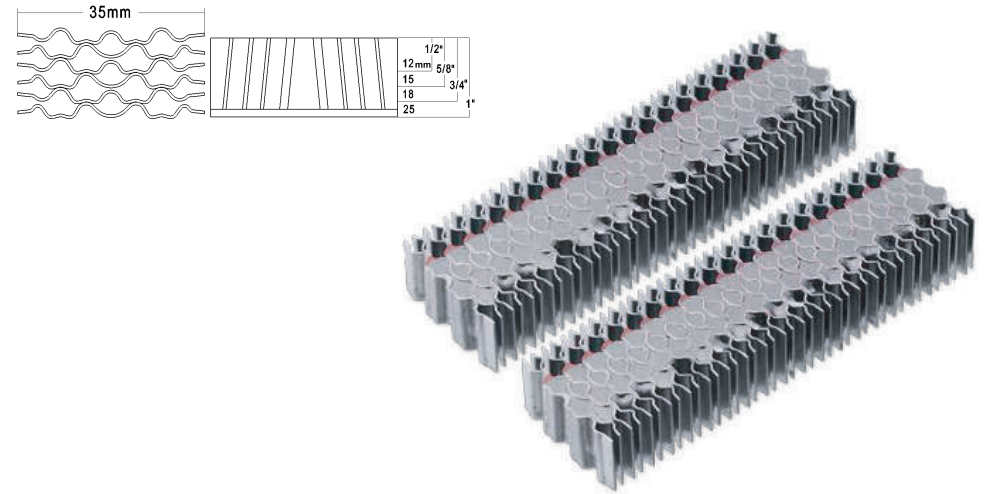

## Corrugated Nails

**CF Series** Corrugated Nails For **BeA®** BA-T358, **SENCO®** SC2, **Duo-Fast®** CF100A, **Haubold®** WM15  
Crown: 25mm

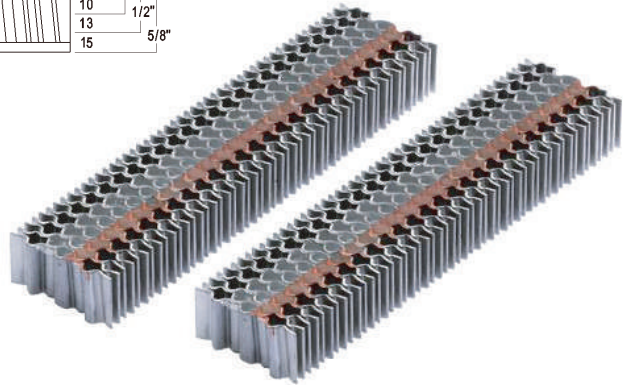
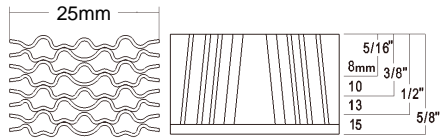

**MCF120 Series** Micro Corrugated Fasteners For VIM MCF120 Nailer  
Crown: 12.0mm

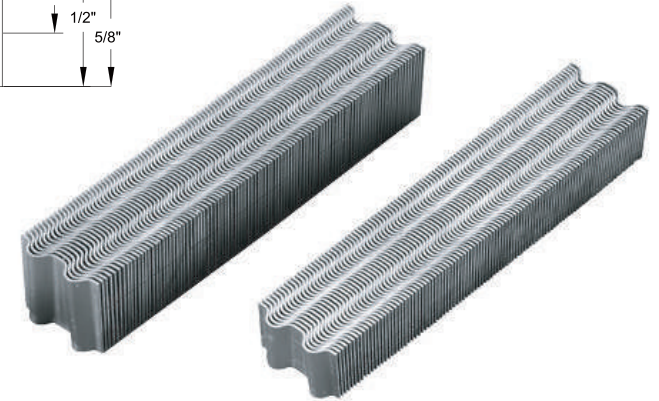
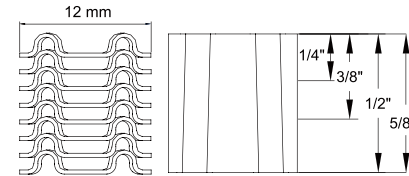

**GCN20 Series** Corrugated Nails For **Paslode®** MA-C20N  
Crown: 1/2"

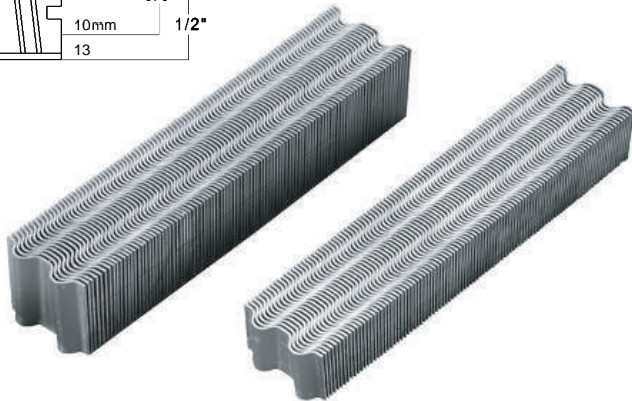
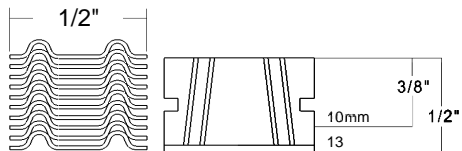

**GC20 Series** Corrugated Nails For VIM CF25P **Paslode®** MA-C20, PCF1000,  
Crown: 26.4 mm

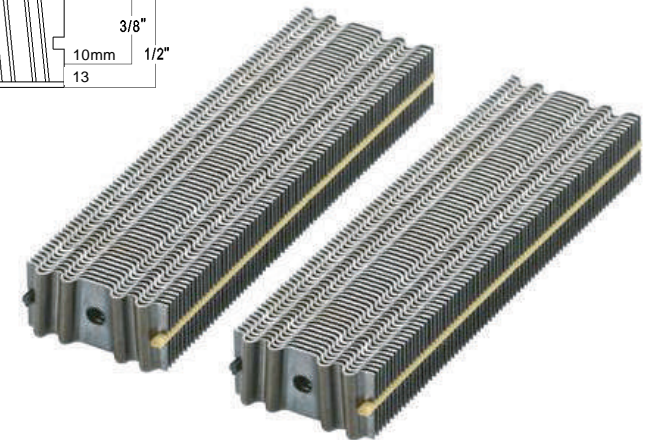
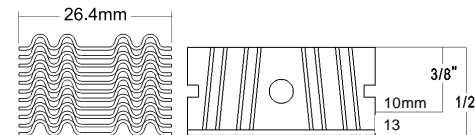

## Plastic Collated Concrete Nails



### PCS / PCK 0 DEG. STRAIGHT HEATED PLASTIC COLLATED CONCRETE NAILS

WITH STEPPED SMOOTH / KNURLING SHANK

- Nail Shank Dia.: 3.0 mm
- Nail Hed Dia.: 6.4 mm
- Length : 16,19,25,29,34,38, 40,45,50,55,60,65 mm



Smooth



Knurled



Ballistic  
Shank



Stepped  
Shank



### PDC PLASTIC COLLATED CONCRETE PINS WITH YELLOW OR WHITE ZINC COATING FOR GAS NAILER

WITH SMOOTH SHANK

- Nail Shank Dia.: 2.6 mm
- Nail Hed Dia.: 6.3 mm
- Length : 13,16,19,25,32,38,40 mm



### PDC PLASTIC COLLATED CONCRETE PINS WITH BLACK COATING FOR GAS NAILER

WITH SMOOTH SHANK

- Nail Shank Dia.: 2.6 mm
- Nail Hed Dia.: 6.3 mm
- Length : 13,16,19,25,32,38,40 mm



### DNC Nails (For P.A.T Tools)

- Shank Dia: 3.7mm
- Length: 27,29,32,42,52 mm



## 12 - 23 GA. Staples and Special Staples



U Staples



Power Crown Staples



Divergent Point Staples

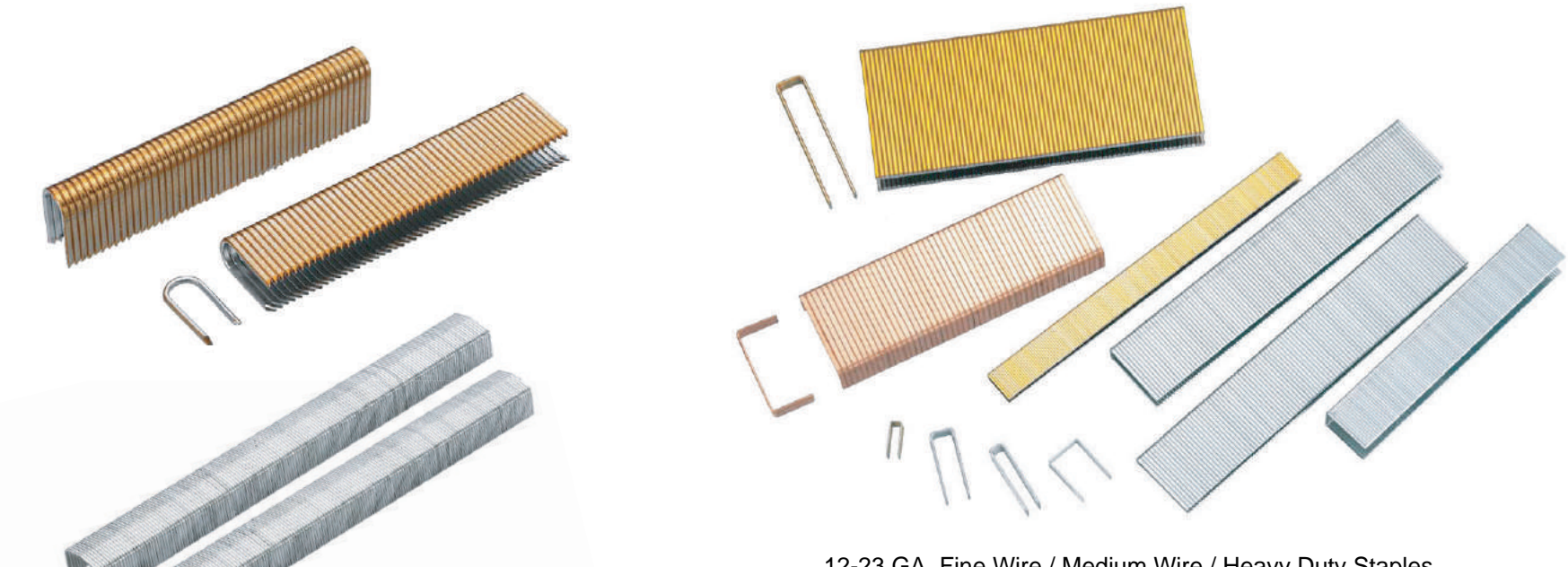

12-23 GA. Fine Wire / Medium Wire / Heavy Duty Staples

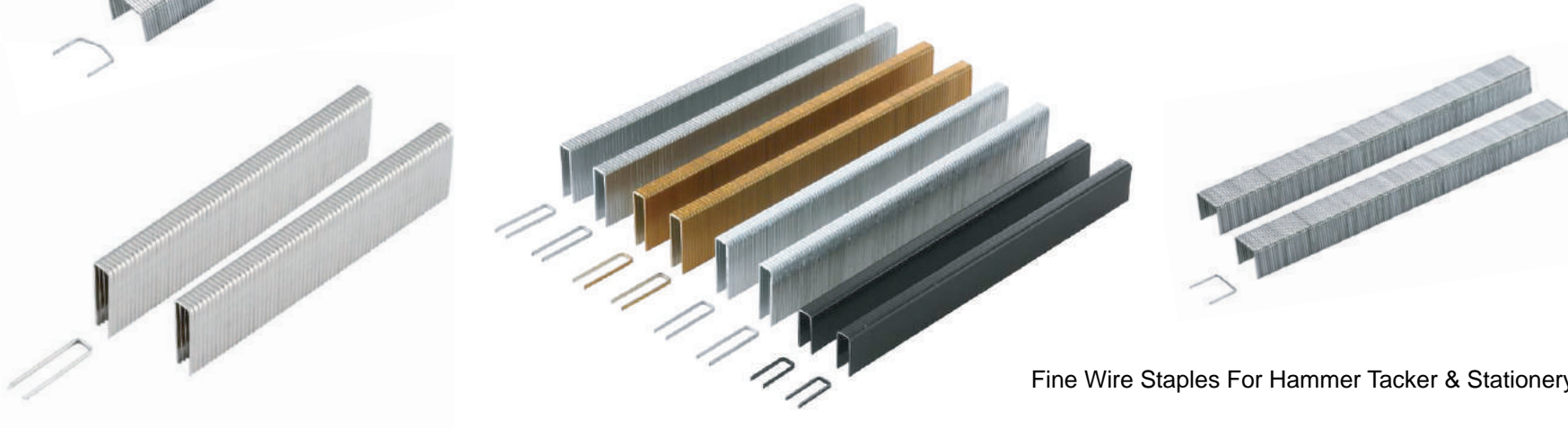

Fine Wire Staples For Hammer Tacker & Stationery

Staples With Different Color Coating



## Cable Staples

Model No: 1304C, 1306C

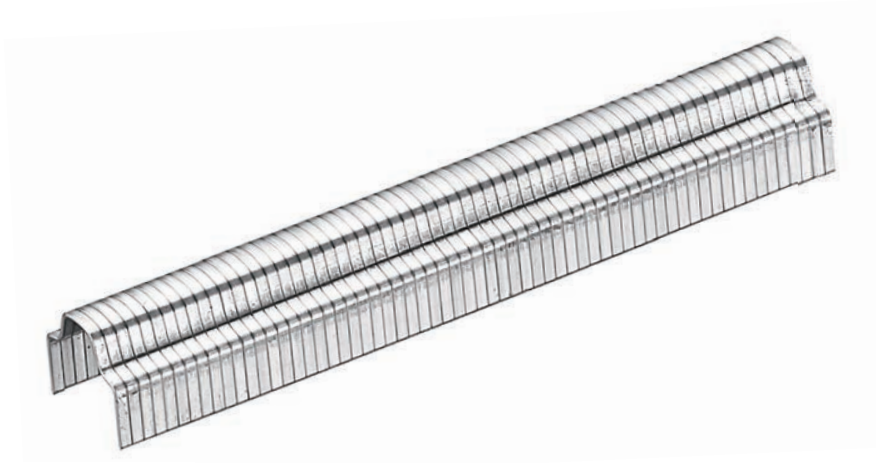

## Aluminum Staples

Model No: 711, 713, 506

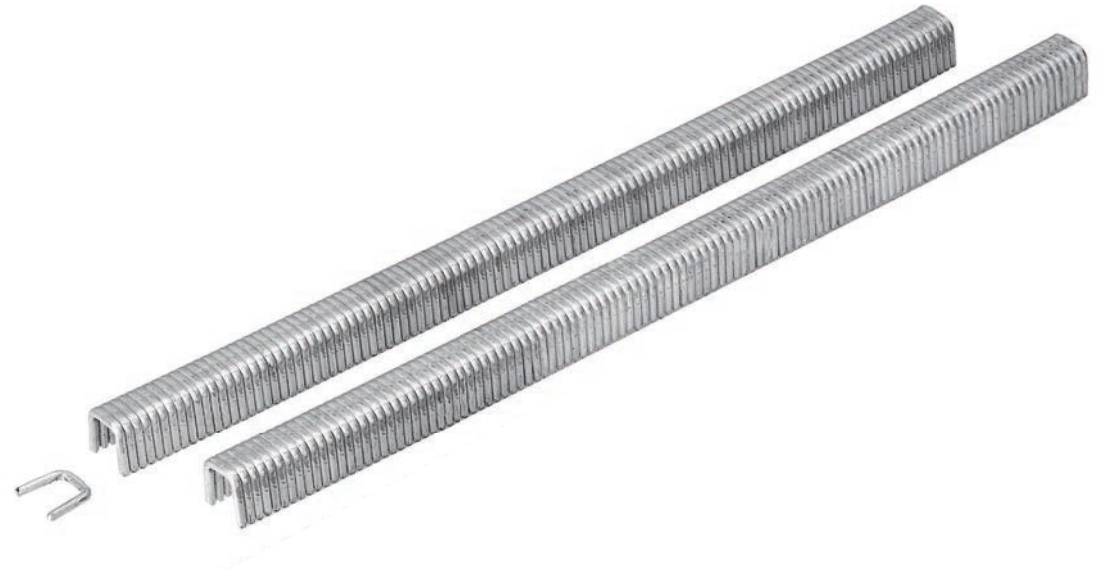

For Max Packner HR-PSII Hermetic Bag Sealer

Model No	1304C	1306C
Thickness(A)	1.25 mm	
Crown(B)	12.85 mm	
Width(C)	0.54 mm	
Length	4 mm	6 mm

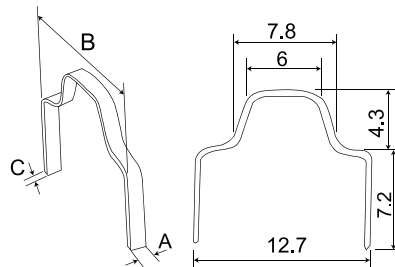

Model No	711	713	506
Crown(A)	7 mm	7 mm	8 mm
Length(B)	11 mm	13 mm	12 mm

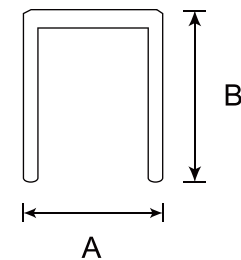

## Carton Closing

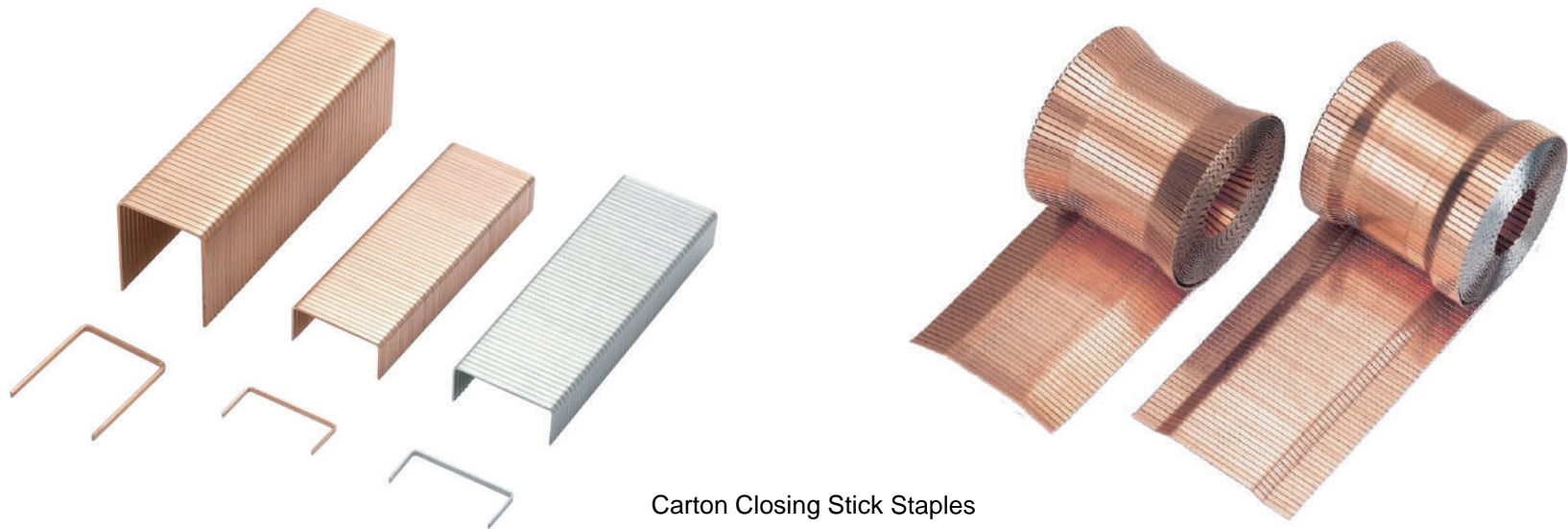

Carton Closing Stick Staples



Carton Closing Roll Staples



# Cartridge Wedges / V Nails / Frame Wedges

Cartridge Wedges - Soft / Hard Type : 5,7,10,12,15 mm

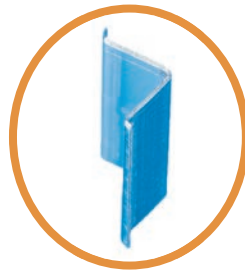
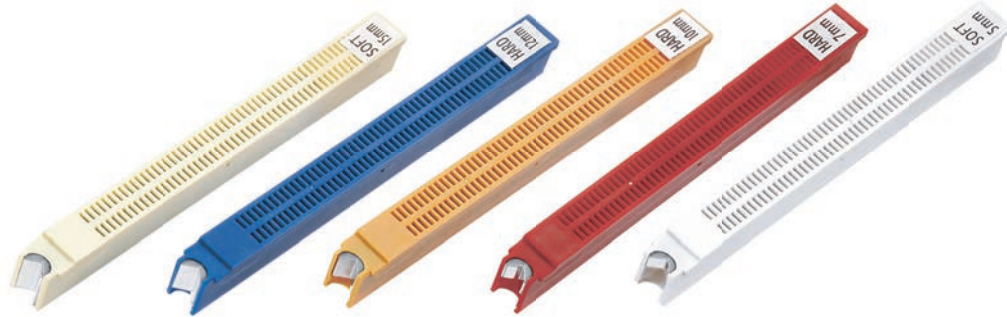

Hard V Nails & Soft V Nails-AL / UNI TYPE

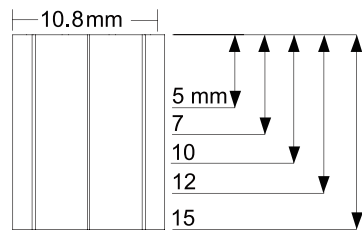
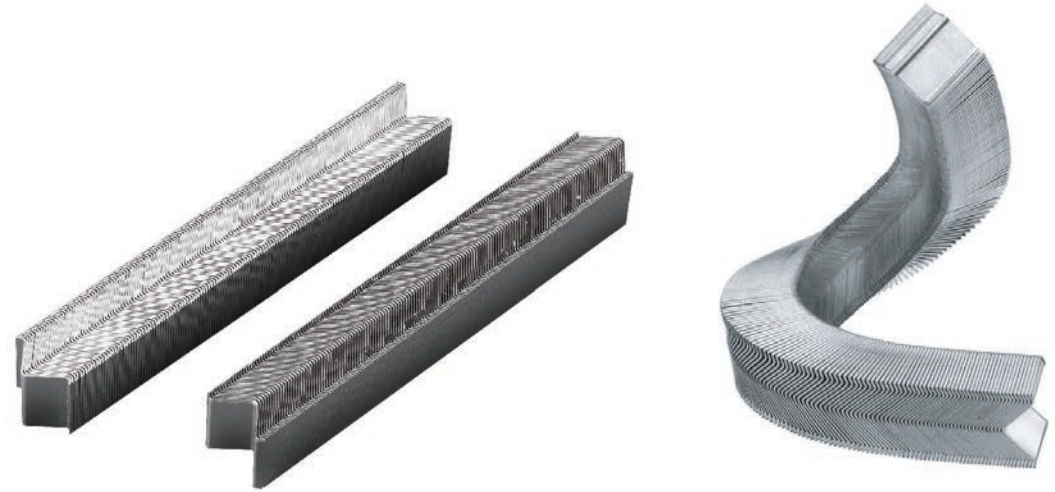

ALFA

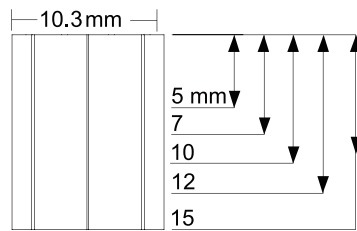

CASSESE

Flexipoints & Rigidpoints



Arrow Head Tab - Fletscher type

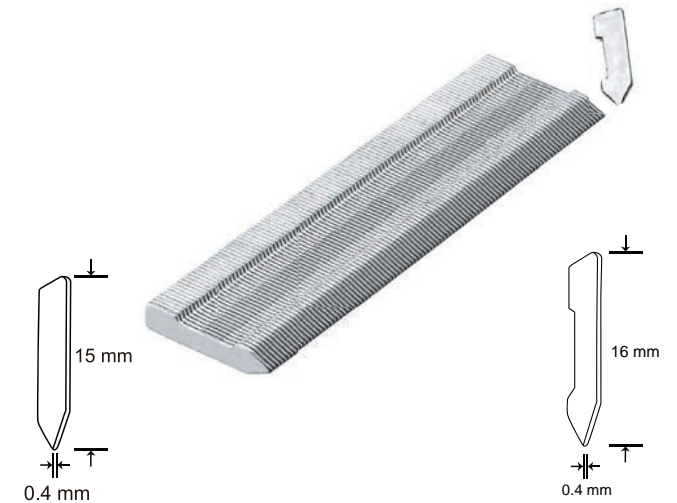

# Clinching Clips

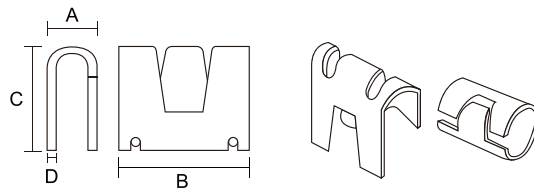
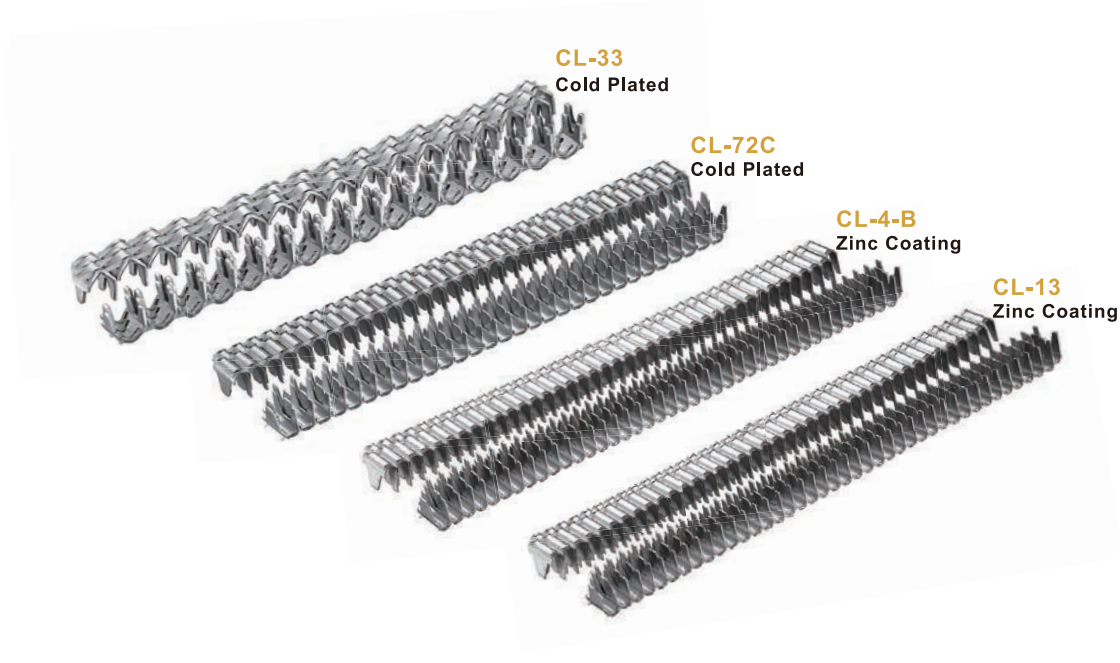

M66	Model	Crown(A)	Width(B)	Height ( C)	Thickness(D)
	CL-71A	6.2mm	18.5/17.5mm	13.2mm	0.78mm
	CL-71B	6.2mm	18.5/17.5mm	13.2mm	0.68mm
	CL-71C	6.2mm	18.5/17.5mm	13.2mm	0.60mm
	CL-72A	6.2mm	18.5/17.5mm	14.5mm	0.78mm
	CL-72B	6.2mm	18.5/17.5mm	14.5mm	0.68mm
	CL-72C	6.2mm	18.5/17.5mm	14.5mm	0.60mm
	CL-3A	6.2mm	21.8mm	14.5mm	0.78mm
	CL-3B	6.2mm	21.8mm	14.5mm	0.68mm
	CL-3C	6.2mm	21.8mm	14.5mm	0.60mm
	CL-4A	6.2mm	21.8mm	17.2mm	0.78mm
	CL-4B	6.2mm	21.8mm	17.2mm	0.68mm
	CL-4C	6.2mm	21.8mm	17.2mm	0.60mm
CL-24	7.8mm	21.8mm	12.5mm	0.78mm	

M45	Model	Crown(A)	Width(B)	Height ( C)	Thickness(D)
	CL-13	5mm	11mm	11.0mm	0.82mm
	CL-14	5mm	11mm	12.7mm	0.82mm
	CL-15	5mm	11mm	13.2mm	0.82mm

M46	Model	Crown(A)	Width(B)	Height ( C)	Thickness(D)
	CL-18	6.2mm	11mm	15mm	0.82mm
	CL-16	6.2mm	11mm	14mm	0.82mm
	CL-14	5.6mm	11mm	13mm	0.82mm
	CL-13	6.2mm	11mm	12mm	0.82mm
CL-33	10mm	11mm	13mm	1.50mm	

M65	Model	Crown(A)	Width(B)	Height ( C)	Thickness(D)
	CL-73	5mm	18.5mm	13.0mm	0.75mm
	CL-74	5mm	18.5mm	15.5mm	0.75mm
	CL-70	5mm	17.8mm	11.5mm	0.75mm
	CL-23	5mm	22.0mm	12.2mm	0.75mm
CL-24	5mm	22.0mm	13.0mm	0.75mm	

M85	Model	Crown(A)	Width(B)	Height ( C)	Thickness(D)
	CL-34	6.2mm	22.0mm	17.2mm	0.83mm
	CL-76	7.0mm	18.5mm	18.5mm	0.83mm
CL-88	8.5mm	21.8mm	20.5mm	0.80mm	





# Coil Clinching Clips



CL-16C

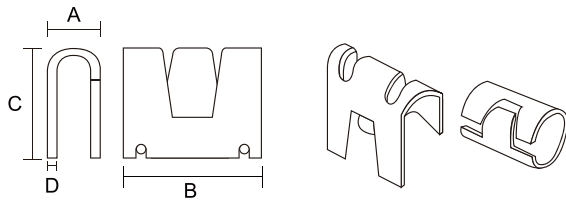

	Model	Crown(A)	Width(B)	Height ( C)	Thickness(D)
M66	CL-71AC	6.2mm	18.5/17.5mm	13.2mm	0.78mm
	CL-71BC	6.2mm	18.5/17.5mm	13.2mm	0.68mm
	CL-71CC	6.2mm	18.5/17.5mm	13.2mm	0.60mm
	CL-72AC	6.2mm	18.5/17.5mm	14.5mm	0.78mm
	CL-72BC	6.2mm	18.5/17.5mm	14.5mm	0.68mm
	CL-72CC	6.2mm	18.5/17.5mm	14.5mm	0.60mm
	CL-3AC	6.2mm	21.8mm	14.5mm	0.78mm
	CL-3BC	6.2mm	21.8mm	14.5mm	0.68mm
	CL-3CC	6.2mm	21.8mm	14.5mm	0.60mm
	CL-4AC	6.2mm	21.8mm	17.2mm	0.78mm
	CL-4BC	6.2mm	21.8mm	17.2mm	0.68mm
	CL-4CC	6.2mm	21.8mm	17.2mm	0.60mm
	CL-24C	7.8mm	21.8mm	12.5mm	0.78mm

	Model	Crown(A)	Width(B)	Height ( C)	Thickness(D)
M45	CL-13C	5mm	11mm	11.0mm	0.82mm
	CL-14C	5mm	11mm	12.7mm	0.82mm
	CL-15C	5mm	11mm	13.2mm	0.82mm

	Model	Crown(A)	Width(B)	Height ( C)	Thickness(D)
M46	CL-18C	6.2mm	11mm	15mm	0.82mm
	CL-16C	6.2mm	11mm	14mm	0.82mm
	CL-14C	5.6mm	11mm	13mm	0.82mm
	CL-13C	6.2mm	11mm	12mm	0.82mm
	CL-33C	10mm	11mm	13mm	1.50mm

	Model	Crown(A)	Width(B)	Height ( C)	Thickness(D)
M65	CL-73C	5mm	18.5mm	13.0mm	0.75mm
	CL-74C	5mm	18.5mm	15.5mm	0.75mm
	CL-70C	5mm	17.8mm	11.5mm	0.75mm
	CL-23C	5mm	22.0mm	12.2mm	0.75mm
	CL-24C	5mm	22.0mm	13.0mm	0.75mm

	Model	Crown(A)	Width(B)	Height ( C)	Thickness(D)
M85	CL-34C	6.2mm	22.0mm	17.2mm	0.83mm
	CL-76C	7.0mm	18.5mm	18.5mm	0.83mm
	CL-88C	8.5mm	21.8mm	20.5mm	0.80mm





**VIM INTERNATIONAL ENTERPRISE CO., LTD.**

*Our Guarantee:*  
*Lowest MOQ.*  
*Stock always available.*  
*Fastest delivery.*  
*Quality satisfaction.*  
*Longest life time and durable quality.*





**VIM INTERNATIONAL ENTERPRISE CO., LTD.**

No. 21, Sec. 1, Liouchuan E. Rd., South District,  
Taichung City 402, Taiwan R.O.C.

Tel: 886-4-2373-0103 / Fax: 886-4-2373-0207

E-mail: [vimcom@ms48.hinet.net](mailto:vimcom@ms48.hinet.net)

Web: [www.evim.com.tw](http://www.evim.com.tw) / [www.vim.com.tw](http://www.vim.com.tw)

